

Product Information Packet

November 8, 2016

Data shown is for the current revision model #. Ensure your nameplate model # matches.

Model Number:	5KS215SAA104D3
Catalog Number:	M9733
Instruction Manual:	GEI-56128
Connection Diagram:	GEM2034E-FIG1
Outline Drawing:	4002B5821PAP5201

Accessory Connection Diagrams			
Bearing Thermocouple:	None	Heater:	None
RTD:	None	Thermistor:	None
Thermostat:	None	Winding Thermocouple:	None
Bearing RTD:	None		

Table of Contents

Specification	01
Performance Characteristics	02
Outline Drawing	03
Connection Drawing(s)	04
Spare parts	05



Marks:

MODEL NUMBER:	5KS215SAA104D3	Estimated Weight:	220 Lbs
Outline Drawing:	4002B5821PAP5201	Time Rating:	CONT
Connection Diagram:	GEM2034E-FIG1	Enclosure:	TEFC
Instruction Book:	GEI-56128	Encl Construction:	X\$D
Design Code:	21BD0121B	Ambient Max(°C):	40
Type:	KS	Alt Ambient Max(°C):	65
Frame:	215T	Insulation Class:	H
Phases:	3	NEMA Design:	B
Poles:	2	Nominal Efficiency:	90.2 %
Output Power:	10HP 7.4KW	Guaranteed Efficiency:	89.5
RPM:	3520	3/4 Load Efficiency:	91.0
Voltage:	575	KVA Code:	H
Hertz:	60	Max KVAR:	2.2
Amps - FL:	9.2	Power Factor:	90.0
Service Factor:	1.15	Bearing - DE:	6208ZC3
Alt Service Factor:	1.00	Bearing - ODE:	6208ZC3

Enclosure is Totally Enclosed Fan-Cooled

Stamped Nameplate Notes:

STAMP NP249A5564P051 AS BELOW:
 MODEL:5KS215SAA104D3 S/N: XXX
 CSA CERTIFIED CSA09.2216219 FOR EX NA IIC 200C GC
 CL 1 ZONE2 AEX NA IIC 200C;CL 1 DIV2 GRP ABCD 200C
 IN -40C <= AMB <= 40C, 1.0 SF ON SINE-WAVE PWR
 SURF TEMP 230C AT 1.15SF ON SINE-WAVE PWR
 OR 200C VT OR 215C CT OR 200C CHP PWM CONTROL
 ALTERNATE RATING FOR PWM CONTROL 1.0SF 40C AMB
 VT 0 - 60 HZ, CT 8.6-60 HZ, CHP 60-90 HZ.

Additional Information:

2P - T EXTN
 STANDARD FLOOR MOUNT
 C/BOX 55 CU IN-1.00 NPT
 F1 CONDUIT BOX MOUNTING
 OIL RESISTANT SLEEVING ON LEADS

Performance Characteristics

1st Winding 1st Connection

Design: 21BD0121B

Marks:

LOAD %	125.0	115.0	100.0	75.0	50.0	25.0	0.0
% EFF	88.58	89.25	90.29	91.02	90.9	87.39	0.00
% PF	90.02	90.09	89.84	88.02	82.39	64.47	9.22
AMPS	11.74	10.71	9.22	7.01	5	3.32	2.41

TORQ(FL)#FT	14.92	TORQ(LR)%FL	200.92	TORQ(BD)%FL	278.35
AMPS(LR)	58.47	PF AT START	0.36		

This motor is capable of two cold or one hot start with a maximum connected load inertia of 75 Lb-Ft Sq (3.16 Kg-meter Sq) at 100% voltage, where the load torque varies with the square of the speed. Acceleration time with maximum inertia and the above load type is 35 seconds. Safe stall time at 100% voltage is 67 seconds cold, 42 seconds hot. Rotor inertia is 0.39 Lb-Ft Sq (0.02 Kg-meter Sq).

Open Circuit A-C:	0.47	Short Circuit D-C:	0.01
Short Circuit A-C:	0.017	X/R Ratio:	3.875
Stator Slots:	36	Rotor Slots:	26

Speed Torque Current Curve (First Connection, First Speed)

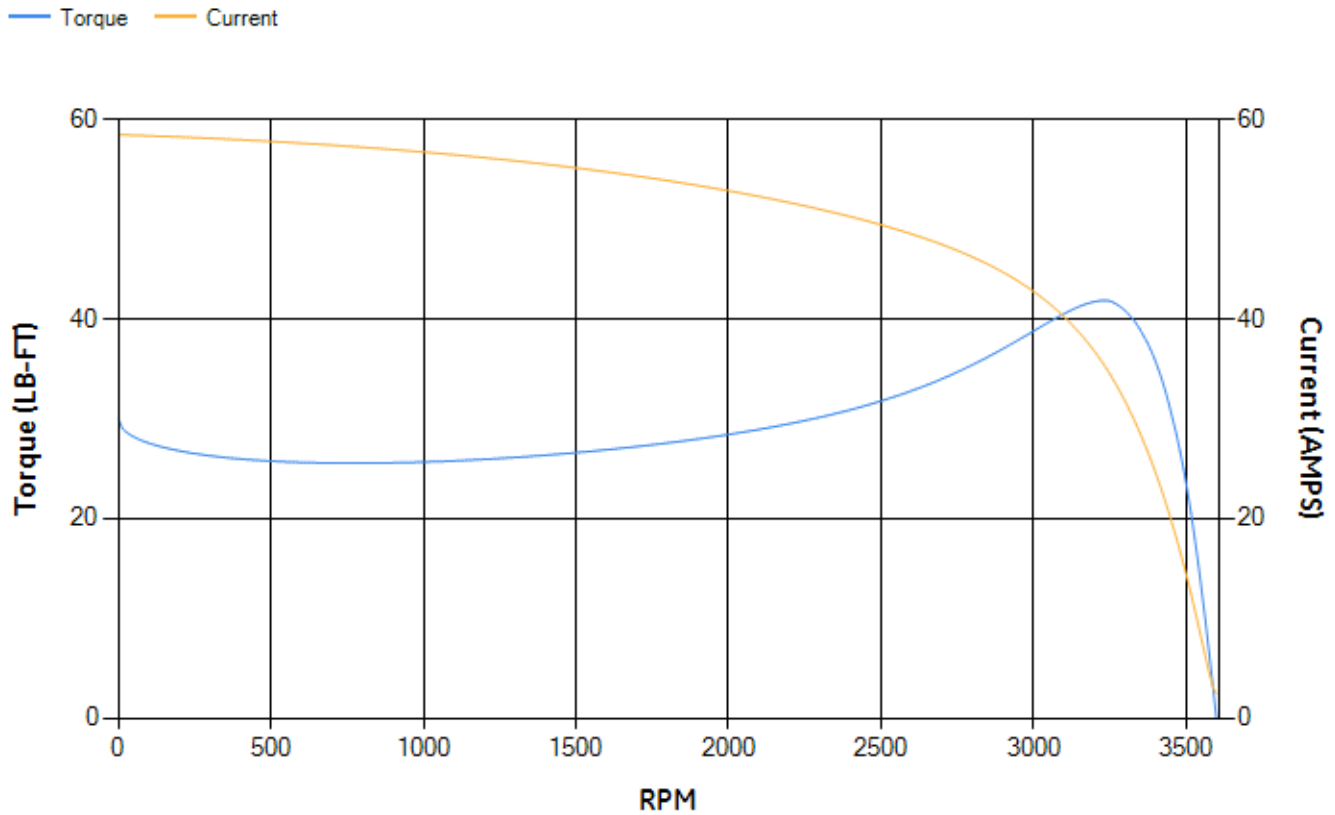

Marks:

NOTE 1: CONDUIT BOX MAY BE ASSEMBLED WITH ENTRANCE UP, DOWN OR TO EITHER SIDE.
 NOTE 2: F1 ASSEMBLY AS SHOWN. F2 ASSEMBLY CONDUIT BOX ON OPPOSITE SIDE FROM SHOWN LOCATION.

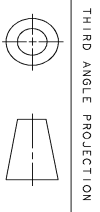
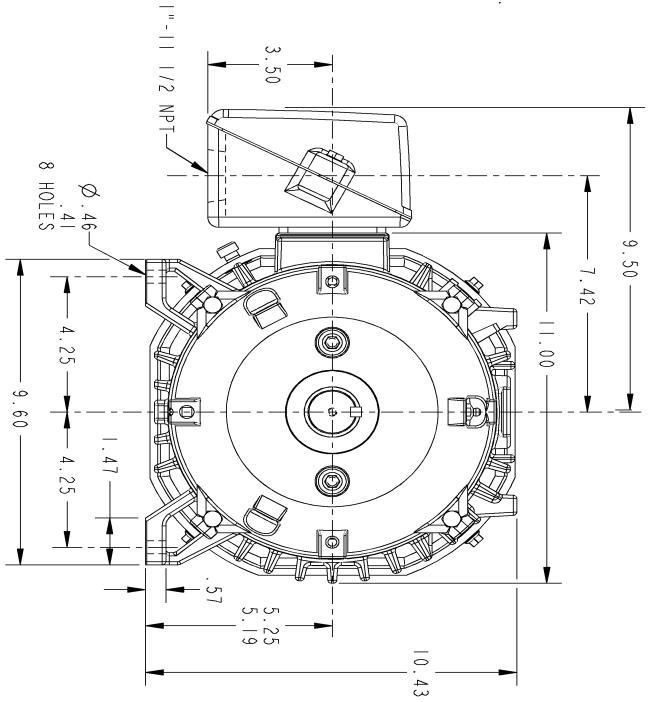
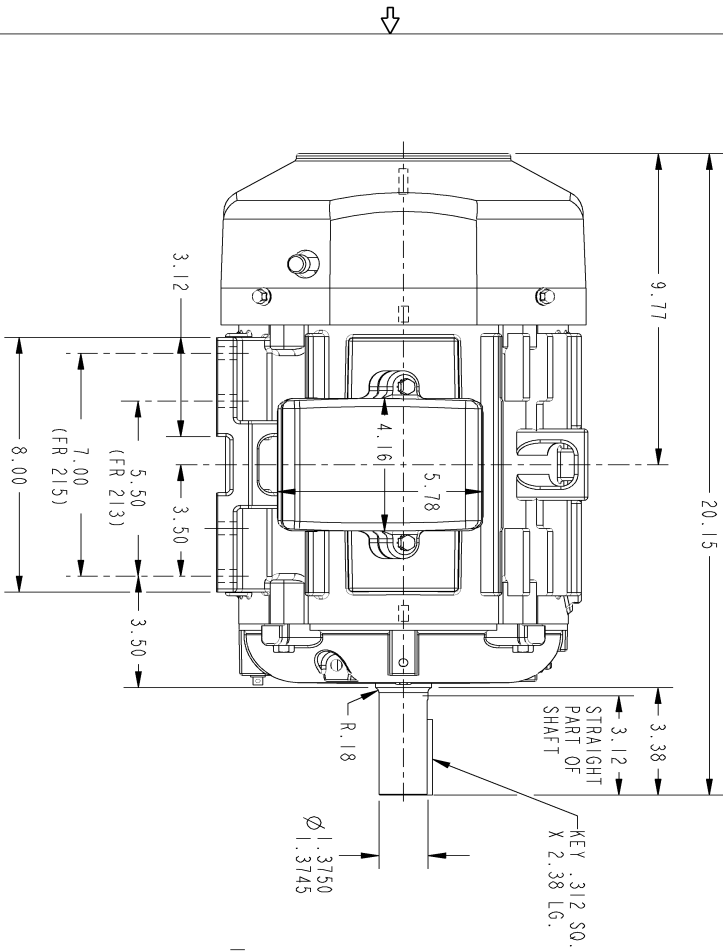

THIRD ANGLE PROJECTION

SIZE B DRAWING NO. 4002B5821PAP5201

SH 1 REV 1

REVISIONS			
REV.	DESCRIPTION	DATE	APPROVED
1	ISAC #15-0018	08/01/2015	ADI

SIGNATURES	DATE	GE Industrial Systems GENERAL ELECTRIC COMPANY Fort Wayne, Indiana
DRAM	JAN 22/02	
CHECKED	FEB 08/02	
ENGR		
ISSUED	APR 03/02	
APPLIED PRACTICES		
SIZE DRAWING	SCALE: 0.300	REF. NO: 4002B5821PAP201
4002B5821PAP5201		
REV. 1		

DISTRIBUTION: PMP-1BK15

Marks:

Connection Diagram
GEM2034E-FIG1



End shield Assembly		
Part Description	DE Side Part#	ODE Side Part#
End Shield	4004D5282PB1	4004D5282SJ1
Bearing	235A2603AA01	235A2603AA01
Slinger/Inproseal	149C4399G01	149C4399G01

Fan & Fan Cover Assembly	
Part Description	Part#
Fan	159C6704G01
Fan Cover	4003C5787PA1

Conduit & Accessories Box Assembly	
Part Description	Part#
Conduit Box	4002B5721PA-G01

Mechanical Accessories	
Part Description	Part#
Brake	
Tachometer	