

TYPE	OUTPUT		POLE	TIME RATING	VOLTAGE V	Hz	SYN.SPEED R.P.M
	HP.	kW.					
AEHGK	100	74.6	6	CONT.	2300/4160	60	1200

TOTALLY ENCLOSED FAN-COOLED TYPE. SQUIRREL-CAGE ROTOR

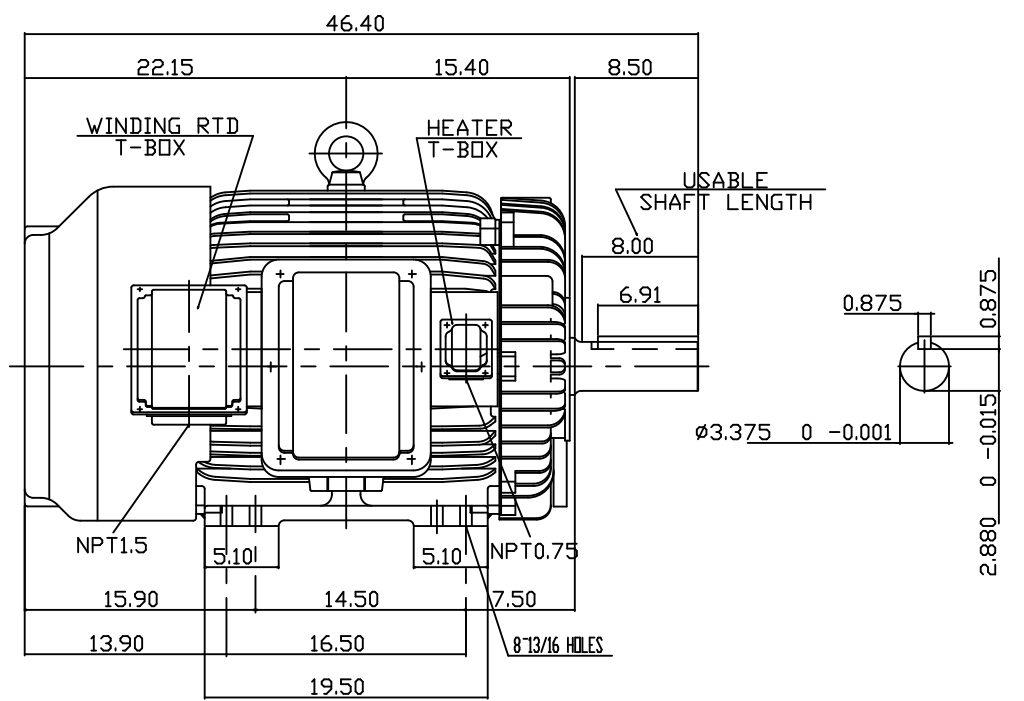
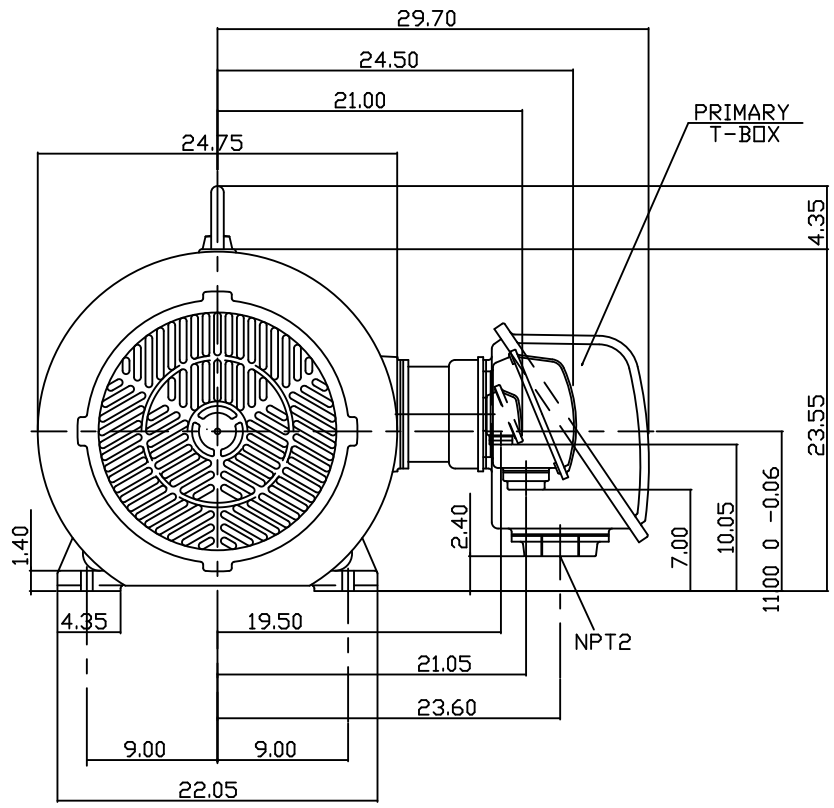

- NOTE:
1. DIMENSIONS IN INCH
  2. FRAME NO. 445T
  3. F CLASS INSULATION, S.F.1.15
  4. FOR DIRECT FLEXIBLE COUPLING
  5. WITH WINDING RTD & SPACE HEATER
  6. ENCLOSURE: IP54
  7. BEARING SIZE DRIVE END: 6318  
NON-DRIVE END: 6316
  8. APPROX. WEIGHT: 2080 LBS

TW-56C

DATE: 09-20-2013	OUTLINE DIMENSIONS
CATALOG # KG1006R	3-PHASE INDUCTION MOTOR

DWN. C. COOK	MAY 13, 2013

TEC Westinghouse

DWG NO. 3B040C097 REV: 00