

Product Information Packet

November 7, 2016

Data shown is for the current revision model #. Ensure your nameplate model # matches.

Model Number:	5KS405CAG308C
Catalog Number:	E9299
Instruction Manual:	GEI-56128
Connection Diagram:	GEM2034E-FIG7
Outline Drawing:	225B5700AT

Accessory Connection Diagrams			
Bearing Thermocouple:	None	Heater:	None
RTD:	None	Thermistor:	None
Thermostat:	None	Winding Thermocouple:	None
Bearing RTD:	None		

Table of Contents

Specification	01
Performance Characteristics	02
Outline Drawing	03
Connection Drawing(s)	04
Spare parts	05



Marks:

MODEL NUMBER:	5KS405CAG308C	Estimated Weight:	1570 Lbs
Outline Drawing:	225B5700AT	Time Rating:	CONT
Connection Diagram:	GEM2034E-FIG7	Enclosure:	TEFC
Instruction Book:	GEI-56128	Encl Construction:	XP
Design Code:	40ED3036A	Ambient Max(°C):	40
Type:	KS	Alt Ambient Max(°C):	XX
Frame:	405T	Insulation Class:	F
Phases:	3	NEMA Design:	A
Poles:	6	Nominal Efficiency:	94.5 %
Output Power:	75HP 55.5KW	Guaranteed Efficiency:	93.6
RPM:	1190	3/4 Load Efficiency:	95.0
Voltage:	460	KVA Code:	H
Hertz:	60	Max KVAR:	18.2
Amps - FL:	85.4	Power Factor:	87.0
Service Factor:	1.0	Bearing - DE:	6316ZC3
Alt Service Factor:	XX	Bearing - ODE:	6316ZC3

Enclosure is Totally Enclosed Fan-Cooled

Stamped Nameplate Notes:

EXPLOSION PROOF MOTOR
TEMP CODE T3C
THERMOSTAT LEADS TB1-TB2:TRIP

Additional Information:

STAMP NP235A3573 AS FOLLOWS:
CL I GR C&D CL II GR F&G
6 POLE, T SHAFT EXTN
EXPLOSION PROOF
(3)NC THERMOSTAT LEADS TO MAIN CONDUIT BOX
920 Cu. In. CBOX

Performance Characteristics

1st Winding 1st Connection

Design: 40ED3036A

Marks:

LOAD %	125.0	115.0	100.0	75.0	50.0	25.0	0.0
% EFF	94.28	94.52	95.01	95.01	94.56	91.79	0.00
% PF	87.32	87.29	86.85	84.47	77.68	57.92	5.4
AMPS	106.58	97.84	85.07	65.6	47.78	33.01	25.36

TORQ(FL)#FT	330.86	TORQ(LR)%FL	225.55	TORQ(BD)%FL	257.75
AMPS(LR)	628.68	PF AT START	0.37		

This motor is capable of two cold or one hot start with a maximum connected load inertia of 5326 Lb-Ft Sq (224.22 Kg-meter Sq)at 100% voltage, where the load torque varies with the square of the speed. Acceleration time with maximum inertia and the above load type is 42 seconds. Safe stall time at 100% voltage is 92 seconds cold, 62 seconds hot. Rotor inertia is 54.27 Lb-Ft Sq (2.28 Kg-meter Sq).

Open Circuit A-C:	1.075	Short Circuit D-C:	0.02
Short Circuit A-C:	0.04	X/R Ratio:	7.59
Stator Slots:	72	Rotor Slots:	60

Speed Torque Current Curve (First Connection, First Speed)

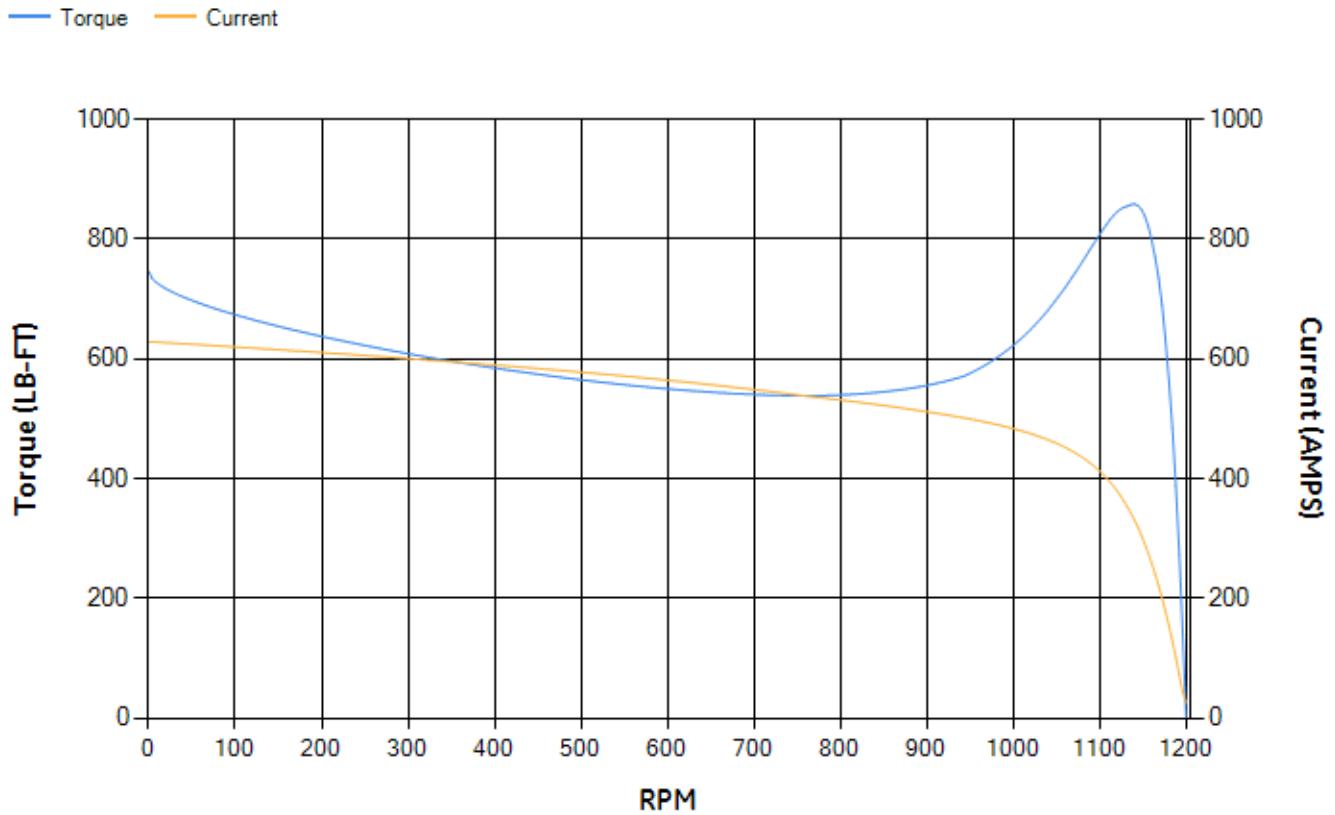

NAME: 90422 OBJECT: 225B5700AT DATE: 26-Jul-02 03:28:46

Marks:

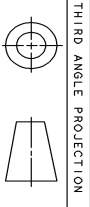
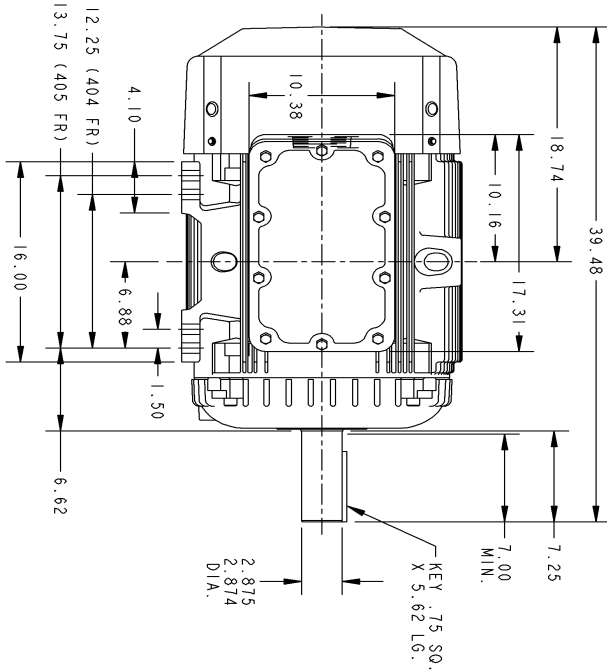
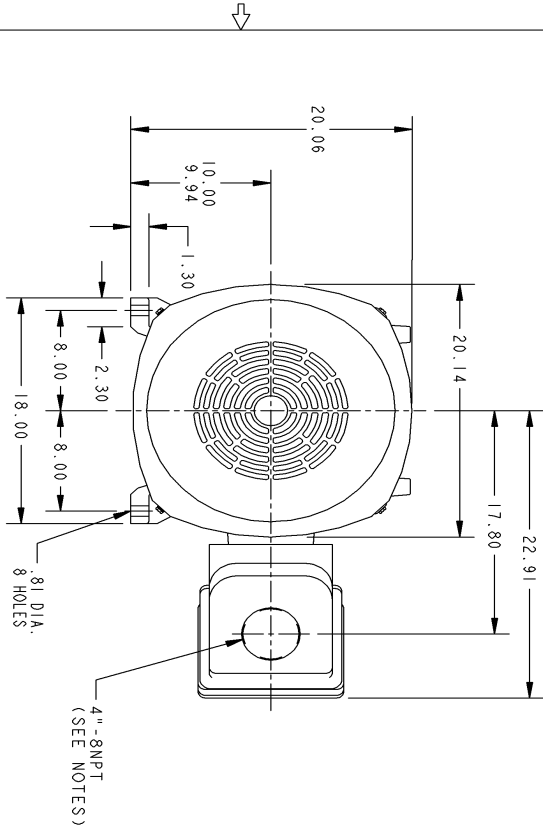

THIRD ANGLE PROJECTION

- NOTES:
1. CONDUIT BOX MAY BE PLACED WITH THE ENTRANCE ON EITHER SIDE OR UP.
 2. F-1 ASM AS SHOWN
 3. F-2 ASM-COND. BOX ON OPPOSITE SIDE.

GE PROPRIETARY INFORMATION
 This document is the property of General Electric Company ("GE") and contains confidential information of GE. This document is loaned to the recipient under the understanding that the information contained herein shall be disclosed only to those individuals who are authorized to receive it and shall be returned to GE upon request. This document shall be returned to GE upon its request. It is not to be used for any other purpose without the express written consent of GE. This document shall be returned to GE upon its request. It is not to be used for any other purpose without the express written consent of GE.

SIZE: 225B5700AT

REV.	DESCRIPTION	DATE	APPROVED

UNLESS OTHERWISE SPECIFIED:	SIGNATURES	DATE
DIMENSIONS ARE IN INCHES	DRWN	25-JUL-02
TOLERANCE ON:	CHECKED	25-JUL-02
2 PL. DECIMALS ± 0.01	ENGRS	
3 PL. DECIMALS ± 0.005	ISSUED	25-JUL-02
ANGLES ± 0.5	APPLIED PRACTICES	

404-405 "T" XP (920 CU. IN. BOX)
225B5700AT
 SCALE: DRAWING SCALE

GE Industrial Systems
GENERAL ELECTRIC COMPANY
 Fort Wayne, Indiana

OUTLINE

DISTRIBUTION:

Marks:

Connection Diagram
GEM2034E-FIG7

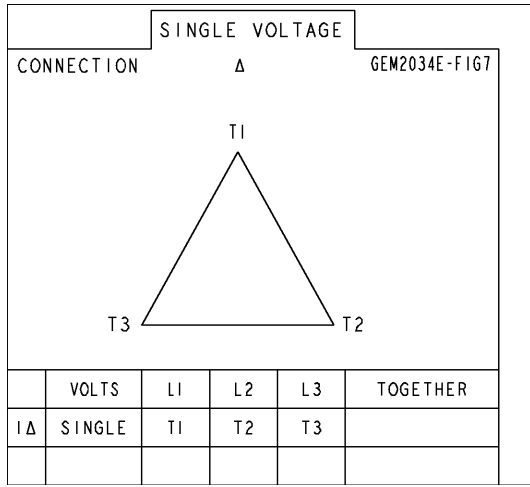

End shield Assembly		
Part Description	DE Side Part#	ODE Side Part#
End Shield	128D6582CA1	128D6582CB1
Bearing	235A2518AC01	235A2518AC01
Slinger/Inproseal		

Fan & Fan Cover Assembly	
Part Description	Part#
Fan	159C7100G02
Fan Cover	40FC6550G001

Conduit & Accessories Box Assembly	
Part Description	Part#
Conduit Box	179B9027G01

Mechanical Accessories	
Part Description	Part#
Brake	
Tachometer	