

# Product Information Packet

November 9, 2016

Data shown is for the current revision model #. Ensure your nameplate model # matches.

<b>Model Number:</b>	<b>5KS145SAA302D</b>
<b>Catalog Number:</b>	<b>M498</b>
<b>Instruction Manual:</b>	GEI-56128
<b>Connection Diagram:</b>	GEM2034E-FIG3
<b>Outline Drawing:</b>	4002B5814PBP5316

Accessory Connection Diagrams			
<b>Bearing Thermocouple:</b>	None	<b>Heater:</b>	None
<b>RTD:</b>	None	<b>Thermistor:</b>	None
<b>Thermostat:</b>	None	<b>Winding Thermocouple:</b>	None
<b>Bearing RTD:</b>	None		

## Table of Contents

Specification	01
Performance Characteristics	02
Outline Drawing	03
Connection Drawing(s)	04
Spare parts	05



**Marks:**

<b>MODEL NUMBER:</b>	<b>5KS145SAA302D</b>	<b>Estimated Weight:</b>	50 Lbs
<b>Outline Drawing:</b>	4002B5814PBP5316	<b>Time Rating:</b>	CONT
<b>Connection Diagram:</b>	GEM2034E-FIG3	<b>Enclosure:</b>	TEFC
<b>Instruction Book:</b>	GEI-56128	<b>Encl Construction:</b>	X\$D
<b>Design Code:</b>	14BD3013AA	<b>Ambient Max(°C):</b>	40
<b>Type:</b>	KS	<b>Alt Ambient Max(°C):</b>	65
<b>Frame:</b>	145TC	<b>Insulation Class:</b>	H
<b>Phases:</b>	3	<b>NEMA Design:</b>	B
<b>Poles:</b>	6	<b>Nominal Efficiency:</b>	82.5 %
<b>Output Power:</b>	1HP 0.7KW	<b>Guaranteed Efficiency:</b>	81.5
<b>RPM:</b>	1155	<b>3/4 Load Efficiency:</b>	82.8
<b>Voltage:</b>	230/460	<b>KVA Code:</b>	N
<b>Hertz:</b>	60	<b>Max KVAR:</b>	0.9
<b>Amps - FL:</b>	3.6/1.8	<b>Power Factor:</b>	62.5
<b>Service Factor:</b>	1.25	<b>Bearing - DE:</b>	6206ZC3
<b>Alt Service Factor:</b>	1.00	<b>Bearing - ODE:</b>	6205ZC3

**Enclosure is Totally Enclosed Fan-Cooled**

**Stamped Nameplate Notes:**

SF AMPS 4.1/2.1  
 STAMP NP249A5564P051 AS BELOW:  
 MODEL:5KS145SAA302D S/N: XXX  
 CSA CERTIFIED CSA09.2216219 FOR EX NA IIC 200C GC  
 CL 1 ZONE2 AEX NA IIC 200C;CL 1 DIV2 GRP ABCD 200C  
 IN -25C <= AMB <= 40C, 1.0 SF ON SINE-WAVE PWR  
 SURF TEMP 200C AT 1.25SF ON SINE-WAVE PWR  
 OR 200 C VT OR 200 C CT OR 200 C CHP PWM CONTROL  
 ALTERNATE RATING FOR PWM CONTROL 1.0SF 40C AMB  
 VT 0-60 HZ, CT 3-60 HZ , CHP 60-90 HZ.

**Additional Information:**

6P - T EXTN  
 STANDARD FLOOR MOUNT  
 C/BOX 30 CU IN-0.75 NPT  
 F1 CONDUIT BOX MOUNTING  
 "C" FACE AT DE ENDSHIELD  
 INPRO SEAL DE ONLY  
 OIL RESISTANT SLEEVING ON LEADS

**Performance Characteristics**

1st Winding 1st Connection

**Design: 14BD3013AA**

**Marks:**

LOAD %	125.0	115.0	100.0	75.0	50.0	25.0	0.0
% EFF	82.2	82.65	83.26	82.78	80.19	70.59	0.00
% PF	68.89	66.52	64.14	53.09	40.71	25.06	7.05
AMPS	2.07	1.96	1.75	1.6	1.43	1.32	1.2

<b>TORQ(FL)#FT</b>	4.55	<b>TORQ(LR)%FL</b>	337.79	<b>TORQ(BD)%FL</b>	386.95
<b>AMPS(LR)</b>	10.05	<b>PF AT START</b>	0.59		

This motor is capable of two cold or one hot start with a maximum connected load inertia of 218 Lb-Ft Sq (9.18 Kg-meter Sq)at 100% voltage, where the load torque varies with the square of the speed. Acceleration time with maximum inertia and the above load type is 59 seconds. Safe stall time at 100% voltage is 131 seconds cold, 101 seconds hot. Rotor inertia is 0.11 Lb-Ft Sq (0 Kg-meter Sq).

<b>Open Circuit A-C:</b>	0.079	<b>Short Circuit D-C:</b>	0.006
<b>Short Circuit A-C:</b>	0.007	<b>X/R Ratio:</b>	2.353
<b>Stator Slots:</b>	36	<b>Rotor Slots:</b>	48

**Speed Torque Current Curve (First Connection, First Speed)**

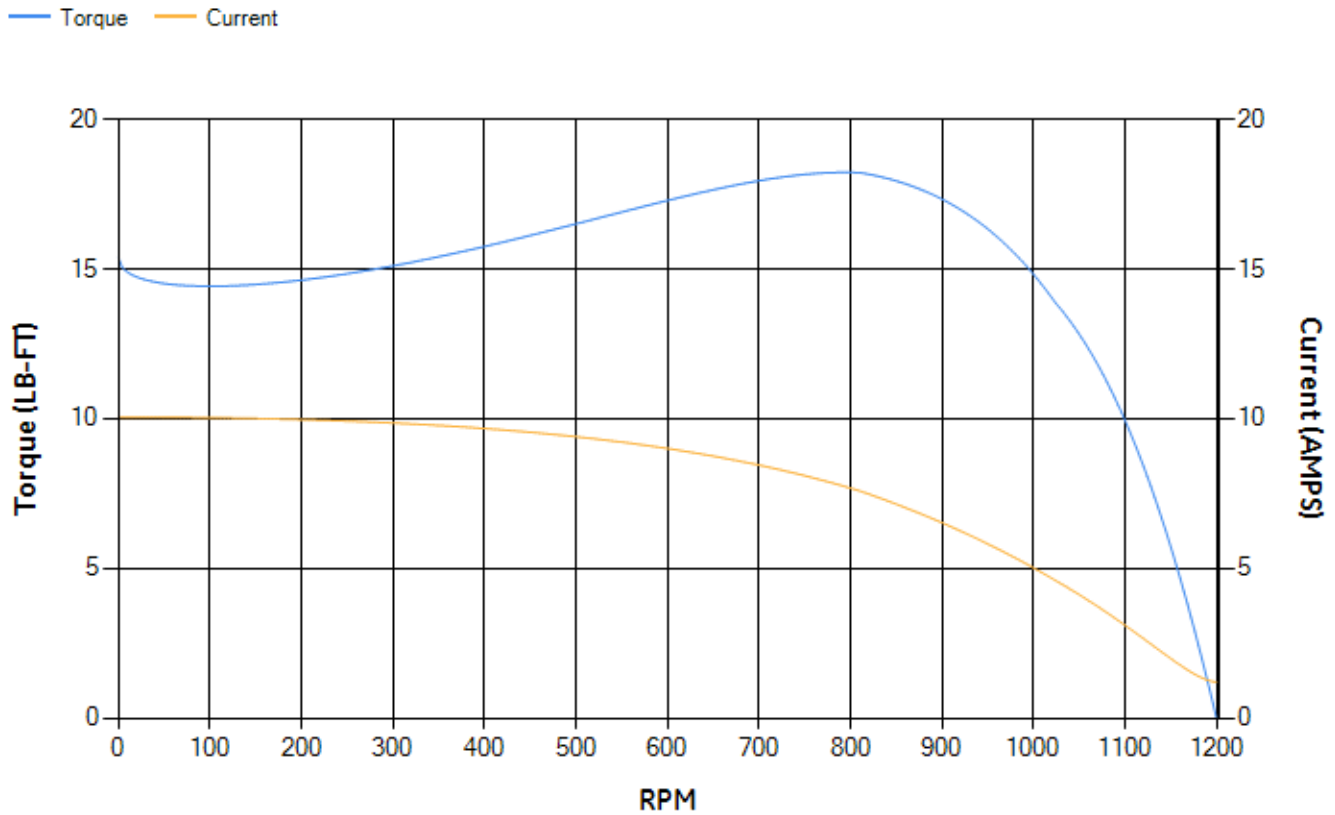



Marks:

**Connection Diagram**  
**GEM2034E-FIG3**

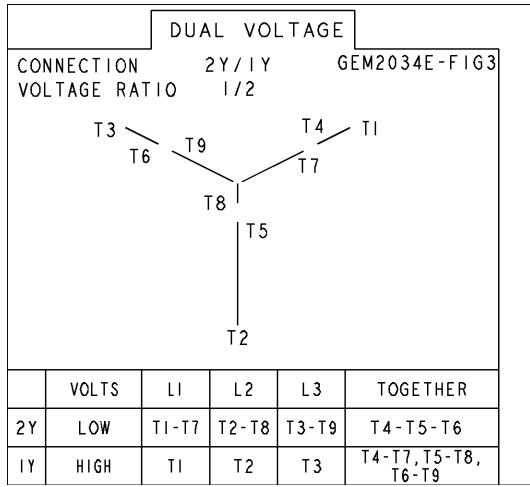

End shield Assembly		
Part Description	DE Side Part#	ODE Side Part#
End Shield	4004D5289PB1	4004D5280SG1
Bearing	235A2602AA01	235A2600AA01
Slinger/Inproseal	4002B5914AM1	149C4399G15

Fan & Fan Cover Assembly	
Part Description	Part#
Fan	4001A5914AM-G01
Fan Cover	4003C5785PA1

Conduit & Accessories Box Assembly	
Part Description	Part#
Conduit Box	4002B5718PA-G01

Mechanical Accessories	
Part Description	Part#
Brake	
Tachometer	