

# Product Information Packet

April 27, 2017

Data shown is for the current revision model #. Ensure your nameplate model # matches.

<b>Model Number:</b>	<b>5KS449DAJ6021A</b>
<b>Catalog Number:</b>	<b>V4532</b>
<b>Instruction Manual:</b>	GEK-95352
<b>Connection Diagram:</b>	GEM2034E-FIG19
<b>Outline Drawing:</b>	148CB49VMJKFGLA0001

## Accessory Connection Diagrams

<b>Bearing Thermocouple:</b>	None	<b>Heater:</b>	3027JE-1C
<b>RTD:</b>	None	<b>Thermistor:</b>	None
<b>Thermostat:</b>	3027JE-2A	<b>Winding Thermocouple:</b>	None
<b>Bearing RTD:</b>	None		

## Table of Contents

Specification	01
Performance Characteristics	02
Outline Drawing	03
Connection Drawing(s)	04
Spare parts	05



**Marks:**

<b>MODEL NUMBER:</b>	<b>5KS449DAJ6021A</b>	<b>Estimated Weight:</b>	3600 Lbs
<b>Outline Drawing:</b>	148CB49VMJKFGLA0001	<b>Time Rating:</b>	CONT
<b>Connection Diagram:</b>	GEM2034E-FIG19	<b>Enclosure:</b>	WPI
<b>Instruction Book:</b>	GEK-95352	<b>Encl Construction:</b>	OPEN
<b>Design Code:</b>	49BD1253AB	<b>Ambient Max(°C):</b>	40
<b>Type:</b>	KS	<b>Alt Ambient Max(°C):</b>	--
<b>Frame:</b>	L449TP20	<b>Insulation Class:</b>	H
<b>Phases:</b>	3	<b>NEMA Design:</b>	B
<b>Poles:</b>	4	<b>Nominal Efficiency:</b>	95.8 %
<b>Output Power:</b>	400HP 296KW	<b>Guaranteed Efficiency:</b>	95.0
<b>RPM:</b>	1790	<b>3/4 Load Efficiency:</b>	96.6
<b>Voltage:</b>	460	<b>KVA Code:</b>	G
<b>Hertz:</b>	60	<b>Max KVAR:</b>	79.8
<b>Amps - FL:</b>	439.0	<b>Power Factor:</b>	89.0
<b>Service Factor:</b>	1.15	<b>Bearing - DE:</b>	6217C3
<b>Alt Service Factor:</b>	--	<b>Bearing - ODE:</b>	235A2536AB01

**Enclosure is Weather Protected One**

**Stamped Nameplate Notes:**

HTR LDS HE1-HE2 115V 145W  
 ROT CCW FACING ODE LEAD/PH SEQ 1-2-3/1-2-3  
 THERMOSTAT LEADS TB1-TB2 TRIP  
 INVERTER DUTY PER NEMA MG1 PART 31  
 ALTERNATE RATING FOR PWM CONTROL:1.0SF 40C AMBIENT  
 VAR TORQUE RANGE 5-60 HZ  
 SUITABLE FOR 350 HP, 380V, 50 HZ WITH  
 465.0 AMPS AND 1485 RPM AT 1.0 SF

**Additional Information:**

4 POLE, VERT HOLLOW SHAFT HIGH THRUST (2D)  
 SPECIAL BALANCE  
 2500 CU IN - 2(4.00" NPT)  
 BEARING LIFE 8760 HRS AT 20800 LB THRUST  
 C/B GRD PLATE  
 OIL RESISTANT SLEEVING ON LEADS  
 N.C. TRIP TSTAT LDS TO MAIN CONDUIT BOX  
 115V HTR LDS TO MAIN CONDUIT BOX  
 COUPLING NOT INCLUDED IN BOM, WILL BE  
 ORDERED SEPERATELY  
 PART WINDING START  
 AEGIS GROUNDING RING MOUNTED ON LOWER END BEARING CAP  
 GROUND PAD ON FRAME  
 INSULATED LOWER HALF COUPLING

**Performance Characteristics**

1st Winding 1st Connection

**Design: 49BD1253AB**

**Marks:**

LOAD %	125.0	115.0	100.0	75.0	50.0	25.0	0.0
% EFF	94.74	95.04	95.61	95.83	95.77	94.06	0.00
% PF	88.74	88.95	88.9	87.44	82.23	64.27	4.39
AMPS	556.57	509.3	440.45	335.08	237.71	154.82	111.26

<b>TORQ(FL)#FT</b>	1174.58	<b>TORQ(LR)%FL</b>	117.72	<b>TORQ(BD)%FL</b>	233.56
<b>AMPS(LR)</b>	2518.98	<b>PF AT START</b>	0.25		

This motor is capable of two cold or one hot start with a maximum connected load inertia of 4732 Lb-Ft Sq (199.22 Kg-meter Sq)at 100% voltage, where the load torque varies with the square of the speed. Acceleration time with maximum inertia and the above load type is 32 seconds. Safe stall time at 100% voltage is 85 seconds cold, 48 seconds hot. Rotor inertia is 130.07 Lb-Ft Sq (5.48 Kg-meter Sq).

<b>Open Circuit A-C:</b>	1.587	<b>Short Circuit D-C:</b>	0.026
<b>Short Circuit A-C:</b>	0.063	<b>X/R Ratio:</b>	9.867
<b>Stator Slots:</b>	72	<b>Rotor Slots:</b>	58

**Speed Torque Current Curve (First Connection, First Speed)**

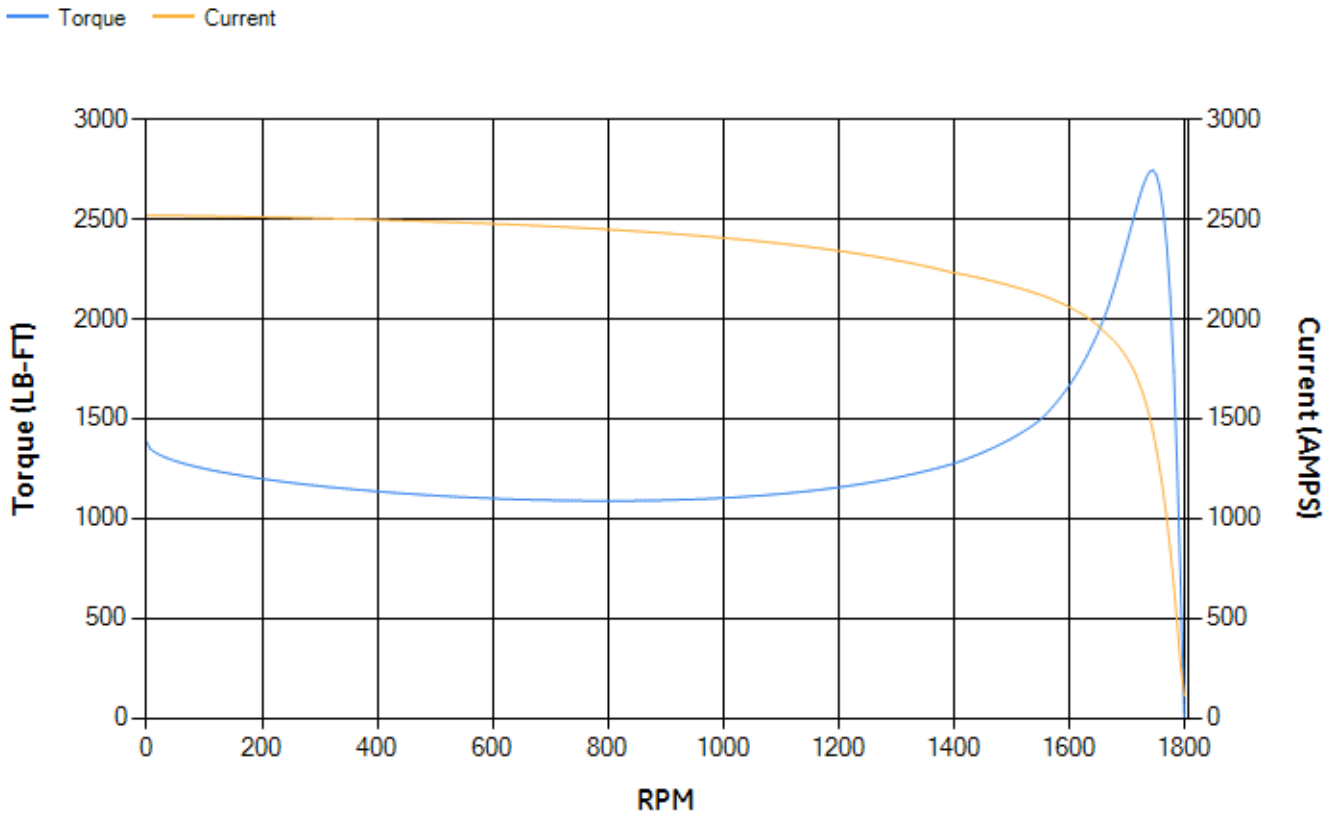

Marks:

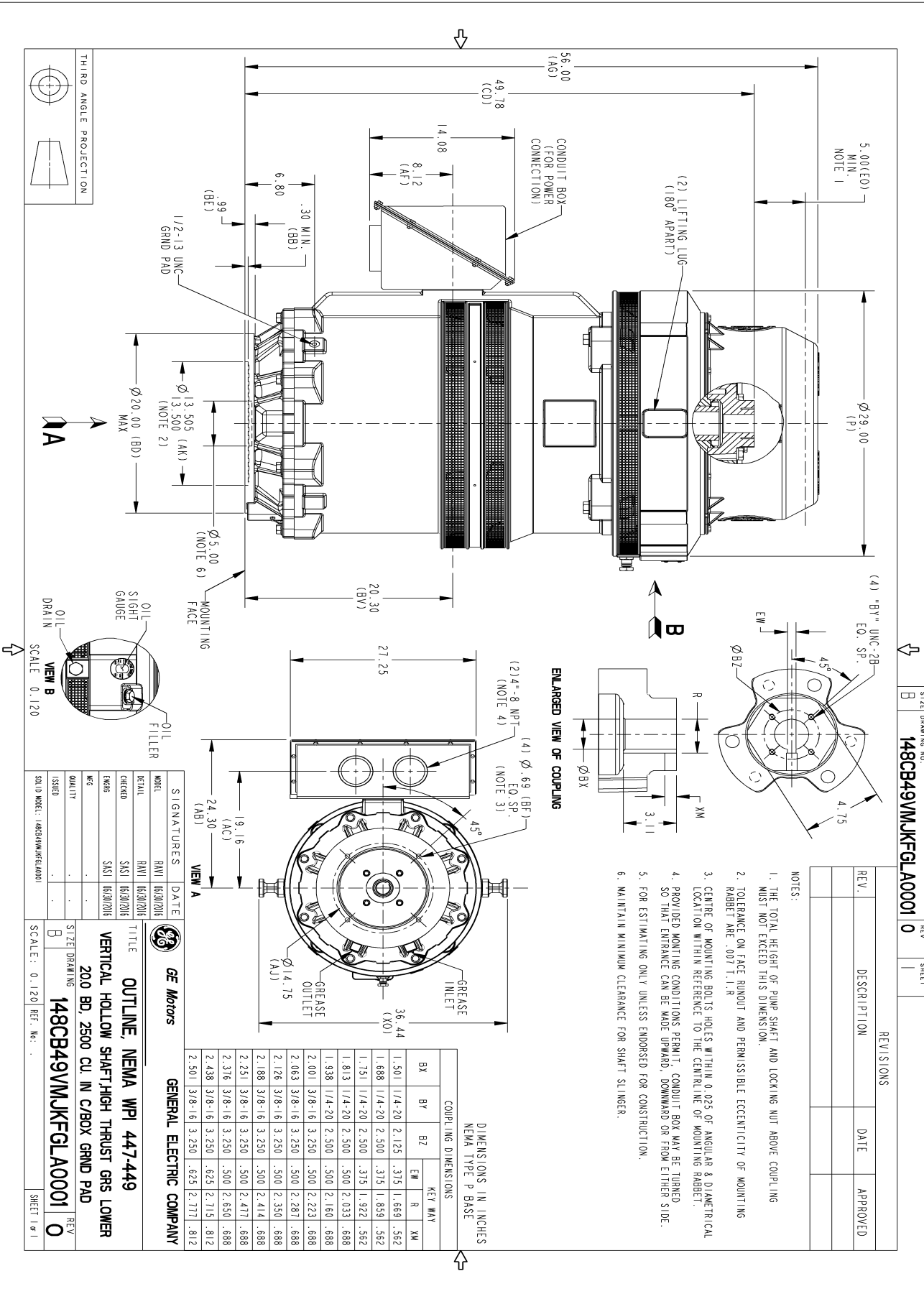

Marks:

**Connection Diagram**  
**GEM2034E-FIG19**

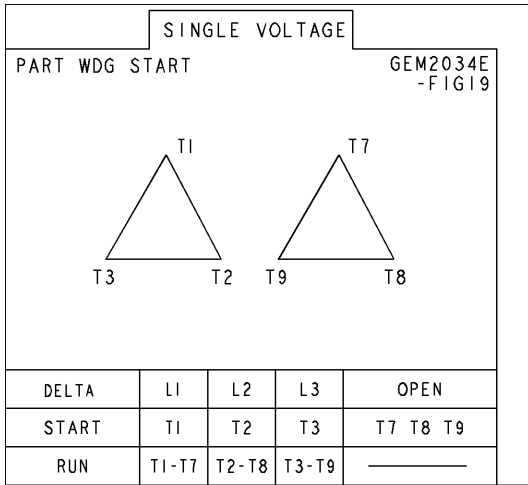

**Heater Connection**  
**3027JE-1C**

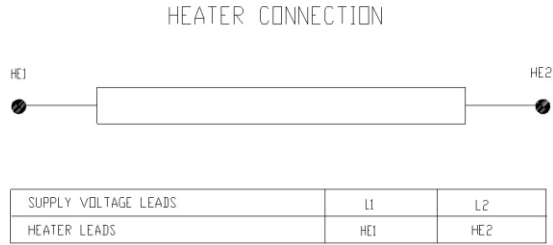

**Thermostat Connection**  
**3027JE-2A**

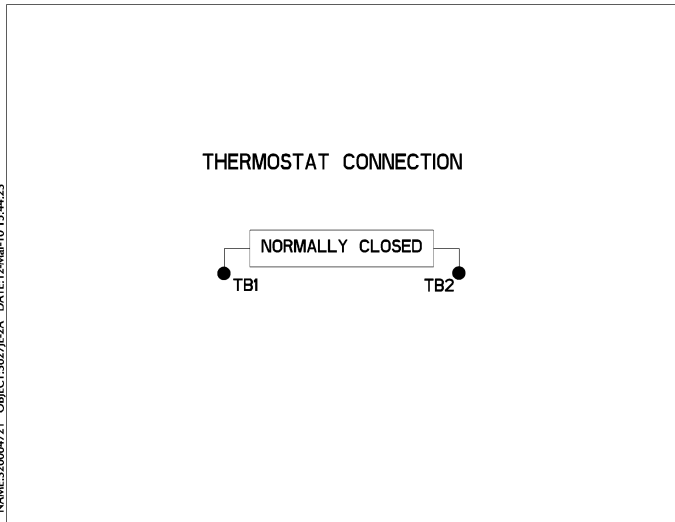

NAME:32000471 OBJECT:3027JE-2A DATE:12-Mar-10 15:44:23

End shield Assembly		
Part Description	DE Side Part#	ODE Side Part#
End Shield	115E7661AA1	115E7670LA1
Bearing	235A2522AJ01	235A2536AB01
Slinger/Inproseal		

Fan & Fan Cover Assembly	
Part Description	Part#
Fan	
Fan Cover	149C4050AA1

Conduit & Accessories Box Assembly	
Part Description	Part#
Conduit Box	179B9052G01

Mechanical Accessories	
Part Description	Part#
Brake	
Tachometer	