

031780

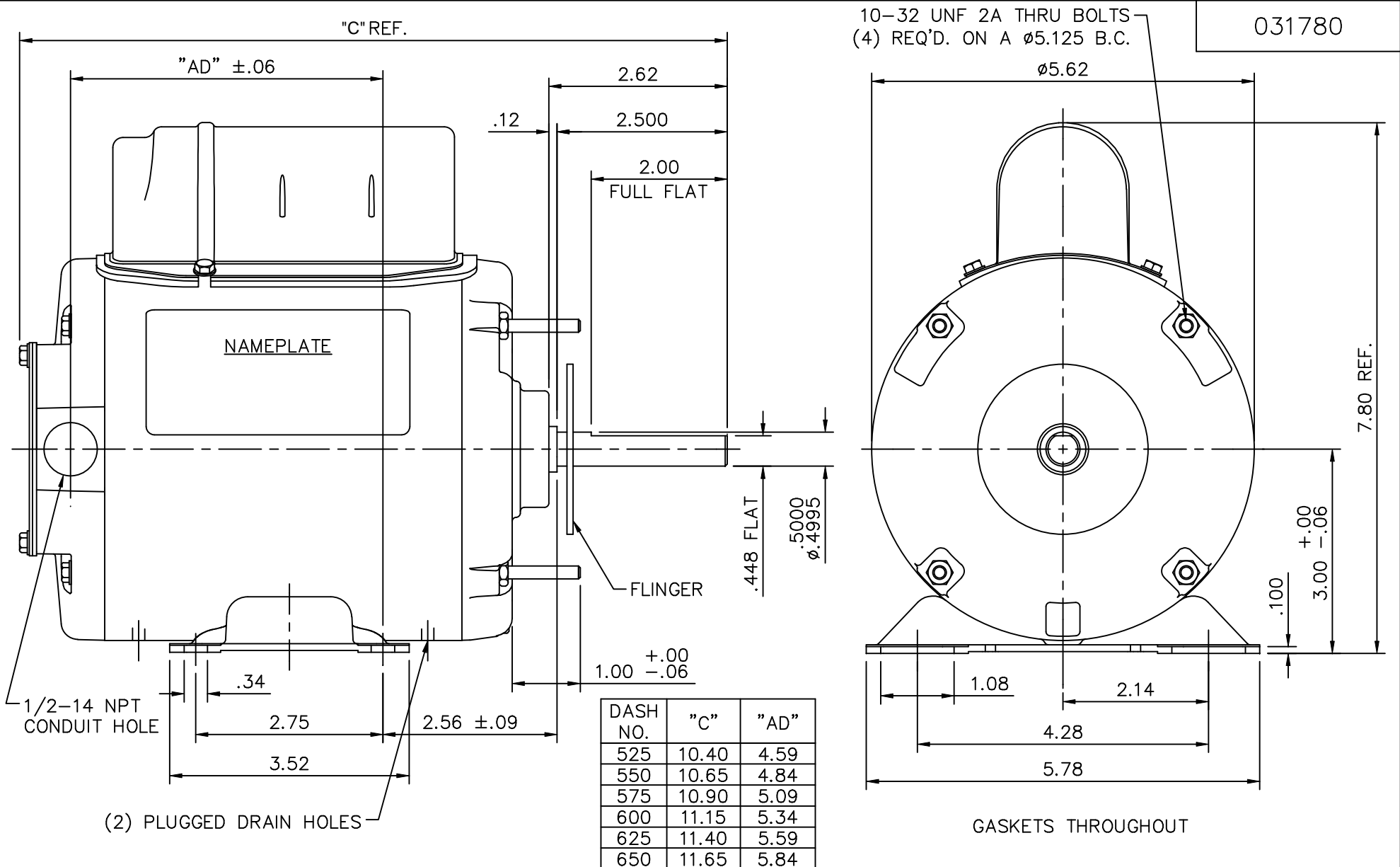

| DASH NO. | "C" | "AD" |
|----------|-------|------|
| 525 | 10.40 | 4.59 |
| 550 | 10.65 | 4.84 |
| 575 | 10.90 | 5.09 |
| 600 | 11.15 | 5.34 |
| 625 | 11.40 | 5.59 |
| 650 | 11.65 | 5.84 |

| TOLERANCES UNLESS SPECIFIED | |
|-----------------------------|--------|
| DEC. | INCHES |
| .X | ±.1 |
| .XX | ±.03 |
| .XXX | ±.005 |
| .XXXX | ±.0005 |
| ANG | ±1/2° |



ELECTRIC MOTORS
GEARMOTORS
AND DRIVES

| | |
|-------|-----------|
| DRAWN | PG 8/3/04 |
| CHK | |
| APPD | |
| SCALE | 1=2 |
| REF | 031707 |
| FMF | 101252.00 |
| PREV | |

| | |
|--------|---|
| TITLE | OUTLINE - 48Y FRAME RIGID MOUNT - ENCLOSED |
| MAT'L. | 1 PHASE |
| FINISH | STANDARD |

| NO. | REVISION | BY & DATE | CHK |
|-----|----------|-----------|-----|
| | | | |

THIS DRAWING IN DESIGN AND DETAIL IS OUR PROPERTY AND MUST NOT BE USED EXCEPT IN CONNECTION WITH OUR WORK ALL RIGHTS OF DESIGN AND INVENTION ARE RESERVED THIS IS AN ELECTRONICALLY GENERATED DOCUMENT - DO NOT SCALE THIS PRINT

| | | | | | |
|------|----------|--------|------|-------------|------|
| RFP | CAD FILE | 031780 | SIZE | DRAWING NO. | REV. |
| DIST | | | A | 031780 | |