

Product Information Packet

November 9, 2016

Data shown is for the current revision model #. Ensure your nameplate model # matches.

Model Number:	5KS182XAE5420C
Catalog Number:	V854
Instruction Manual:	GEK-95351
Connection Diagram:	GEM2034E-FIG1
Outline Drawing:	4002B5818PNP5323

Accessory Connection Diagrams			
Bearing Thermocouple:	None	Heater:	None
RTD:	None	Thermistor:	None
Thermostat:	None	Winding Thermocouple:	None
Bearing RTD:	None		

Table of Contents

Specification	01
Performance Characteristics	02
Outline Drawing	03
Connection Drawing(s)	04
Spare parts	05



Marks:

MODEL NUMBER:	5KS182XAE5420C	Estimated Weight:	76 Lbs
Outline Drawing:	4002B5818PNP5323	Time Rating:	CONT
Connection Diagram:	GEM2034E-FIG1	Enclosure:	TEFC
Instruction Book:	GEK-95351	Encl Construction:	841
Design Code:	18BD0104A	Ambient Max(°C):	40
Type:	KS	Alt Ambient Max(°C):	--
Frame:	L182VP10	Insulation Class:	H
Phases:	3	NEMA Design:	B
Poles:	2	Nominal Efficiency:	86.5 %
Output Power:	3HP 2.2KW	Guaranteed Efficiency:	84.0
RPM:	3530	3/4 Load Efficiency:	87.1
Voltage:	460	KVA Code:	K
Hertz:	60	Max KVAR:	1.1
Amps - FL:	4.0	Power Factor:	82.0
Service Factor:	1.15	Bearing - DE:	7307
Alt Service Factor:	--	Bearing - ODE:	6206-2ZC3

Enclosure is Totally Enclosed Fan-Cooled

Stamped Nameplate Notes:

VERTICAL-841
 PREMIUM EFFICIENT MOTOR
 DE BRG 35BT03XP3 ODE BRG 30BC02JP3
 SEVERE DUTY
 EXCEPTION TO IEEE-STD-841-2009:THRUST BRG ON DE
 INVERTER DUTY PER NEMA MG1 PART 31
 ALTERNATE RATING FOR PWM CONTROL:
 1.0 SF VAR TORQUE RANGE 0-60 HZ
 MAX EXPOSED INTERNAL AND EXTERNAL SURFACE
 TEMPERATURES UNDER USUAL SERVICE CONDITIONS
 AT 1.00 S.F. DO NOT EXCEED 200 DEG C
 STAMP NP249A5499AP AS BELOW:
 MODEL:5KS182XAE5420C S/N: XXX
 EX NA IIC T3 GC CSA.09.2216219
 CLASS I, ZONE 2, AEX NA IIC T3
 CLASS I, DIV 2, GROUPS A, B, C, D T3
 -25C <= TAMB <= 40C

Additional Information:

2P - VP EXTN
 C/BOX 55 CU IN-1.00 NPT
 PAINTED FRAME ID & SHAFT,
 FAN COVER INSIDE & ODE E/S OUTSIDE
 ROUTINE AND 5 POINT VIBRATION TESTS INCL IN C/BOX
 INPRO SEAL BOTH ENDS
 BURNDY SERVIT POST ON FRAME
 SHAFT RUNOUT LIMIT .001" TIR

RCF 5000 CPM, STATIC DEFLECTION .0014 INCHES &
CENTER OF GRAVITY 6.5 INCHES
SOLID SHAFT HIGH THRUST
COPPER WASHER UNDER HEADS OF BEARING CAP BOLTS
APPLY TITE-SEAL (A50CD427A) ON BEARING CAP SCREWS, RABBETS,
AND PLUG THREADS
OIL RESISTANT SLEEVING ON LEADS
BEARING LIFE 26280 HOURS AT 960.4 LB THRUST

Performance Characteristics

1st Winding 1st Connection

Design: 18BD0104A

Marks:

LOAD %	125.0	115.0	100.0	75.0	50.0	25.0	0.0
% EFF	87.06	87.32	87.71	87.09	84.83	76.66	0.00
% PF	84.31	83.54	85.35	76.76	66.53	46.21	13.09
AMPS	4.78	4.43	3.75	3.15	2.49	1.98	1.49

TORQ(FL)#FT	4.46	TORQ(LR)%FL	188.9	TORQ(BD)%FL	316.66
AMPS(LR)	24.66	PF AT START	0.4		

This motor is capable of two cold or one hot start with a maximum connected load inertia of 38 Lb-Ft Sq (1.6 Kg-meter Sq) at 100% voltage, where the load torque varies with the square of the speed. Acceleration time with maximum inertia and the above load type is 60 seconds. Safe stall time at 100% voltage is 116 seconds cold, 97 seconds hot. Rotor inertia is 0.12 Lb-Ft Sq (0.01 Kg-meter Sq).

Open Circuit A-C:	0.329	Short Circuit D-C:	0.01
Short Circuit A-C:	0.018	X/R Ratio:	3.956
Stator Slots:	36	Rotor Slots:	28

Speed Torque Current Curve (First Connection, First Speed)

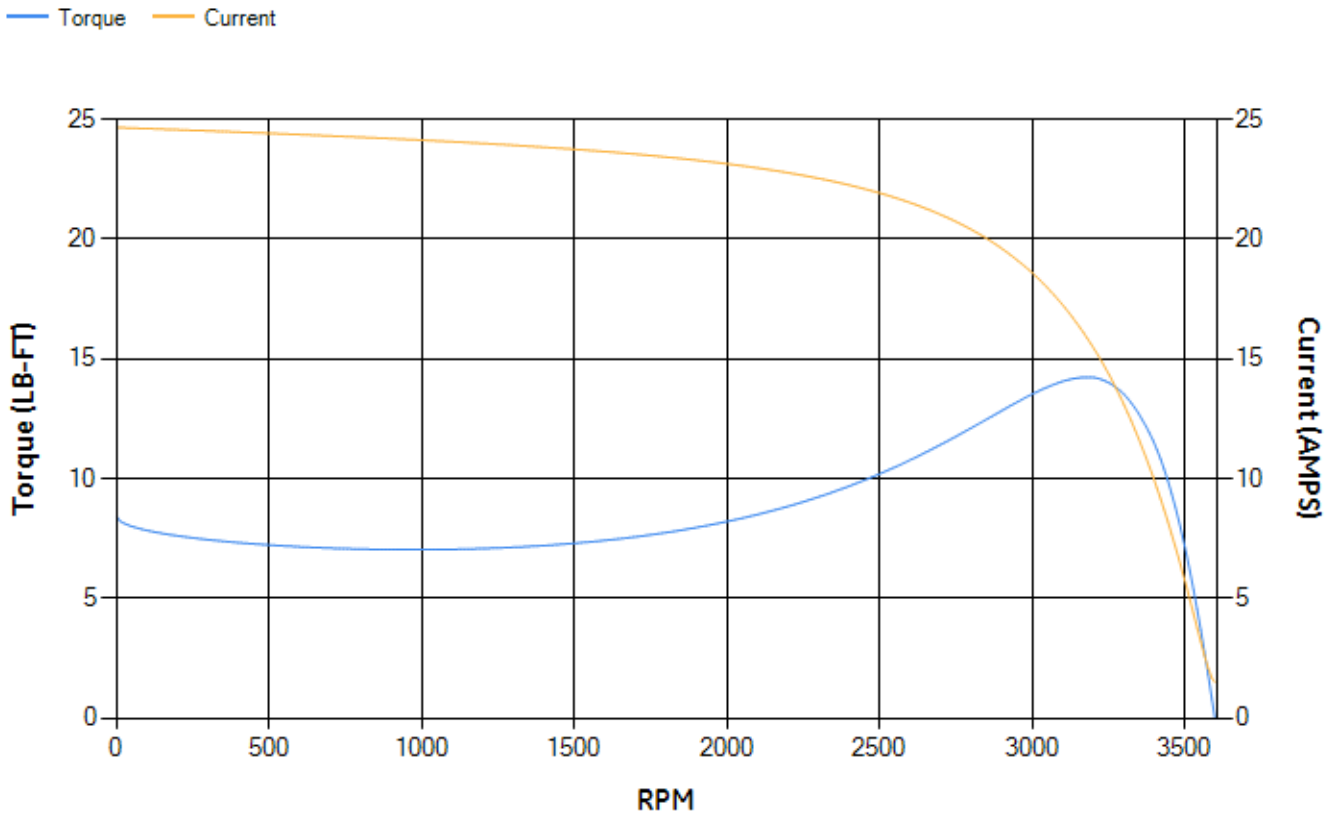

Marks:

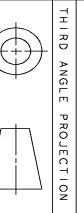
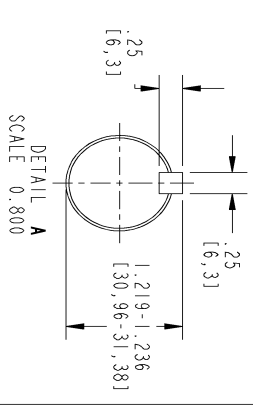
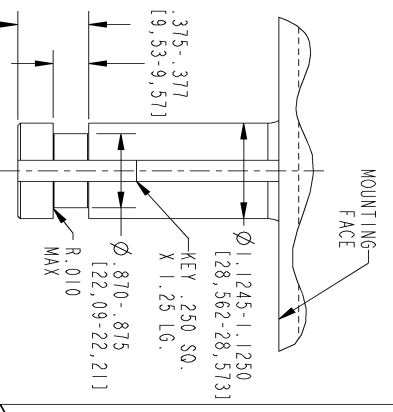
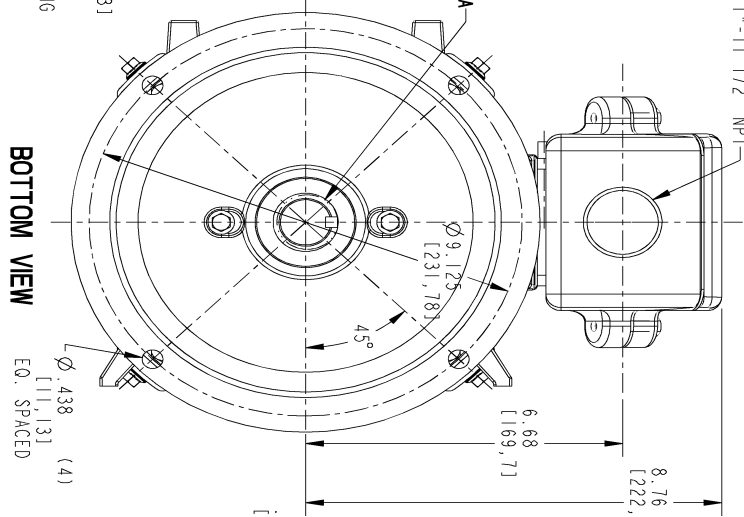
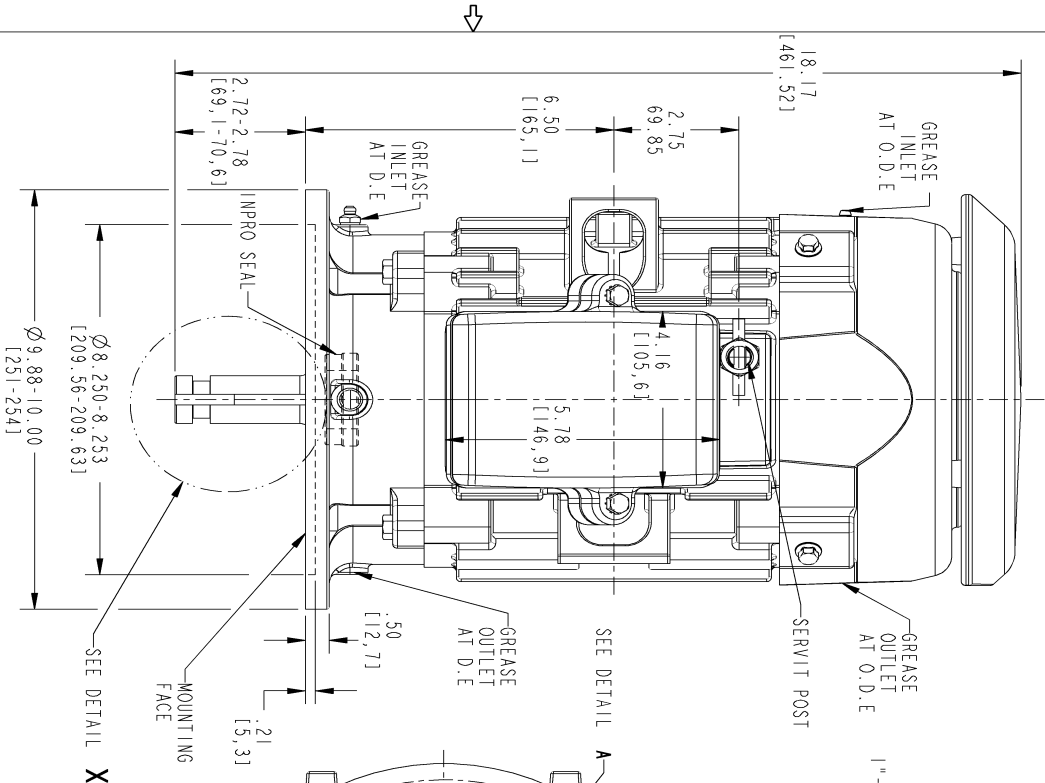

THIRD ANGLE PROJECTION

NOTE 1: ALL DIMENSIONS ARE IN INCHES. BRACKETED DIMENSIONS ARE IN METRIC (MILLIMETERS).
NOTE 2: SHAFT RUNOUT NOT TO EXCEED 0.001 T.I.R



B

SIZE DRAWING NO. 4002B5818PMP5323

REV 1

SHEET 1

REV.	DESCRIPTION	DATE	APPROVED
1	ISAC #16-0423 DEEPAWANI	05/04/2016	KARTHIK

SIGNATURES	DATE
HARI	02/21/13
HARI	02/21/13
MANCH	02/21/13
MANCH	02/21/13
HARI	02/21/13

GE Motors GENERAL ELECTRIC COMPANY
INDUCTION MOTOR OUTLINE
SOLID SHAFT-HIGH THRUST

FWE: FRL180VP TFC (BD-10) IEEE-841 SPEC
4002B5818PMP5323

SIZE DRAWING	REV
B	1

SCALE: 0.400 REF. No.: 4002B5818PMP5323 SHEET 1 of 1

Marks:

Connection Diagram
GEM2034E-FIG1



End shield Assembly		
Part Description	DE Side Part#	ODE Side Part#
End Shield	4004D5261PD1	4004D5281SD1
Bearing	235A2501AN01	235A2502AF01
Slinger/Inproseal	4002B5918CD1	4002B5914AG2

Fan & Fan Cover Assembly	
Part Description	Part#
Fan	346L620AP-G01
Fan Cover	4003C5518BN-G01

Conduit & Accessories Box Assembly	
Part Description	Part#
Conduit Box	4002B5721PA-G01

Mechanical Accessories	
Part Description	Part#
Brake	
Tachometer	