

Product Information Packet

January 12, 2017

Data shown is for the current revision model #. Ensure your nameplate model # matches.

Model Number:	5KGS444SAA220D2
Catalog Number:	M8995
Instruction Manual:	GEI-56128
Connection Diagram:	GEM2034E-FIG20
Outline Drawing:	239C6600AA

Accessory Connection Diagrams			
Bearing Thermocouple:	None	Heater:	None
RTD:	None	Thermistor:	None
Thermostat:	3027JE-2A	Winding Thermocouple:	None
Bearing RTD:	None		

Table of Contents

Specification	01
Performance Characteristics	02
Outline Drawing	03
Connection Drawing(s)	04
Spare parts	05



Marks:

MODEL NUMBER:	5KGS444SAA220D2	Estimated Weight:	1970 Lbs
Outline Drawing:	239C6600AA	Time Rating:	CONT
Connection Diagram:	GEM2034E-FIG20	Enclosure:	TEFC
Instruction Book:	GEI-56128	Encl Construction:	X\$D
Design Code:	44BD1160A	Ambient Max(°C):	40
Type:	KGS	Alt Ambient Max(°C):	--
Frame:	444T	Insulation Class:	H
Phases:	3	NEMA Design:	C
Poles:	4	Nominal Efficiency:	95.8 %
Output Power:	125HP 92.5KW	Guaranteed Efficiency:	95.4
RPM:	1780	3/4 Load Efficiency:	95.8
Voltage:	460	KVA Code:	G
Hertz:	60	Max KVAR:	36.7
Amps - FL:	143.0	Power Factor:	85.5
Service Factor:	1.15	Bearing - DE:	NU 318
Alt Service Factor:	--	Bearing - ODE:	6318ZC3

Enclosure is Totally Enclosed Fan-Cooled

Stamped Nameplate Notes:

ROLLER BEARING - FOR BELTED LOAD ONLY
 THERMOSTAT LEADS TB1-TB2 TRIP
 STAMP NP249A5564P051 AS BELOW:
 MODEL:5KGS444SAA220D2 S/N: XXX
 CSA CERTIFIED CSA09.2216219 FOR EX NA IIC 200 C GC
 CL 1 ZONE2 AEX NA IIC 200C;CL 1 DIV2 GRP ABCD 200C
 IN -40C <= AMB <= 40C, 1.0 SF ON SINE-WAVE PWR
 SURF TEMP 215C AT 1.15SF ON SINE-WAVE PWR
 OR 200C VT OR 230C CT OR ---C CHP PWM CONTROL
 ALTERNATE RATING FOR PWM CONTROL 1.0SF 40C AMB
 VT 0 - 60 HZ, CT 15-60 HZ, CHP -- HZ.

Additional Information:

4P - T EXTN - SPLIT LEAD
 700 CU IN - 3.00" NPT
 OIL RESISTANT SLEEVING ON LEADS
 B5F4C4 HIGH FATIGUE STEEL AISI 4142 SHAFT MATERIAL
 N.C. TRIP TSTAT LDS TO MAIN CONDUIT BOX
 F1 MOUNTING

Performance Characteristics

1st Winding 1st Connection

Design: 44BD1160A

Marks:

LOAD %	125.0	115.0	100.0	75.0	50.0	25.0	0.0
% EFF	95.2	95.4	95.84	95.83	95.49	93.25	0.00
% PF	86.73	86.37	85.35	81.7	72.86	50.77	3.53
AMPS	177.1	163.29	143.02	112.07	84.07	61.78	51.25

TORQ(FL)#FT	368.39	TORQ(LR)%FL	226.43	TORQ(BD)%FL	267.69
AMPS(LR)	881.57	PF AT START	0.4		

This motor is capable of two cold or one hot start with a maximum connected load inertia of 2358 Lb-Ft Sq (99.27 Kg-meter Sq)at 100% voltage, where the load torque varies with the square of the speed. Acceleration time with maximum inertia and the above load type is 23 seconds. Safe stall time at 100% voltage is 48 seconds cold, 27 seconds hot. Rotor inertia is 63.32 Lb-Ft Sq (2.67 Kg-meter Sq).

Open Circuit A-C:	0.692	Short Circuit D-C:	0.029
Short Circuit A-C:	0.032	X/R Ratio:	10.857
Stator Slots:	72	Rotor Slots:	58

Speed Torque Current Curve (First Connection, First Speed)

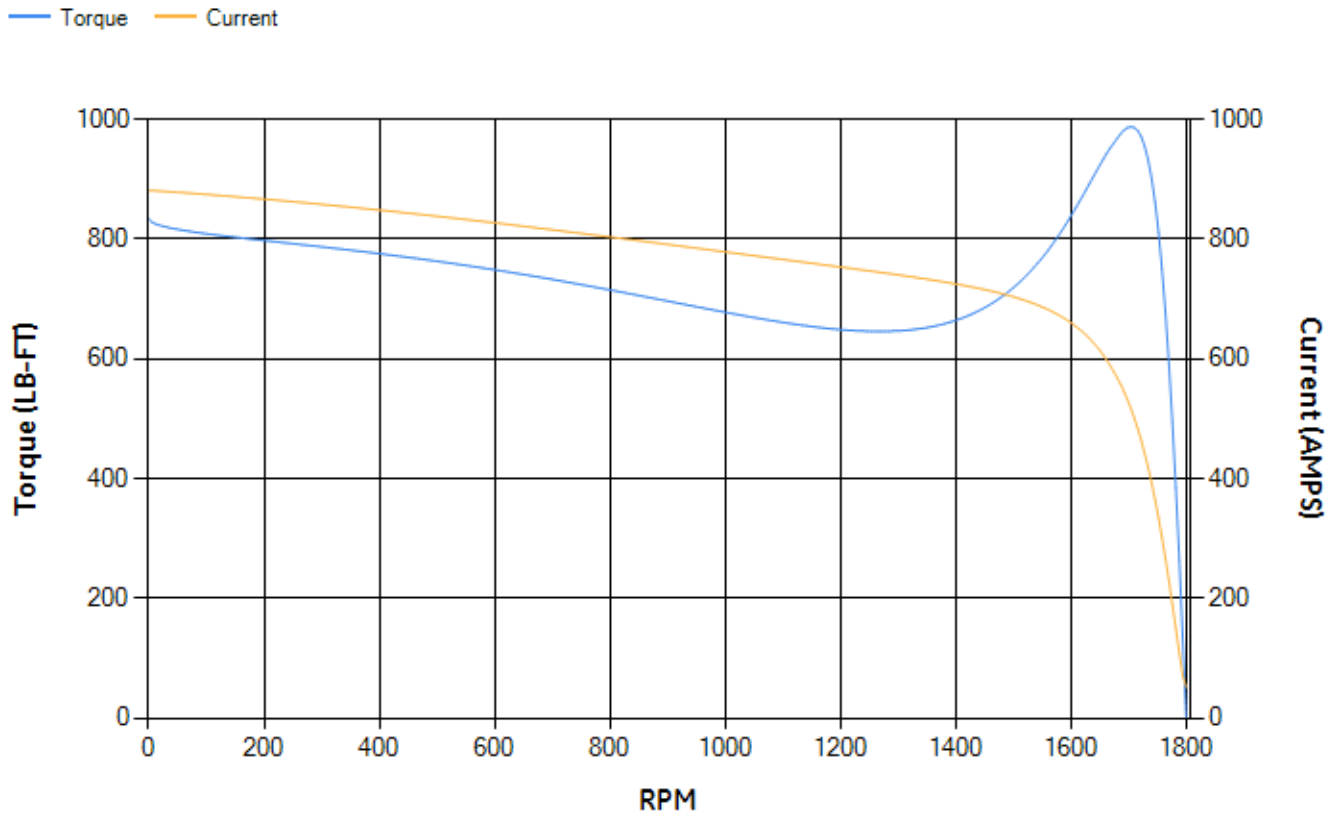

Marks:

REV.	DESCRIPTION	DATE	APPROVED
1	ECH 01-0311	02/05/01	
2	ADDED FAN COVER FIG. CPA	04/30/01	
3	SAC 02-0273 MARGAJ	02/04/02	
4	SAC 03-2024	08/06/03	
5	SAC 13-0248	03/22/13	

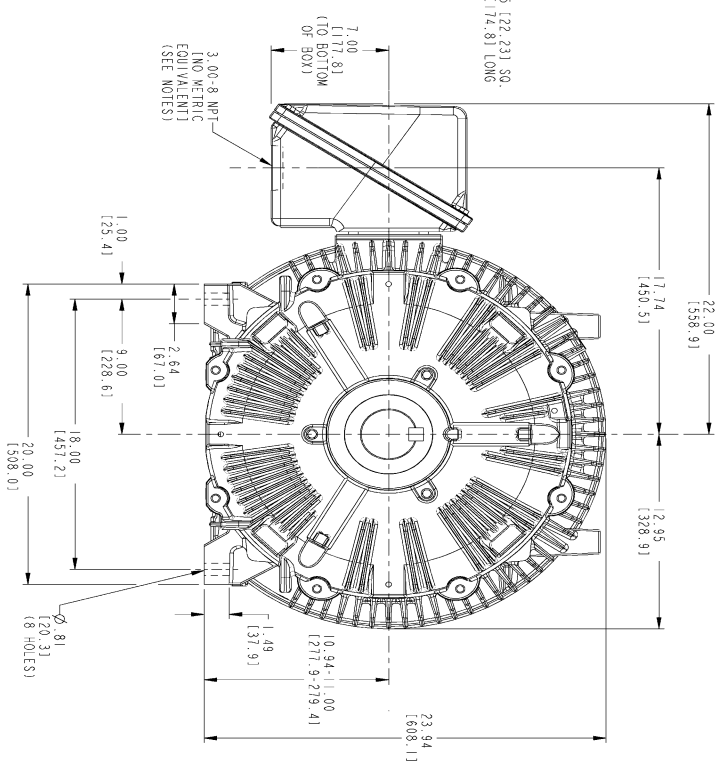
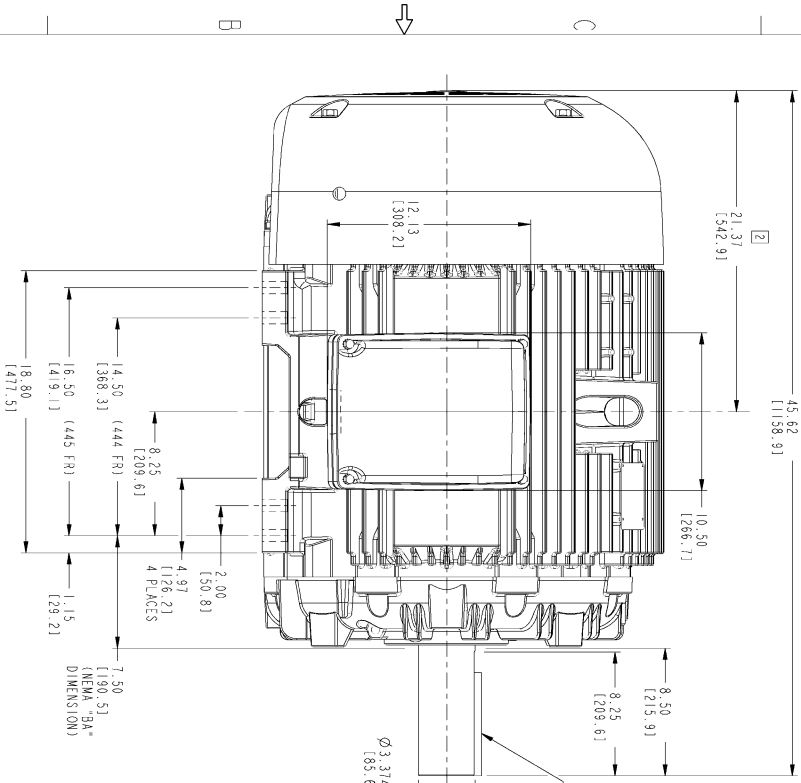

- NOTES:
- CONDUIT BOX MAY BE PLACED WITH THE ENTRANCE DOWN, UP OR ON EITHER SIDE.
 - F-1 ASSEMBLY AS SHOWN.
 - F-2 ASSEMBLY HAS CONDUIT BOX ON OPPOSITE SIDE.
 - BRACKETED DIMENSIONS ARE METRIC (MILLIMETERS).

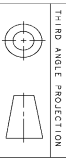

THIRD ANGLE PROJECTION

SIGNATURES	DATE	GE Industrial Systems	GENERAL ELECTRIC COMPANY
SALES J.M. JUREN 04/17/00			Fort Wayne, Indiana
ORDER M. ELSWORTH 04/17/00			
SALES D. STARK 04/17/00			
ORDER M. ELSWORTH 04/17/00			
APPLIED PRACTICES		SIZE DRAWING	
C		700 CU. IN. CONDUIT BOX	
SCALE: 0.200		REF. NO. 239C6600AA	
DISTRIBUTION: MMP		SHEET 1 OF 5	

Marks:

Connection Diagram
GEM2034E-FIG20

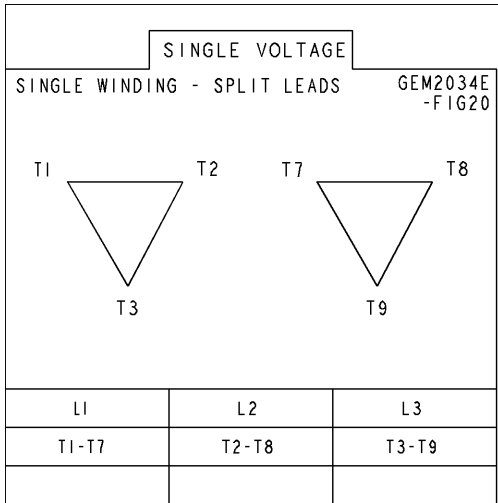

Thermostat Connection
3027JE-2A



End shield Assembly		
Part Description	DE Side Part#	ODE Side Part#
End Shield	115E4355AA1	115E4355LL1
Bearing	235A2519AA01	235A2514AG01
Slinger/Inproseal	149C4399G07	149C4399G07

Fan & Fan Cover Assembly	
Part Description	Part#
Fan	159C7100AA2
Fan Cover	128D6841AA1

Conduit & Accessories Box Assembly	
Part Description	Part#
Conduit Box	118D4408AD2

Mechanical Accessories	
Part Description	Part#
Brake	
Tachometer	