

Dimensional Drawing

Catalogue	Model	HP	Pole	kW	Rating	Voltage	Hz	RPM
PDH70025	AEHE	700	2	522	Continuous	575 V	60	3600

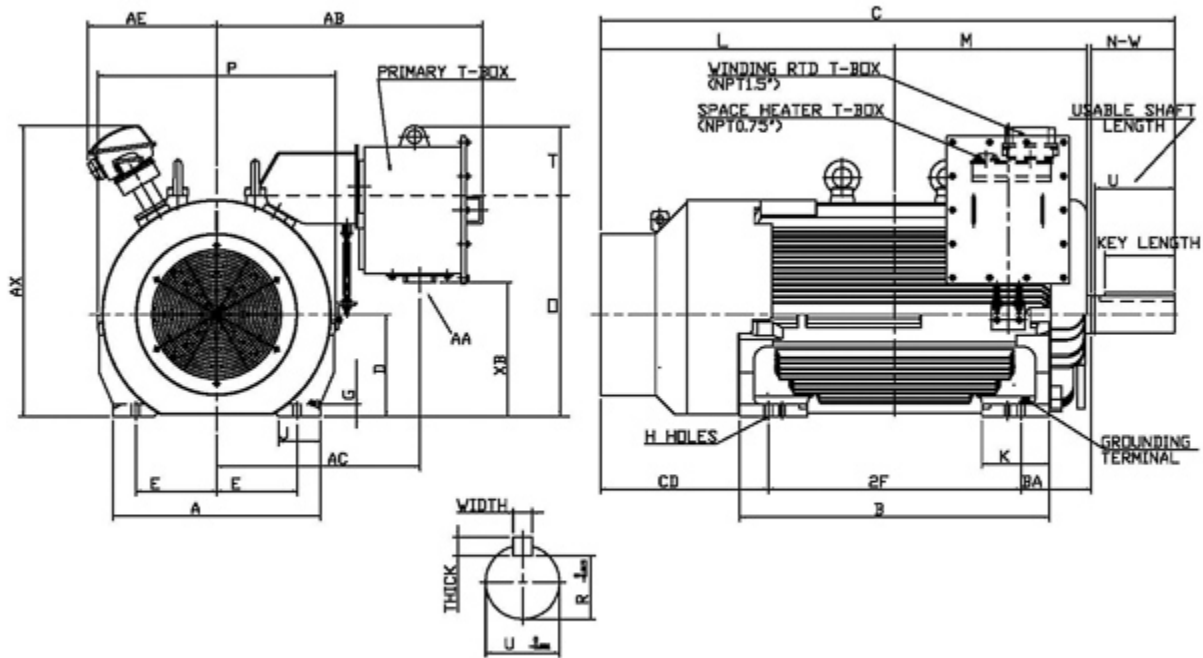

Frame Size	Mounting					A	B	C	CD	D	
	E	2F	2F2	H	BA						
5810A	11.5	36		1.13	10	29.55	44.1	81.4	29.64	14.5	
G	J	K	L	M	O	P	T	Key			Keyseat R
								Width	Thick	Length	
1.7	5.9	9.65	47.65	26.95	30.9	33.85	9.45	0.625	0.625	4.01	2.275
Terminal Housing			Aux Box			C/D Flange					
AA	AB	AC	XB	AE	AX	BB	AH	AK	BD	AJ	BF
2x 3 NPT	30.5	24.4	21.15	18.34	41.39						
Shaft Extension			Bearings		Approx. Weight Lbs	SPL dBA/3ft	Ins. Class	S.F.	Drive Method	Dimensions	
N-W	U	V	DE	NDE							
5.75	2.625	5.5	6315C3	6315/C3VL0241	6578	85	F	1.15	Direct Coupling	Inches	

Technical Data Sheet

Motor Type: AEHE

Catalogue No: PDH70025

Nameplate Information

HP	Pole	RPM	Frame	Voltage	Hz	Phase
700	2	3580	5810A	575	60	3
Enclosure	Ins. Class	Service Factor	Time Rating	NEMA Design	Rated Amb.	Rated Altitude
TEFC	F	1.15	Continuous	B	-40 to 40 °C	<3300 ft

Typical Performance

Efficiency (%)				Power Factor (%)		
Full Load		3/4 Load	1/2 Load	Full Load	3/4 Load	1/2 Load
Nom.	Min.					
95.5	94.6	95.2	94.5	90.5	88.5	75.0
Torque				Current (A)		
Full Load (lb-ft)	Locked Rotor (% FLT)	Pull Up (% FLT)	Break Down (% FLT)	No Load	Full Load	Locked Rotor
1026.54	80	80	230	126.4	606.7	4416
NEMA KVA Code	Inertia (WR ²)			Safe Stall Time (s)		Noise Level Sound Press. dB(A)
	Rotor (lb-ft ²)	NEMA Load (lb-ft ²)	Max. Allowable (lb-ft ²)	Cold	Hot	
0	175.000	503.0	503.0	25	19	85

VFD Duty Information

Speed Range			VFD		S.F.
Constant Torque	Variable Torque	Constant Power	Carrier	Type	
20-60Hz	3-60Hz	60-60Hz	≤ 5 kHz	VPWM or CPWM	

Additional Information

Hazardous Locations Information

Bearings		Approx. Weight	
DE	NDE	lbs	
6315C3	6315/C3VL0241	6578	N/A
			N/A
			N/A
Temp Code (Sinewave / VFD)			T3 (1.0 SF) / T2B