

# Product Information Packet

November 9, 2016

Data shown is for the current revision model #. Ensure your nameplate model # matches.

<b>Model Number:</b>	<b>5KS256SAA405D1</b>
<b>Catalog Number:</b>	<b>M9881</b>
<b>Instruction Manual:</b>	GEI-56128
<b>Connection Diagram:</b>	GEM2034E-FIG9
<b>Outline Drawing:</b>	4002B5825PAP5201

Accessory Connection Diagrams			
<b>Bearing Thermocouple:</b>	None	<b>Heater:</b>	None
<b>RTD:</b>	None	<b>Thermistor:</b>	None
<b>Thermostat:</b>	None	<b>Winding Thermocouple:</b>	None
<b>Bearing RTD:</b>	None		

## Table of Contents

Specification	01
Performance Characteristics	02
Outline Drawing	03
Connection Drawing(s)	04
Spare parts	05



**Marks:**

<b>MODEL NUMBER:</b>	<b>5KS256SAA405D1</b>	<b>Estimated Weight:</b>	350 Lbs
<b>Outline Drawing:</b>	4002B5825PAP5201	<b>Time Rating:</b>	CONT
<b>Connection Diagram:</b>	GEM2034E-FIG9	<b>Enclosure:</b>	TEFC
<b>Instruction Book:</b>	GEI-56128	<b>Encl Construction:</b>	X\$D
<b>Design Code:</b>	25BD4020A	<b>Ambient Max(°C):</b>	40
<b>Type:</b>	KS	<b>Alt Ambient Max(°C):</b>	50
<b>Frame:</b>	256T	<b>Insulation Class:</b>	H
<b>Phases:</b>	3	<b>NEMA Design:</b>	B
<b>Poles:</b>	8	<b>Nominal Efficiency:</b>	87.5 %
<b>Output Power:</b>	7.5HP 5.6KW	<b>Guaranteed Efficiency:</b>	86.5
<b>RPM:</b>	875	<b>3/4 Load Efficiency:</b>	89.2
<b>Voltage:</b>	230/460	<b>KVA Code:</b>	H
<b>Hertz:</b>	60	<b>Max KVAR:</b>	4.3
<b>Amps - FL:</b>	22.2/11.1	<b>Power Factor:</b>	72.0
<b>Service Factor:</b>	1.25	<b>Bearing - DE:</b>	6309ZC3
<b>Alt Service Factor:</b>	1.00	<b>Bearing - ODE:</b>	6309ZC3

**Enclosure is Totally Enclosed Fan-Cooled**

**Stamped Nameplate Notes:**

SF AMPS 26.8/13.4  
 STAMP NP249A5564P051 AS BELOW:  
 MODEL:5KS256SAA405D1 S/N: XXX  
 CSA CERTIFIED CSA09.2216219 FOR EX NA IIC 200C GC  
 CL 1 ZONE2 AEX NA IIC 200C;CL 1 DIV2 GRP ABCD 200C  
 IN -40C <= AMB <= 40C, 1.0 SF ON SINE-WAVE PWR  
 SURF TEMP 260C AT 1.25SF ON SINE-WAVE PWR  
 OR 200C VT OR 200C CT OR 200C CHP PWM CONTROL  
 ALTERNATE RATING FOR PWM CONTROL 1.0SF 40C AMB  
 VT 0 - 60 HZ, CT 3-60 HZ, CHP 60-90 HZ.

**Additional Information:**

8P - T EXTN  
 STANDARD FLOOR MOUNT  
 C/BOX 137 CU IN-1.25 NPT  
 F1 CONDUIT BOX MOUNTING  
 OIL RESISTANT SLEEVING ON LEADS

**Performance Characteristics**

1st Winding 1st Connection

**Design: 25BD4020A**

**Marks:**

LOAD %	125.0	115.0	100.0	75.0	50.0	25.0	0.0
% EFF	86.83	87.55	88.63	89.25	88.7	83.83	0.00
% PF	75.46	74.32	71.84	64.86	52.56	32.52	4.62
AMPS	13.39	12.41	11.03	9.09	7.53	6.44	5.93

<b>TORQ(FL)#FT</b>	44.98	<b>TORQ(LR)%FL</b>	154.61	<b>TORQ(BD)%FL</b>	242.97
<b>AMPS(LR)</b>	54.41	<b>PF AT START</b>	0.34		

This motor is capable of two cold or one hot start with a maximum connected load inertia of 1233 Lb-Ft Sq (51.91 Kg-meter Sq)at 100% voltage, where the load torque varies with the square of the speed. Acceleration time with maximum inertia and the above load type is 59 seconds. Safe stall time at 100% voltage is 142 seconds cold, 86 seconds hot. Rotor inertia is 2.11 Lb-Ft Sq (0.09 Kg-meter Sq).

<b>Open Circuit A-C:</b>	0.166	<b>Short Circuit D-C:</b>	0.012
<b>Short Circuit A-C:</b>	0.017	<b>X/R Ratio:</b>	4.461
<b>Stator Slots:</b>	54	<b>Rotor Slots:</b>	70

**Speed Torque Current Curve (First Connection, First Speed)**

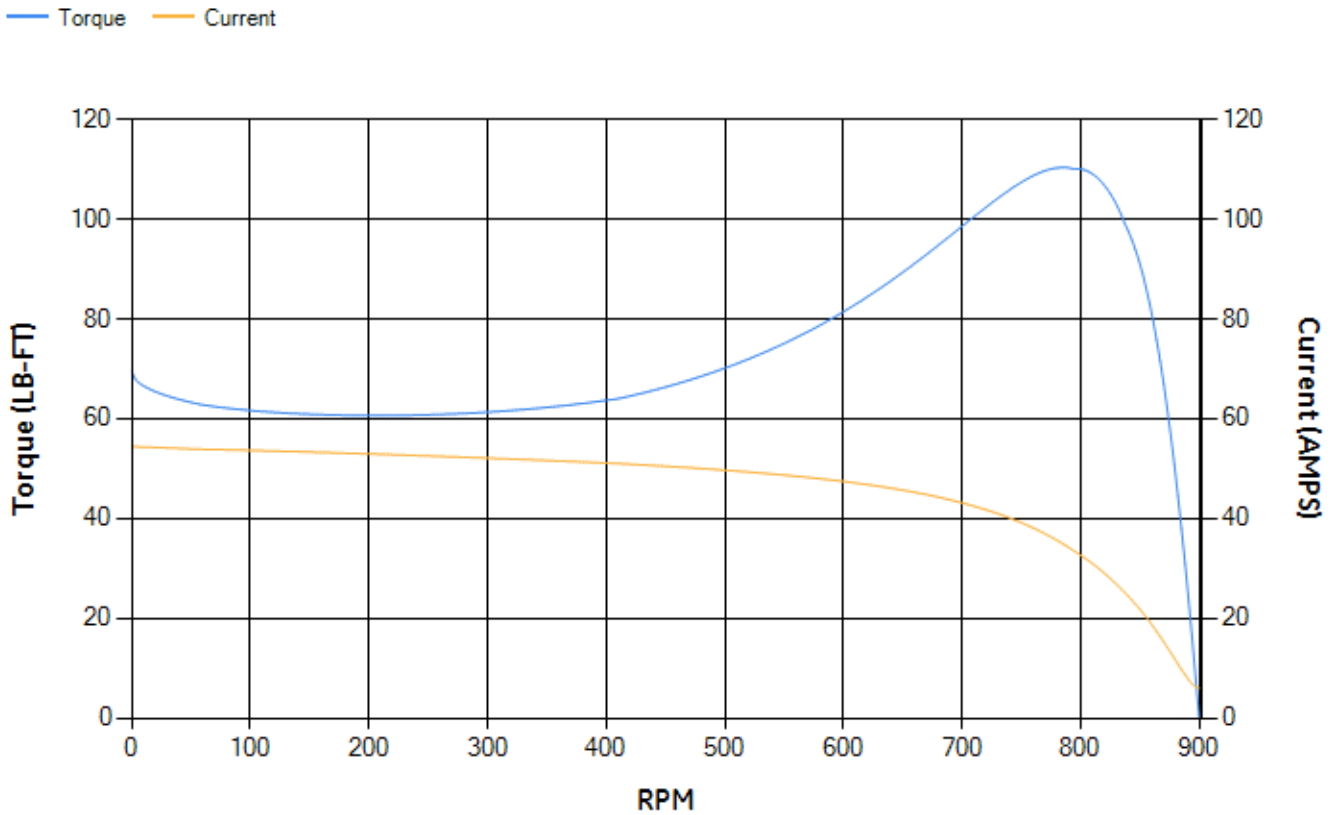

Marks:

NOTE 1: CONDUIT BOX MAY BE ASSEMBLED WITH ENTRANCE UP, DOWN OR TO EITHER SIDE.  
 NOTE 2: F1 ASSEMBLY AS SHOWN. F2 ASSEMBLY CONDUIT BOX ON OPPOSITE SIDE FROM SHOWN LOCATION.  
 NOTE 3: SHAFT RUNOUT WILL NOT EXCEED .002 T.I.R.

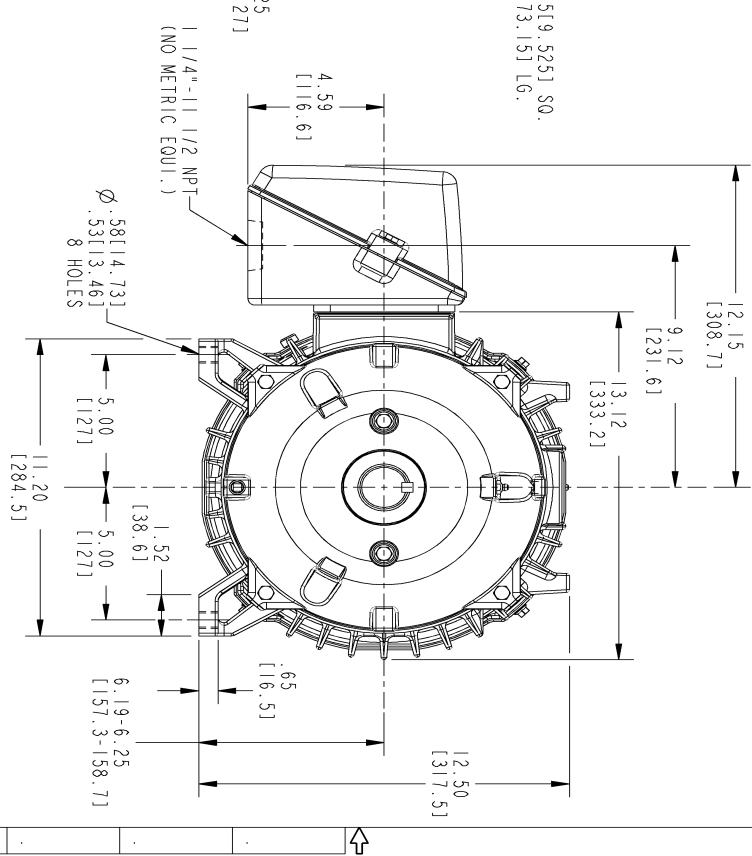
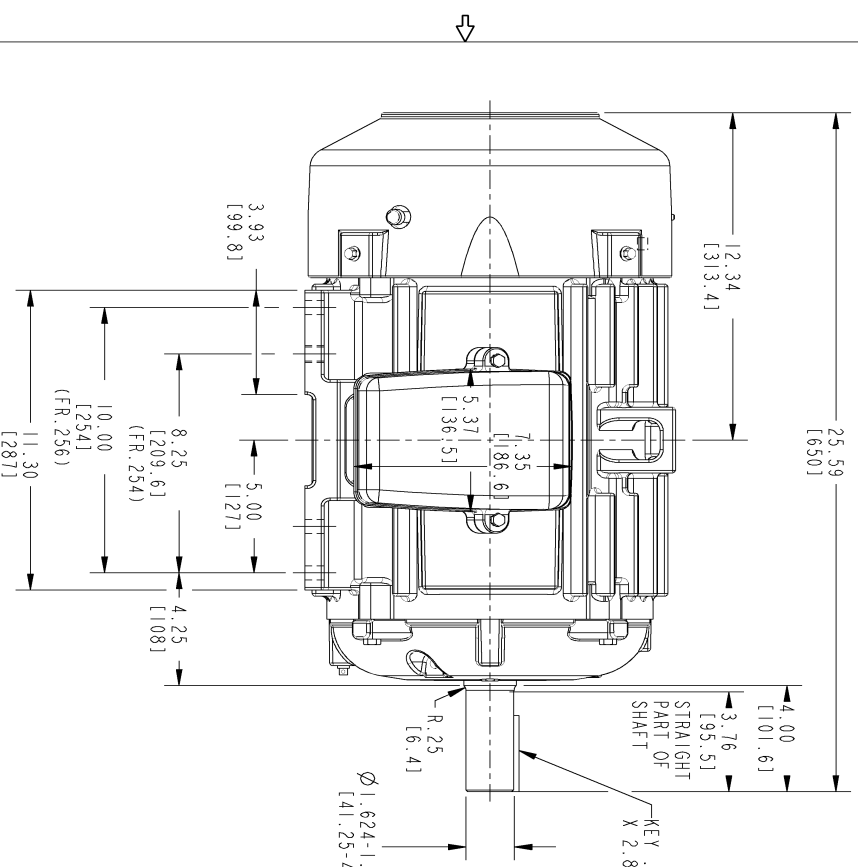

REV.	DESCRIPTION	DATE	APPROVED
1	NOTE X50 ULTRA DELETED	05/20/03	SAJAJAY
2	ISAAC 09-0868	09/29/09	SAVANTHI
3	ISAAC 09-1036	12/02/09	RAGHU
4	ISSAC 12-0025	01/09/11	RAGHU

SIZE DRAWING NO. 4002B5825PAP5201 SH 4 REV

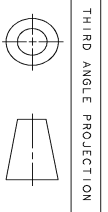

SIGNATURES	DATE
DRMAN GARY WARRNER	JAN 16/02
CHECKED GARY WARRNER	JAN 16/02
ENGRS	
ISSUED GARY WARRNER	169 03/02

APPLIED PRACTICES

SCALE: 0.250 REF. NO: 4002B5825PAP201 SHEET 0F 1

**GE Industrial Systems** GENERAL ELECTRIC COMPANY  
 Fort Wayne, Indiana

**INDUCTION MOTOR OUTLINE**  
 STANDARD CONSTRUCTION  
 FMR: FR250T TEFC

SIZE DRAWING 4002B5825PAP5201 4 REV.

DISTRIBUTION: PMP-18K15

Marks:

**Connection Diagram**  
**GEM2034E-FIG9**



End shield Assembly		
Part Description	DE Side Part#	ODE Side Part#
End Shield	4004D5283PB1	4004D5283SE1
Bearing	235A2607AA01	235A2607AA01
Slinger/Inproseal	149C4399G02	149C4399G02

Fan & Fan Cover Assembly	
Part Description	Part#
Fan	159C6800G01
Fan Cover	4003C5788PA1

Conduit & Accessories Box Assembly	
Part Description	Part#
Conduit Box	4002B5728PA-G04

Mechanical Accessories	
Part Description	Part#
Brake	
Tachometer	