

Product Information Packet

January 12, 2017

Data shown is for the current revision model #. Ensure your nameplate model # matches.

Model Number:	5KS509AAG105A
Catalog Number:	P165
Instruction Manual:	GEI-100351
Connection Diagram:	GEM2034E-FIG2
Outline Drawing:	50DP2104G001DBT

Accessory Connection Diagrams			
Bearing Thermocouple:	None	Heater:	3027JE-1C
RTD:	235A3027XC	Thermistor:	None
Thermostat:	None	Winding Thermocouple:	None
Bearing RTD:	None		

Table of Contents

Specification	01
Performance Characteristics	02
Outline Drawing	03
Connection Drawing(s)	04
Spare parts	05



Marks:

MODEL NUMBER:	5KS509AAG105A	Estimated Weight:	3400 Lbs
Outline Drawing:	50DP2104G001DBT	Time Rating:	CONT
Connection Diagram:	GEM2034E-FIG2	Enclosure:	WPI
Instruction Book:	GEI-100351	Encl Construction:	OPEN
Design Code:	50ED0182E	Ambient Max(°C):	40
Type:	KS	Alt Ambient Max(°C):	XX
Frame:	509LS	Insulation Class:	F
Phases:	3	NEMA Design:	B
Poles:	2	Nominal Efficiency:	94.5 %
Output Power:	450HP 333KW	Guaranteed Efficiency:	93.6
RPM:	3570	3/4 Load Efficiency:	94.5
Voltage:	2300/4000	KVA Code:	G
Hertz:	60	Max KVAR:	69.3
Amps - FL:	98.4/56.6	Power Factor:	90.5
Service Factor:	1.15	Bearing - DE:	6315ZC3
Alt Service Factor:	XX	Bearing - ODE:	6315ZC3

Enclosure is Weather Protected One

Stamped Nameplate Notes:

NEMA ENCLOSURE WP-I, CSA ENCL DP
 GE SELF DECLARED CLASS I DIV 2 MOTOR
 MAX EXPOSED INTERNAL AND EXTERNAL SURFACE
 TEMPERATURES UNDER USUAL SERVICE CONDITION
 AT 1.00 S.F. DO NOT EXCEED 200 DEG C
 VIBRATION LIMIT = 0.150 IN/SEC
 TEMP CONTRL HTR LDS HE1-HE2 115V 200W
 OFFSET CORE - DO NOT ASSEMBLE F2
 MAXIMUM SPACE HEATER SURFACE
 TEMPERATURE 160 DEG C

Additional Information:

2 POLE, LS SHAFT EXTN
 FORMED COIL
 (2)GROUND BOLTS ON FRAME
 TEMP CONTRL 115V HEATER LEADS TO ACC BOX
 100 OHM WINDING RTD LEADS TO ACC BOX
 SUGGESTED WINDING RTD SETTINGS
 ALARM 165C TRIP 175C
 PROVISION FOR BTDS BOTH ENDS
 SUGGESTED BEARING RTD SETTINGS,IF PROVIDED
 ALARM 115C TRIP 125C
 2500 Cu. In. CBOX
 PROVISION FOR JACK SCREWS
 DP-WPI STOCK 09/25/16
 ENGINEER: BAADKARD/BALASUBRAMANIANH

Performance Characteristics

1st Winding 1st Connection

Design: 50ED0182E

Marks:

LOAD %	125.0	115.0	100.0	75.0	50.0	25.0	0.0
% EFF	94.08	94.28	94.69	94.53	93.81	90.37	0.00
% PF	90.01	90.28	92.47	89.44	85.38	70.07	10.3
AMPS	71.49	65.44	55.29	42.97	30.23	19.12	11.11

TORQ(FL)#FT	661.43	TORQ(LR)%FL	151.18	TORQ(BD)%FL	234.74
AMPS(LR)	362.19	PF AT START	0.24		

This motor is capable of two cold or one hot start with a maximum connected load inertia of 616 Lb-Ft Sq (25.93 Kg-meter Sq)at 100% voltage, where the load torque varies with the square of the speed. Acceleration time with maximum inertia and the above load type is 14 seconds. Safe stall time at 100% voltage is 31 seconds cold, 17 seconds hot. Rotor inertia is 75.29 Lb-Ft Sq (3.17 Kg-meter Sq).

Open Circuit A-C:	1.712	Short Circuit D-C:	0.026
Short Circuit A-C:	0.05	X/R Ratio:	9.912
Stator Slots:	48	Rotor Slots:	40

Speed Torque Current Curve (First Connection, First Speed)

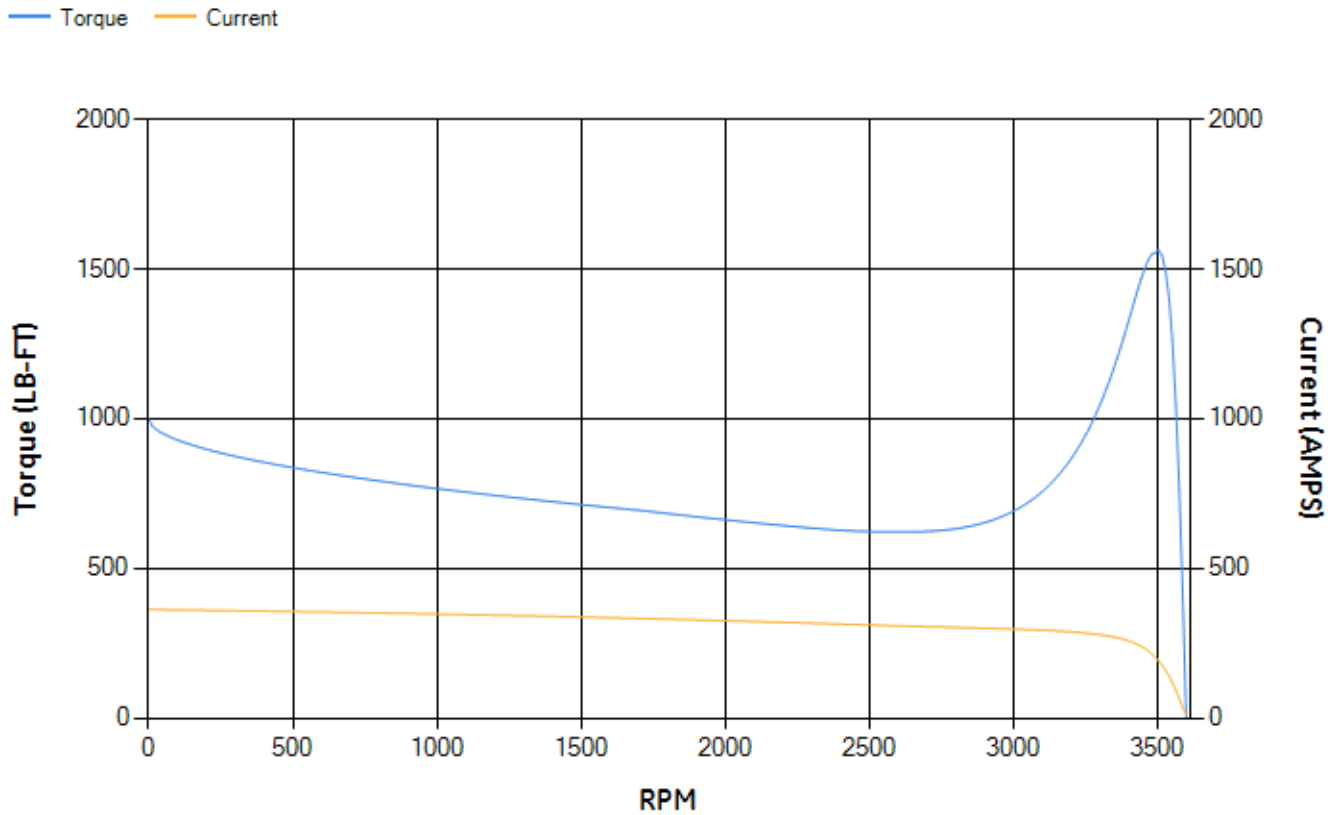

Marks:

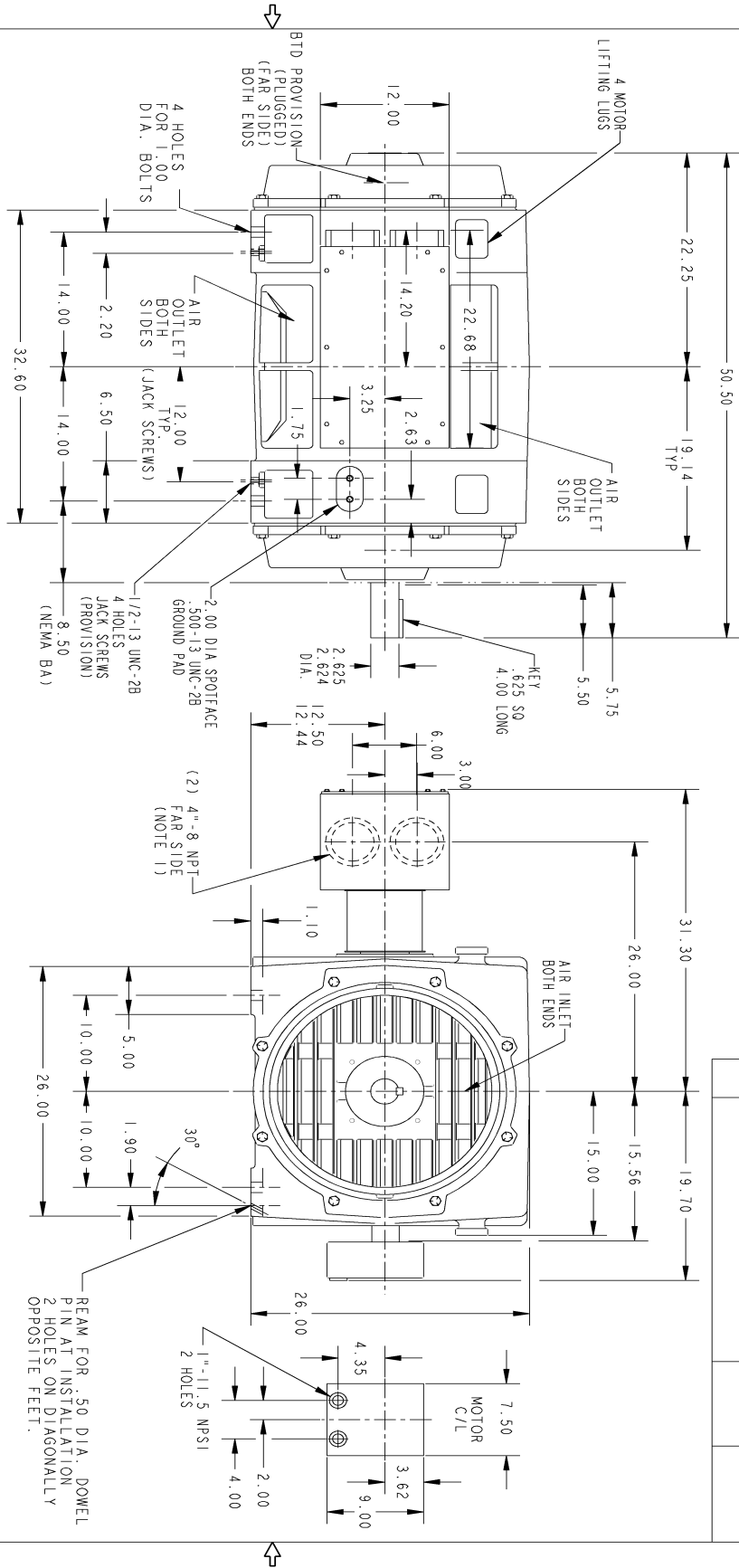

THIRD ANGLE PROJECTION

- NOTES:
- CONDUIT BOX MAY BE TURNED SO THAT ENTRANCE CAN BE MADE UPWARDS, DOWNWARDS, OR FROM EITHER SIDE. WHEN DOWNWARDS, ENTRANCE IS BELOW THE FEET.
 - F1 ASSEMBLY AS SHOWN. F2 ASSEMBLY HAS CONDUIT BOXES ON OPPOSITE SIDES.

SIZE	DRAWING NO.	REV	SHEET
B	50DP2104G001DBT	0	1

REV.	DESCRIPTION	DATE	APPROVED

SIGNATURES		DATE	 GENERAL ELECTRIC COMPANY
MODEL	LAXMIKANTH	09/29/16	
DETAIL	HAREHARAN	09/29/16	OUTLINE 509L5 -DP, 2500 CU IN C/BOX, GROUND PAD ACC BOX, JACK SCREWS PROV., BRG RTD/T/C PROV
ENGR	HAREHARAN	09/29/16	
QC			
QUALITY	LAXMIKANTH	09/29/16	REV
ISSUED			0
SOLD MODEL	MODEL NAME	SCALE: .10	REF. NO.: 50DP2104G001DTC
			SHEET 1 of 1

Marks:

Connection Diagram
GEM2034E-FIG2

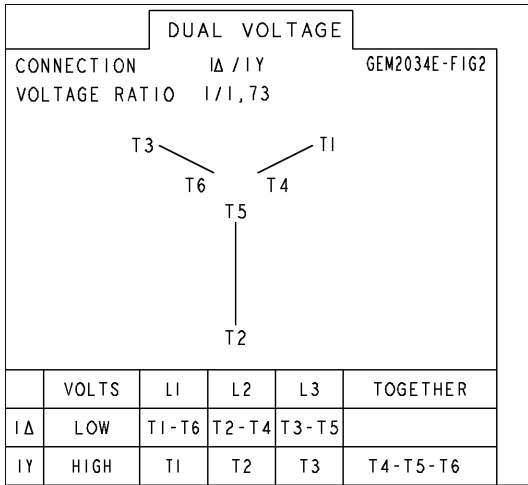

Heater Connection
3027JE-1C

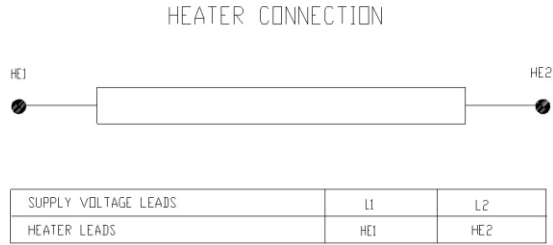

SHEET 0
REV 0
235A3027XC
A
SIZE DRAWING NO.

GE PROPRIETARY INFORMATION
This document is the property of General Electric Company ("GE") and contains proprietary information of GE. This document is loaned on the express condition that neither it nor the information contained therein shall be disclosed to others without the express written consent of GE Industrial Systems, and that the information shall be used by the recipient only as approved expressly by GE Industrial Systems. This document shall be returned to GE upon its request. This document may be subject to certain restrictions under U.S. export control laws and regulations.

REVISIONS			
REV.	DESCRIPTION	DATE	APPROVED

THIRD ANGLE PROJECTION

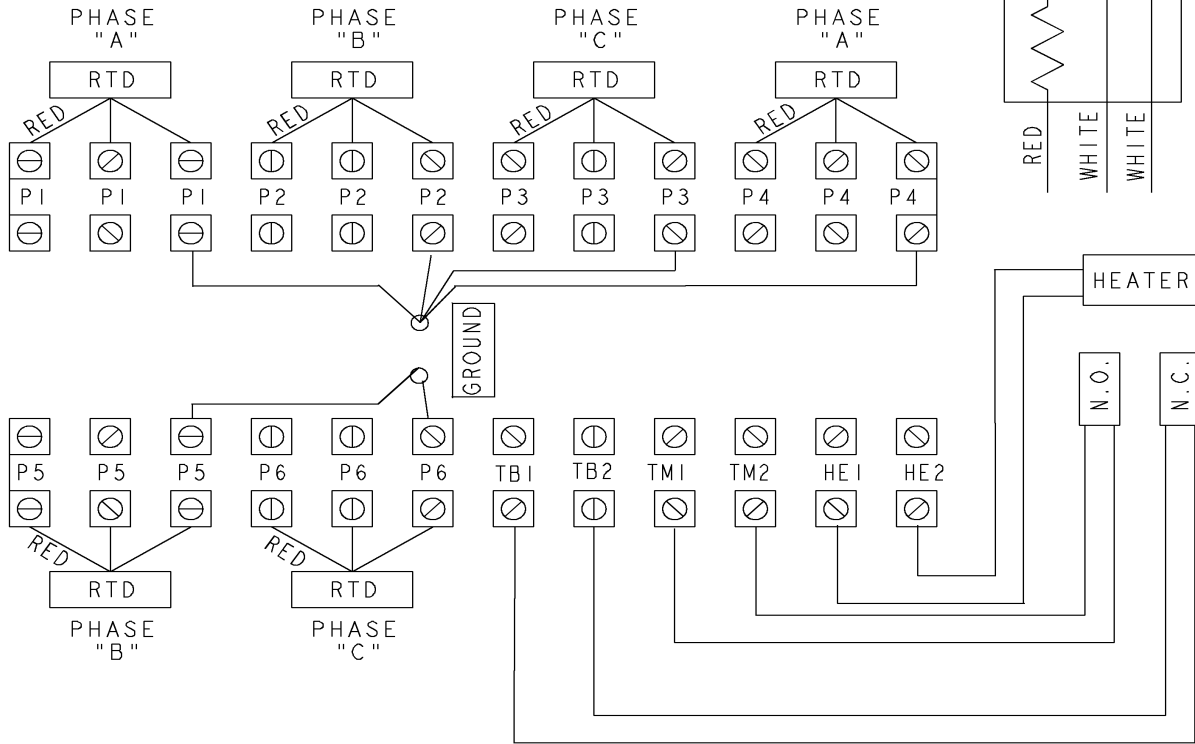
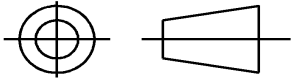

- NOTE 1: TERMINAL LABELS ARE PROVIDED FOR ACCESSORIES THAT MAY OR MAY NOT BE INCLUDED WITH THE MOTOR.
- NOTE 2: SPARE RTDS (P7 & P8) FURNISHED IN CASE OF FAILURE IN OTHER RTDS (P1-P6). PHASE LOCATION WILL DEPEND UPON NUMBER OF POLES WINDING CONFIGURATION.
- NOTE 3: IT IS RECOMMENDED THAT RTDS BE GROUND AT EITHER THE MACHINE OR CONNECTED TO A GROUND CONTROL CIRCUIT. FOR PROPER OPERATION DO NOT GROUND AT THE MACHINE IF CONNECTED TO A GROUND CIRCUIT AT THE CONTROL.

Part must conform to SI 900000 Sect. 4, Toxicity Procedure

FOR ADDITIONAL INFO REFER TO:	SIGNATURES	DATE
APPLIED PRACTICES		
DIMENSIONS ARE IN INCHES		
TOLERANCE ON:		
1 PL DECIMALS ± 0.1		
2 PL DECIMALS ± 0.02		
3 PL DECIMALS ± 0.005		
ANGLES ± 0.5		
FRACTIONS ±		
FINISH ✓		
MATERIAL	SOLID MODEL: MODEL NAME	

GE Motors GENERAL ELECTRIC COMPANY

TITLE: **CONNECTION DIAGRAM**
IEC
WINDING RTD'S & T'STATS & HEATERS

SIZE DRAWING: A
235A3027XC
REV 0

SCALE: NA
SHEET 1 of 1

End shield Assembly		
Part Description	DE Side Part#	ODE Side Part#
End Shield	119D1853NA1	119D1853AW1
Bearing	235A2513AG01	235A2513AG01
Slinger/Inproseal	235A2300FP2	

Fan & Fan Cover Assembly	
Part Description	Part#
Fan	
Fan Cover	

Conduit & Accessories Box Assembly	
Part Description	Part#
Conduit Box	179B9025G01

Mechanical Accessories	
Part Description	Part#
Brake	
Tachometer	

