

# Product Information Packet

November 9, 2016

Data shown is for the current revision model #. Ensure your nameplate model # matches.

<b>Model Number:</b>	<b>5KS213SAA108D1</b>
<b>Catalog Number:</b>	<b>M990</b>
<b>Instruction Manual:</b>	GEI-56128
<b>Connection Diagram:</b>	GEM2034E-FIG1
<b>Outline Drawing:</b>	4002B5821PAP5201

## Accessory Connection Diagrams

<b>Bearing Thermocouple:</b>	None	<b>Heater:</b>	None
<b>RTD:</b>	None	<b>Thermistor:</b>	None
<b>Thermostat:</b>	None	<b>Winding Thermocouple:</b>	None
<b>Bearing RTD:</b>	None		

## Table of Contents

Specification	01
Performance Characteristics	02
Outline Drawing	03
Connection Drawing(s)	04
Spare parts	05



**Marks:**

<b>MODEL NUMBER:</b>	<b>5KS213SAA108D1</b>	<b>Estimated Weight:</b>	200 Lbs
<b>Outline Drawing:</b>	4002B5821PAP5201	<b>Time Rating:</b>	CONT
<b>Connection Diagram:</b>	GEM2034E-FIG1	<b>Enclosure:</b>	TEFC
<b>Instruction Book:</b>	GEI-56128	<b>Encl Construction:</b>	X\$D
<b>Design Code:</b>	21BD0074AA	<b>Ambient Max(°C):</b>	40
<b>Type:</b>	KS	<b>Alt Ambient Max(°C):</b>	65
<b>Frame:</b>	213T	<b>Insulation Class:</b>	H
<b>Phases:</b>	3	<b>NEMA Design:</b>	B
<b>Poles:</b>	2	<b>Nominal Efficiency:</b>	89.5 %
<b>Output Power:</b>	7.5HP 5.6KW	<b>Guaranteed Efficiency:</b>	88.5
<b>RPM:</b>	3530	<b>3/4 Load Efficiency:</b>	90.1
<b>Voltage:</b>	460	<b>KVA Code:</b>	H
<b>Hertz:</b>	60	<b>Max KVAR:</b>	2.1
<b>Amps - FL:</b>	9.0	<b>Power Factor:</b>	87.5
<b>Service Factor:</b>	1.25	<b>Bearing - DE:</b>	6208ZC3
<b>Alt Service Factor:</b>	1.00	<b>Bearing - ODE:</b>	6208ZC3

**Enclosure is Totally Enclosed Fan-Cooled**

---

**Stamped Nameplate Notes:**

SF AMPS 11.2  
 STAMP NP249A5564P051 AS BELOW:  
 MODEL:5KS213SAA108D1 S/N: XXX  
 CSA CERTIFIED CSA09.2216219 FOR EX NA IIC 200C GC  
 CL 1 ZONE2 AEX NA IIC 200C;CL 1 DIV2 GRP ABCD 200C  
 IN -40C <= AMB <= 40C, 1.0 SF ON SINE-WAVE PWR  
 SURF TEMP 215C AT 1.25SF ON SINE-WAVE PWR  
 OR 200C VT OR 200C CT OR 200C CHP PWM CONTROL  
 ALTERNATE RATING FOR PWM CONTROL 1.0SF 40C AMB  
 VT 0 - 60 HZ, CT 3-60 HZ, CHP 60-90 HZ.

**Additional Information:**

2P - T EXTN  
 STANDARD FLOOR MOUNT  
 C/BOX 55 CU IN-1.00 NPT  
 F1 CONDUIT BOX MOUNTING  
 OIL RESISTANT SLEEVING ON LEADS

**Performance Characteristics**

1st Winding 1st Connection

**Design: 21BD0074AA**

**Marks:**

LOAD %	125.0	115.0	100.0	75.0	50.0	25.0	0.0
% EFF	88.42	88.94	89.78	90.1	89.36	84.45	0.00
% PF	88.62	88.37	87.57	84.47	76.7	56.43	9.41
AMPS	11.2	10.27	8.92	6.92	5.12	3.68	2.93

TORQ(FL)#FT	11.16	TORQ(LR)%FL	192.83	TORQ(BD)%FL	292.52
AMPS(LR)	57.09	PF AT START	0.36		

This motor is capable of two cold or one hot start with a maximum connected load inertia of 78 Lb-Ft Sq (3.28 Kg-meter Sq) at 100% voltage, where the load torque varies with the square of the speed. Acceleration time with maximum inertia and the above load type is 49 seconds. Safe stall time at 100% voltage is 85 seconds cold, 59 seconds hot. Rotor inertia is 0.31 Lb-Ft Sq (0.01 Kg-meter Sq).

Open Circuit A-C:	0.406	Short Circuit D-C:	0.01
Short Circuit A-C:	0.018	X/R Ratio:	3.858
Stator Slots:	36	Rotor Slots:	26

**Speed Torque Current Curve (First Connection, First Speed)**

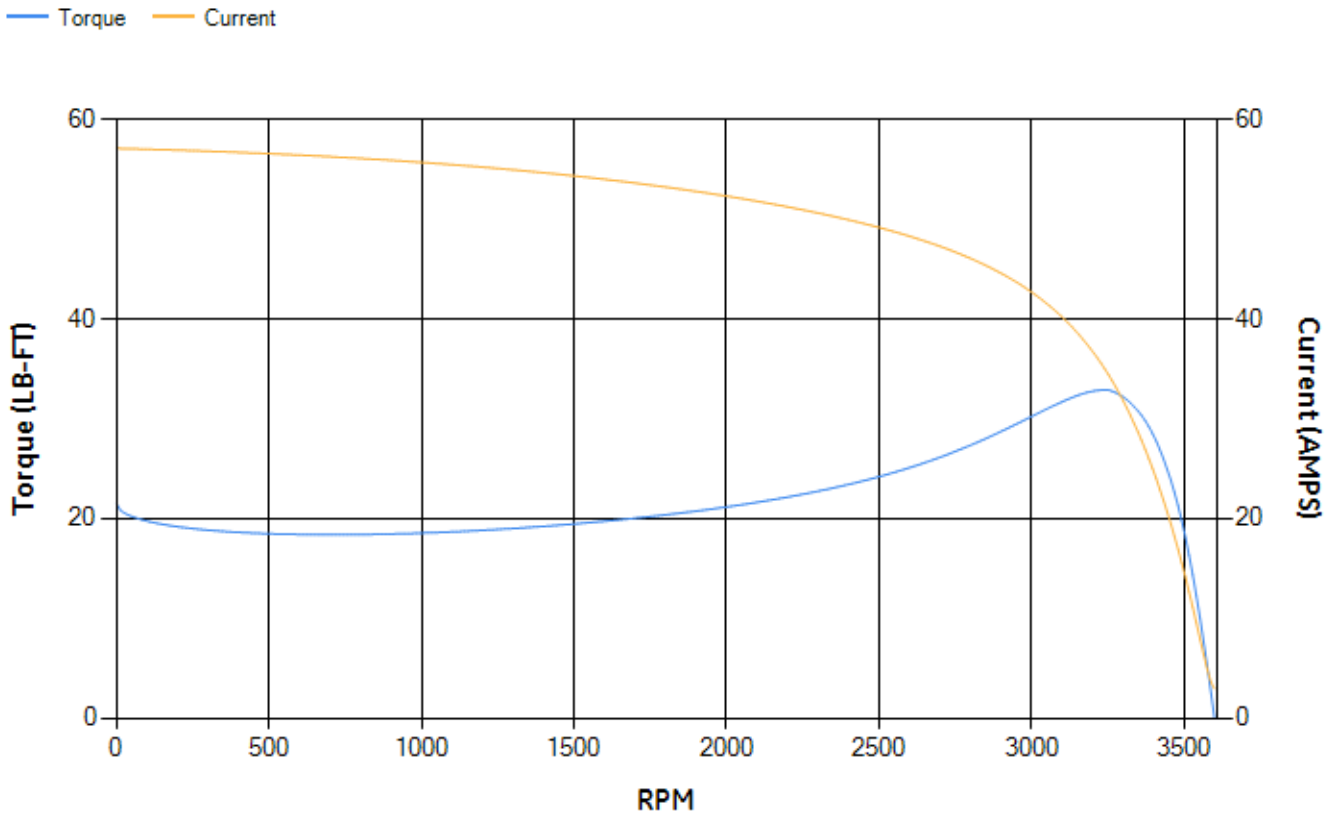

Marks:

NOTE 1: CONDUIT BOX MAY BE ASSEMBLED WITH ENTRANCE UP, DOWN OR TO EITHER SIDE.  
 NOTE 2: F1 ASSEMBLY AS SHOWN. F2 ASSEMBLY CONDUIT BOX ON OPPOSITE SIDE FROM SHOWN LOCATION.

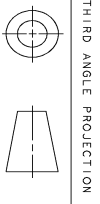
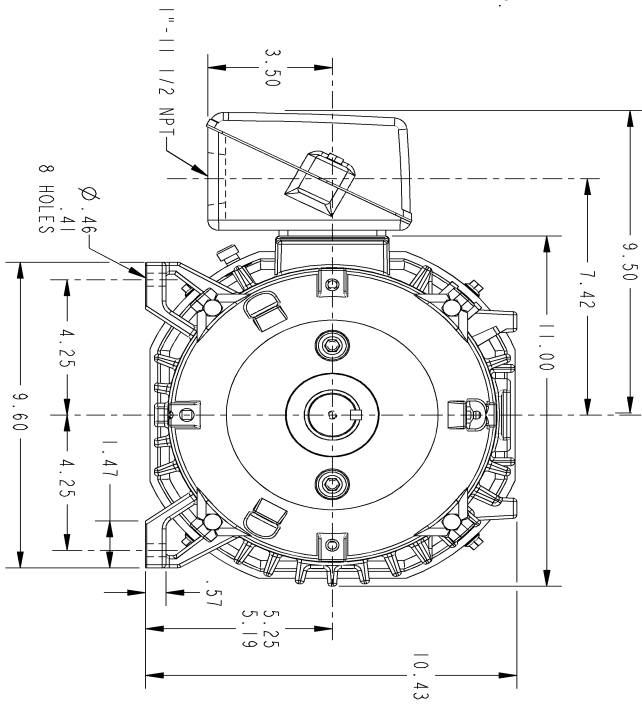
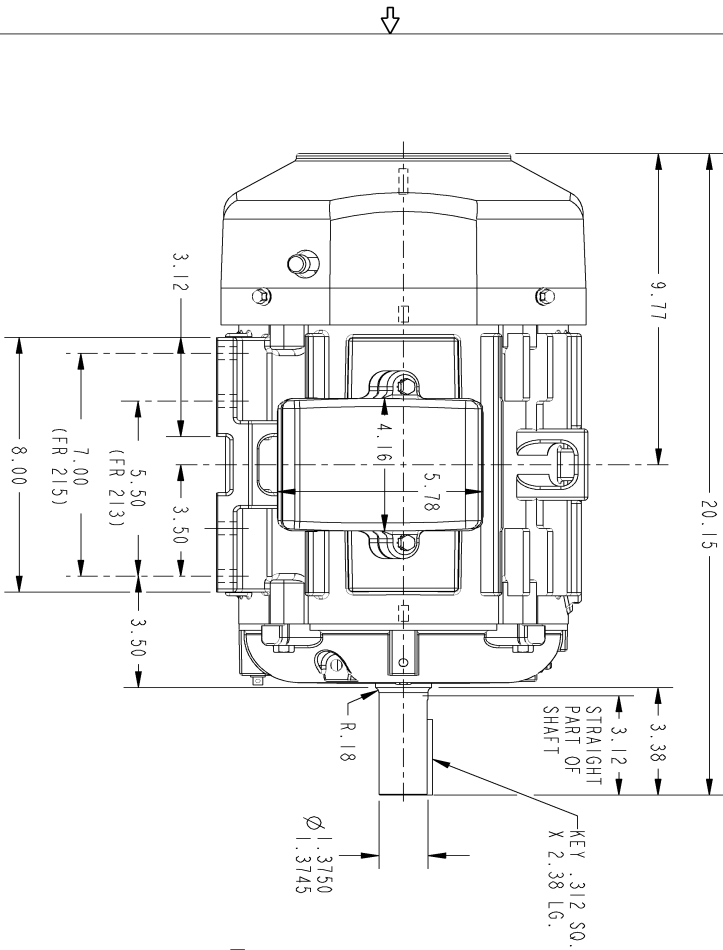

THIRD ANGLE PROJECTION

SIZE B DRAWING NO. 4002B5821PAP5201 SH 1 REV 1

REVISIONS			
REV.	DESCRIPTION	DATE	APPROVED
1	ISAAC #15-0018 PRASANNA	08/01/2015	ADI

SIGNATURES	DATE	<b>GE Industrial Systems</b> GENERAL ELECTRIC COMPANY Fort Wayne, Indiana	
DESIGN: GARY WARRNER	JAN 22/02	<b>INDUCTION MOTOR OUTLINE</b> STANDARD CONSTRUCTION FME: FR213/25T TFC	
CHECKED: GARY WARRNER	FEB 09/02		
ENGR: GARY WARRNER	SEP 03/02		
ISSUED: GARY WARRNER	SEP 03/02		
APPLIED PRACTICES		SIZE DRAWING	REV.
		B	1
SCALE: 0.300		REF. NO: 4002B5821PAP201	SHEET 1 OF 1

DISTRIBUTION: PMP-1BK15

Marks:

**Connection Diagram**  
**GEM2034E-FIG1**

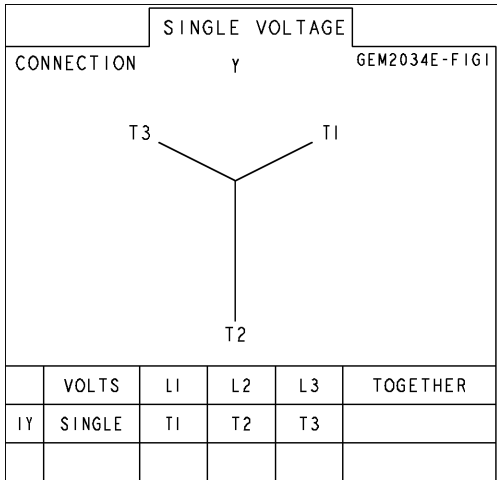

End shield Assembly		
Part Description	DE Side Part#	ODE Side Part#
End Shield	4004D5282PB1	4004D5282SJ1
Bearing	235A2603AA01	235A2603AA01
Slinger/Inproseal	149C4399G01	149C4399G01

Fan & Fan Cover Assembly	
Part Description	Part#
Fan	159C6704G01
Fan Cover	4003C5787PA1

Conduit & Accessories Box Assembly	
Part Description	Part#
Conduit Box	4002B5721PA-G01

Mechanical Accessories	
Part Description	Part#
Brake	
Tachometer	