

ROTATION  
UNITS  
BI-DIRECTIONAL  
SEE NOTE 5

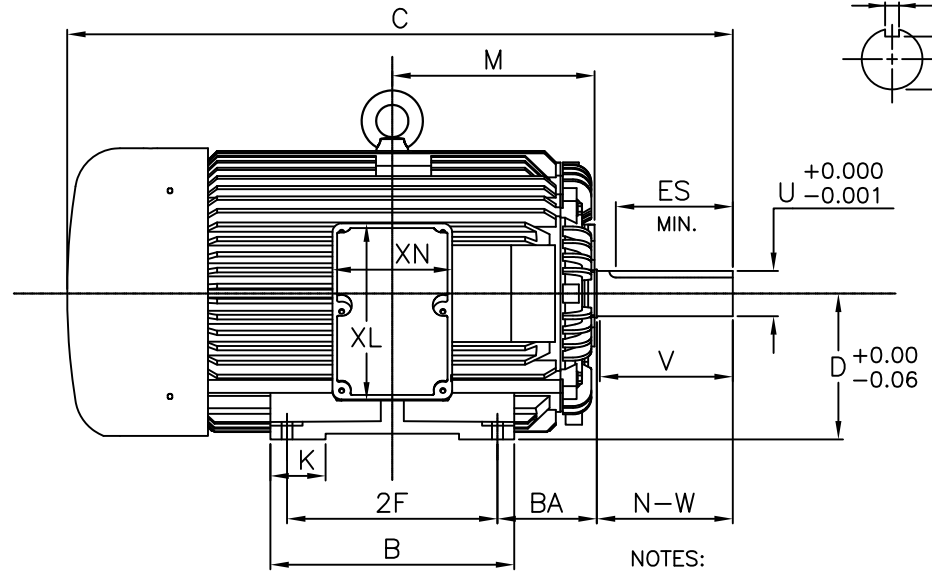
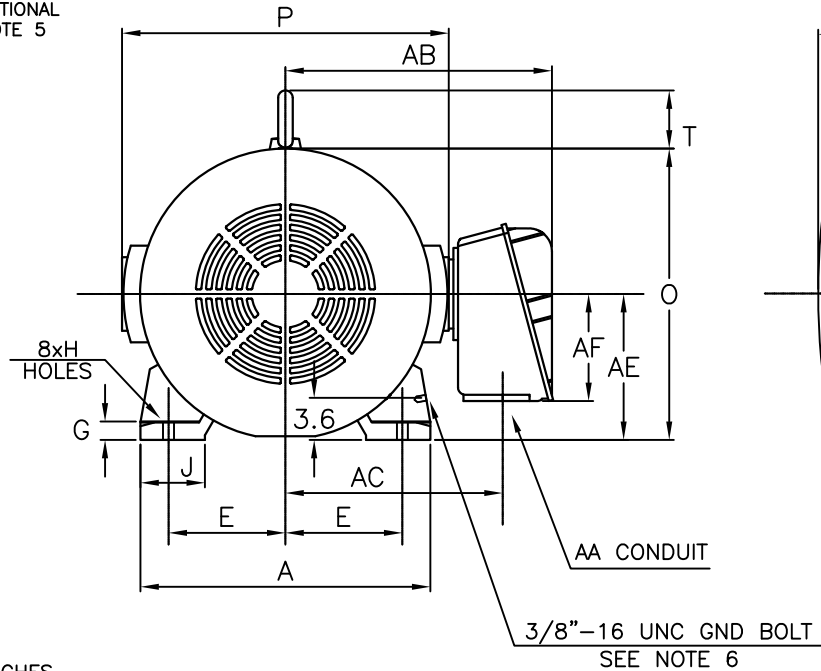

NOTES:

1. DIMENSION V REPRESENTS LENGTH OF STRAIGHT PART OF SHAFT
2. MAIN CONDUIT BOX MAY BE ROTATED IIN 90° INCREMENTS
3. KEY DIMENSIONS EQUAL S x S x 10.00 FOR UZ AND S x S x 3.00 FOR US (MOTOR SUPPLIED WITH KEY)
4. MOTOR WEIGHT SHOWN IS MAXIMUM HORSEPOWER IN FRAME
5. STANDARD PRODUCT USE BI-DIRECTIONAL FAN. OPPOSITE ROTATION AVAILABLE ONLY BY CONNECTION CHANGE
6. FRAME GROUND BOLT STANDARD ON 841 PRODUCT

UNITS: INCHES

FRAME SIZE	MOTOR DIMENSIONS											CONDUIT BOX						
	A	B	C	D	G	J	K	M	O	P	T	AA[NPT]	AB	AC	AE	AF	XL	XN
505US	24.9	20.9	50.2	12.50	1.5	5.6	4.8	17.3	24.7	28.0	5.2	4.00	22.9	18.6	12.5	9.2	15.2	10.2
505UZ	24.9	20.9	57.0	12.50	1.5	5.6	4.8	17.3	24.7	28.0	5.2	4.00	22.9	18.6	12.5	9.2	15.2	10.2

FRAME SIZE	MOUNTING				SHAFT EXTENSION			KEY SEAT			BEARINGS		MAXIMUM WEIGHT
	E	2F	H	BA	N-W	V	U	R	S	ES	LS	OS	
505US	10.00	18.00	0.94	8.5	4.75	4.50	2.875	2.450	0.750	3.00	6318C3	6318C3	4089 lbs.
505UZ	10.00	18.00	0.94	8.5	11.62	11.38	3.875	3.309	1.000	10.00	NU322C3	6318C3	4089 lbs.

CUSTOMER: \_\_\_\_\_ MOTOR MODEL NO.: \_\_\_\_\_  
P.O. NO.: \_\_\_\_\_ HP: \_\_\_\_\_ VOLTAGE: \_\_\_\_\_ RPM(SYN.): \_\_\_\_\_ Hz: \_\_\_\_\_  
FRAME SIZE: \_\_\_\_\_ PRODUCT TYPE: EQP III 840 & 841  
COMMENTS: \_\_\_\_\_

TAG NO's.: \_\_\_\_\_

PER: \_\_\_\_\_ DATE: \_\_\_\_\_

- STANDARD (NO AUX. BOXES)
- RTD AUX. BOX
- SPACE HEATER AUX. BOX
- BEARING RTD's

TOSHIBA RESERVES THE RIGHT TO MAKE CHANGES OF TECHNICAL IMPROVEMENT AND THE DATA MAY CHANGE WITHOUT NOTICE  PRELIMINARY

DO NOT USE FOR CONSTRUCTION, INSTALLATION, OR APPLICATION PURPOSES UNLESS THE DRAWING IS MARKED AS CERTIFIED  CERTIFIED

**TOSHIBA**

TOSHIBA INTERNATIONAL CORPORATION

TOTALLY-ENCLOSED FAN-COOLED  
HORIZONTAL FOOT-MOUNTED  
3 PHASE INDUCTION MOTOR  
F1 ASSEMBLY

**XT SERIES**

VISIT OUR WEBSITE AT:  
www.toshiba.com/ind