

Product Information Packet

January 12, 2017

Data shown is for the current revision model #. Ensure your nameplate model # matches.

Model Number:	5KS513EAG306A
Catalog Number:	P476
Instruction Manual:	GEI-100351
Connection Diagram:	GEM2034E-FIG2
Outline Drawing:	50DP4187G004DBV

Accessory Connection Diagrams			
Bearing Thermocouple:	None	Heater:	3027JE-1C
RTD:	235A3027XC	Thermistor:	None
Thermostat:	None	Winding Thermocouple:	None
Bearing RTD:	None		

Table of Contents

Specification	01
Performance Characteristics	02
Outline Drawing	03
Connection Drawing(s)	04
Spare parts	05



Marks:

MODEL NUMBER:	5KS513EAG306A	Estimated Weight:	5620 Lbs
Outline Drawing:	50DP4187G004DBV	Time Rating:	CONT
Connection Diagram:	GEM2034E-FIG2	Enclosure:	WP11
Instruction Book:	GEI-100351	Encl Construction:	OPEN
Design Code:	50ED3140EA	Ambient Max(°C):	40
Type:	KS	Alt Ambient Max(°C):	XX
Frame:	5013S	Insulation Class:	F
Phases:	3	NEMA Design:	-
Poles:	6	Nominal Efficiency:	95.4 %
Output Power:	700HP 518KW	Guaranteed Efficiency:	94.5
RPM:	1190	3/4 Load Efficiency:	96.3
Voltage:	2300/4000	KVA Code:	G
Hertz:	60	Max KVAR:	259.2
Amps - FL:	175.6/101.0	Power Factor:	78.5
Service Factor:	1.15	Bearing - DE:	SLEEVE
Alt Service Factor:	XX	Bearing - ODE:	SLEEVE

Enclosure is Weather Protected Two

Stamped Nameplate Notes:

NEMA ENCLOSURE WP-II, CSA ENCL DP
 GE SELF DECLARED CLASS I DIV 2 MOTOR
 MAX EXPOSED INTERNAL AND EXTERNAL SURFACE
 TEMPERATURES UNDER USUAL SERVICE CONDITION
 AT 1.00 S.F. DO NOT EXCEED 200 DEG C
 VIBRATION LIMIT = 0.150 IN/SEC
 TEMP CONTRL HTR LDS HE1-HE2 115V 200W
 MAXIMUM SPACE HEATER SURFACE
 TEMPERATURE 160 DEG C

Additional Information:

6 POLE, S SHAFT EXTN
 FORMED COIL
 SLEEVE BEARINGS
 (2)GROUND BOLTS ON FRAME
 TEMP CONTRL 115V HEATER LEADS TO ACC BOX
 100 OHM WINDING RTD LEADS TO ACC BOX
 SUGGESTED WINDING RTD SETTINGS
 ALARM 165C TRIP 175C
 BEARING RTD PROVISION AT BOTH END(PLUGGED)
 SUGGESTED BEARING RTD SETTINGS,IF PROVIDED
 ALARM 90C TRIP 100C
 2500 Cu. In. CBOX
 PROVISION FOR JACK SCREWS
 DP-WP11 STOCK 09/30/16
 ENGINEER : NANCHARAIAH/NATH T

Performance Characteristics

1st Winding 1st Connection

Design: 50ED3140EA

Marks:

LOAD %	125.0	115.0	100.0	75.0	50.0	25.0	0.0
% EFF	95.57	95.78	96.24	96.28	96.07	94.24	0.00
% PF	80.52	79.94	79.88	73.44	62.66	40.31	2.18
AMPS	122.38	113.17	97.87	79.92	62.58	49.58	41.57

TORQ(FL)#FT	3092.88	TORQ(LR)%FL	112.09	TORQ(BD)%FL	260.72
AMPS(LR)	605.59	PF AT START	0.21		

This motor is capable of two cold or one hot start with a maximum connected load inertia of 13238 Lb-Ft Sq (557.32 Kg-meter Sq) at 100% voltage, where the load torque varies with the square of the speed. Acceleration time with maximum inertia and the above load type is 16 seconds. Safe stall time at 100% voltage is 73 seconds cold, 32 seconds hot. Rotor inertia is 254 Lb-Ft Sq (10.69 Kg-meter Sq).

Open Circuit A-C:	0.599	Short Circuit D-C:	0.032
Short Circuit A-C:	0.038	X/R Ratio:	12.211
Stator Slots:	72	Rotor Slots:	58

Speed Torque Current Curve (First Connection, First Speed)

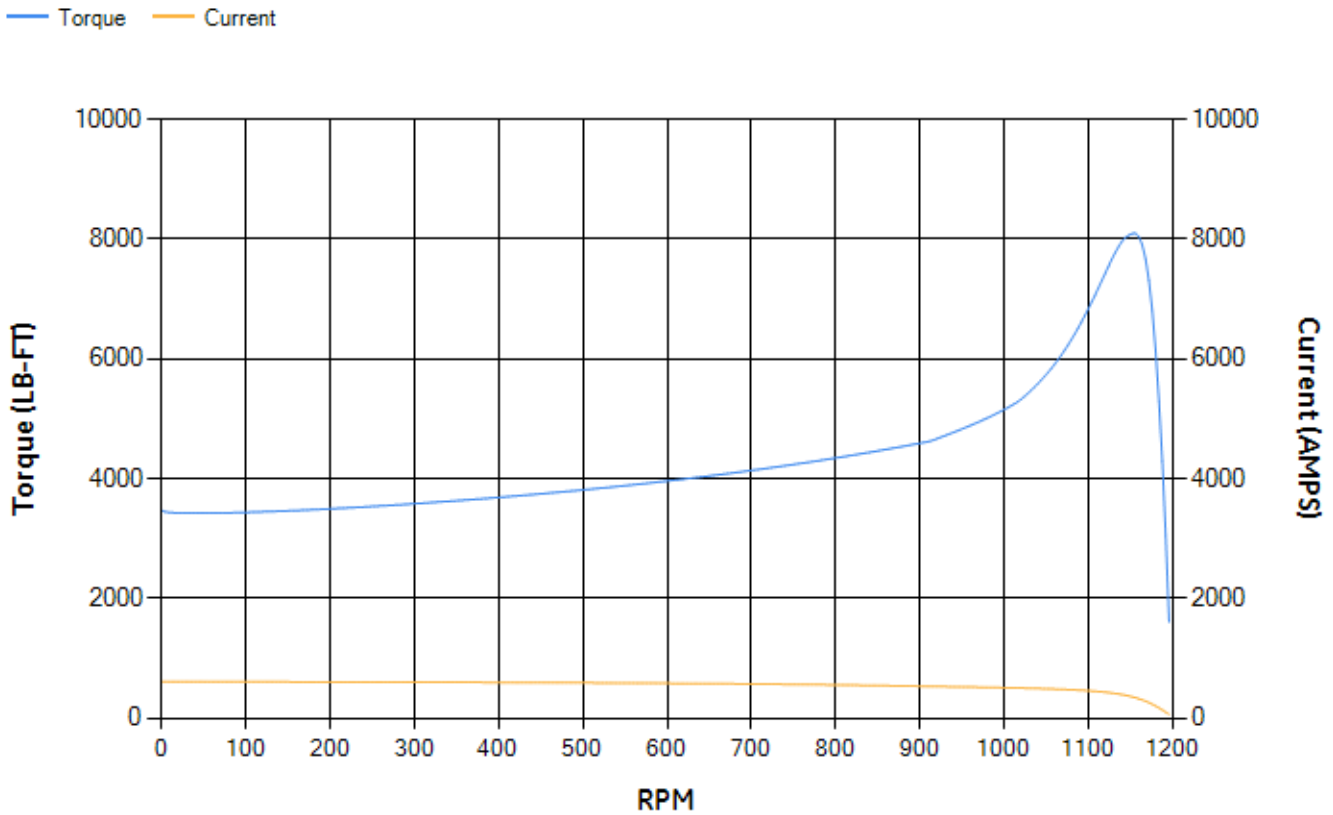

Marks:

Connection Diagram
GEM2034E-FIG2

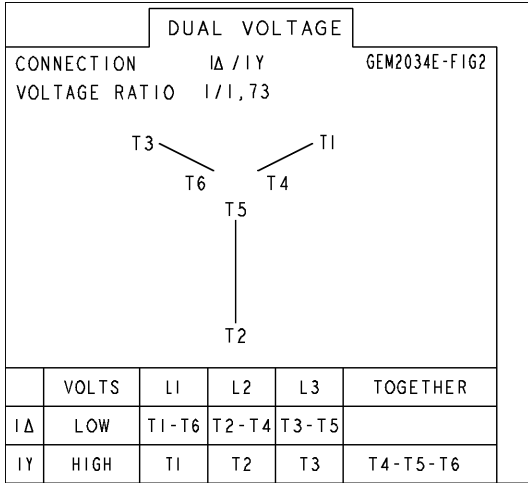

Heater Connection
3027JE-1C



SHEET 0
REV 0
235A3027XC
A
SIZE DRAWING NO.

GE PROPRIETARY INFORMATION
This document is the property of General Electric Company ("GE") and contains proprietary information of GE. This document is loaned on the express condition that neither it nor the information contained therein shall be disclosed to others without the express written consent of GE Industrial Systems, and that the information shall be used by the recipient only as approved expressly by GE Industrial Systems. This document shall be returned to GE upon its request. This document may be subject to certain restrictions under U.S. export control laws and regulations.

REVISIONS			
REV.	DESCRIPTION	DATE	APPROVED

THIRD ANGLE PROJECTION

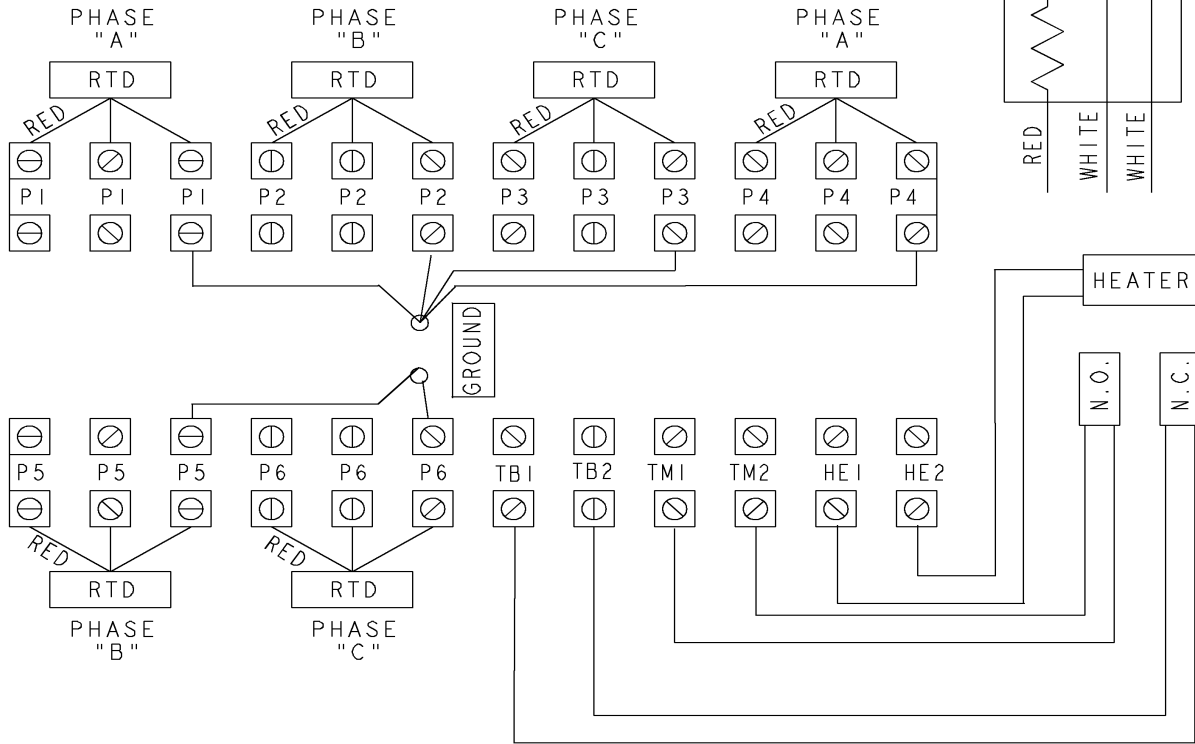

- NOTE 1: TERMINAL LABELS ARE PROVIDED FOR ACCESSORIES THAT MAY OR MAY NOT BE INCLUDED WITH THE MOTOR.
- NOTE 2: SPARE RTDS (P7 & P8) FURNISHED IN CASE OF FAILURE IN OTHER RTDS (P1-P6). PHASE LOCATION WILL DEPEND UPON NUMBER OF POLES WINDING CONFIGURATION.
- NOTE 3: IT IS RECOMMENDED THAT RTDS BE GROUNDED AT EITHER THE MACHINE OR CONNECTED TO A GROUNDED CONTROL CIRCUIT. FOR PROPER OPERATION DO NOT GROUND AT THE MACHINE IF CONNECTED TO A GROUND CIRCUIT AT THE CONTROL.

Part must conform to SI 900000 Sect. 4, Toxicity Procedure

FOR ADDITIONAL INFO REFER TO:	SIGNATURES	DATE
APPLIED PRACTICES	MODEL	
DIMENSIONS ARE IN INCHES	DETAIL VIVEK	01/08/15
TOLERANCE ON:	CHECKED KARTHIK	01/08/15
1 PL DECIMALS ± 0.1	ENGRG	
2 PL DECIMALS ± 0.02	MFG	
3 PL DECIMALS ± 0.005	QUALITY	
ANGLES ± 0.5	ISSUED VIVEK	01/08/15
FRACTIONS ±		
FINISH ✓		
MATERIAL	SOLID MODEL: MODEL NAME	

GE Motors GENERAL ELECTRIC COMPANY

TITLE: **CONNECTION DIAGRAM**
IEC
WINDING RTD'S & T'STATS & HEATERS

SIZE DRAWING: A
235A3027XC
REV 0

SCALE: NA
SHEET 1 of 1

End shield Assembly		
Part Description	DE Side Part#	ODE Side Part#
End Shield	119D1878DB2	119D1878DM1
Bearing	153B4435AD-G01	153B4435AD-G01
Slinger/Inproseal		

Fan & Fan Cover Assembly	
Part Description	Part#
Fan	
Fan Cover	

Conduit & Accessories Box Assembly	
Part Description	Part#
Conduit Box	179B9025G01

Mechanical Accessories	
Part Description	Part#
Brake	
Tachometer	

