

Product Information Packet

November 8, 2016

Data shown is for the current revision model #. Ensure your nameplate model # matches.

| | |
|----------------------------|-----------------------|
| Model Number: | 5KS215SAA205D1 |
| Catalog Number: | M9148 |
| Instruction Manual: | GEI-56128 |
| Connection Diagram: | GEM2034E-FIG9 |
| Outline Drawing: | 4002B5821PAP5201 |

| Accessory Connection Diagrams | | | |
|-------------------------------|------|------------------------------|------|
| Bearing Thermocouple: | None | Heater: | None |
| RTD: | None | Thermistor: | None |
| Thermostat: | None | Winding Thermocouple: | None |
| Bearing RTD: | None | | |

Table of Contents

| | |
|-----------------------------|----|
| Specification | 01 |
| Performance Characteristics | 02 |
| Outline Drawing | 03 |
| Connection Drawing(s) | 04 |
| Spare parts | 05 |



Marks:

| | | | |
|----------------------------|-----------------------|-------------------------------|---------|
| MODEL NUMBER: | 5KS215SAA205D1 | Estimated Weight: | 220 Lbs |
| Outline Drawing: | 4002B5821PAP5201 | Time Rating: | CONT |
| Connection Diagram: | GEM2034E-FIG9 | Enclosure: | TEFC |
| Instruction Book: | GEI-56128 | Encl Construction: | X\$D |
| Design Code: | 21BD1134A | Ambient Max(°C): | 40 |
| Type: | KS | Alt Ambient Max(°C): | 65 |
| Frame: | 215T | Insulation Class: | H |
| Phases: | 3 | NEMA Design: | B |
| Poles: | 4 | Nominal Efficiency: | 91.7 % |
| Output Power: | 10HP 7.4KW | Guaranteed Efficiency: | 91.0 |
| RPM: | 1765 | 3/4 Load Efficiency: | 92.3 |
| Voltage: | 230/460 | KVA Code: | H |
| Hertz: | 60 | Max KVAR: | 3.0 |
| Amps - FL: | 24.4/12.2 | Power Factor: | 83.5 |
| Service Factor: | 1.25 | Bearing - DE: | 6208ZC3 |
| Alt Service Factor: | 1.00 | Bearing - ODE: | 6208ZC3 |

Enclosure is Totally Enclosed Fan-Cooled

Stamped Nameplate Notes:

SF AMPS 30.7/15.4
 STAMP NP249A5564P051 AS BELOW:
 MODEL:5KS215SAA205D1 S/N: XXX
 CSA CERTIFIED CSA09.2216219 FOR EX NA IIC 200C GC
 CL 1 ZONE2 AEX NA IIC 200C;CL 1 DIV2 GRP ABCD 200C
 IN -40C <= AMB <= 40C, 1.0 SF ON SINE-WAVE PWR
 SURF TEMP 200C AT 1.25SF ON SINE-WAVE PWR
 OR 200C VT OR 215C CT OR 200C CHP PWM CONTROL
 ALTERNATE RATING FOR PWM CONTROL 1.0SF 40C AMB
 VT 0 - 60 HZ, CT 3-60 HZ, CHP 60-90 HZ.

Additional Information:

4P - T EXTN
 STANDARD FLOOR MOUNT
 C/BOX 55 CU IN-1.00 NPT
 F1 CONDUIT BOX MOUNTING
 OIL RESISTANT SLEEVING ON LEADS



Performance Characteristics

1st Winding 1st Connection

Design: 21BD1134A

Marks:

| LOAD % | 125.0 | 115.0 | 100.0 | 75.0 | 50.0 | 25.0 | 0.0 |
|--------|-------|-------|-------|-------|-------|-------|------|
| % EFF | 90.28 | 90.86 | 91.78 | 92.33 | 92.15 | 88.91 | 0.00 |
| % PF | 84.32 | 84.28 | 83.68 | 80.6 | 72.42 | 51.52 | 5.88 |
| AMPS | 15.37 | 14.06 | 12.19 | 9.43 | 7.01 | 5.11 | 4.17 |

| | | | | | |
|--------------------|-------|--------------------|--------|--------------------|--------|
| TORQ(FL)#FT | 29.72 | TORQ(LR)%FL | 190.93 | TORQ(BD)%FL | 273.62 |
| AMPS(LR) | 79.12 | PF AT START | 0.4 | | |

This motor is capable of two cold or one hot start with a maximum connected load inertia of 338 Lb-Ft Sq (14.23 Kg-meter Sq) at 100% voltage, where the load torque varies with the square of the speed. Acceleration time with maximum inertia and the above load type is 46 seconds. Safe stall time at 100% voltage is 102 seconds cold, 68 seconds hot. Rotor inertia is 1.13 Lb-Ft Sq (0.05 Kg-meter Sq).

| | | | |
|---------------------------|-------|---------------------------|-------|
| Open Circuit A-C: | 0.422 | Short Circuit D-C: | 0.013 |
| Short Circuit A-C: | 0.02 | X/R Ratio: | 4.867 |
| Stator Slots: | 36 | Rotor Slots: | 28 |

Speed Torque Current Curve (First Connection, First Speed)

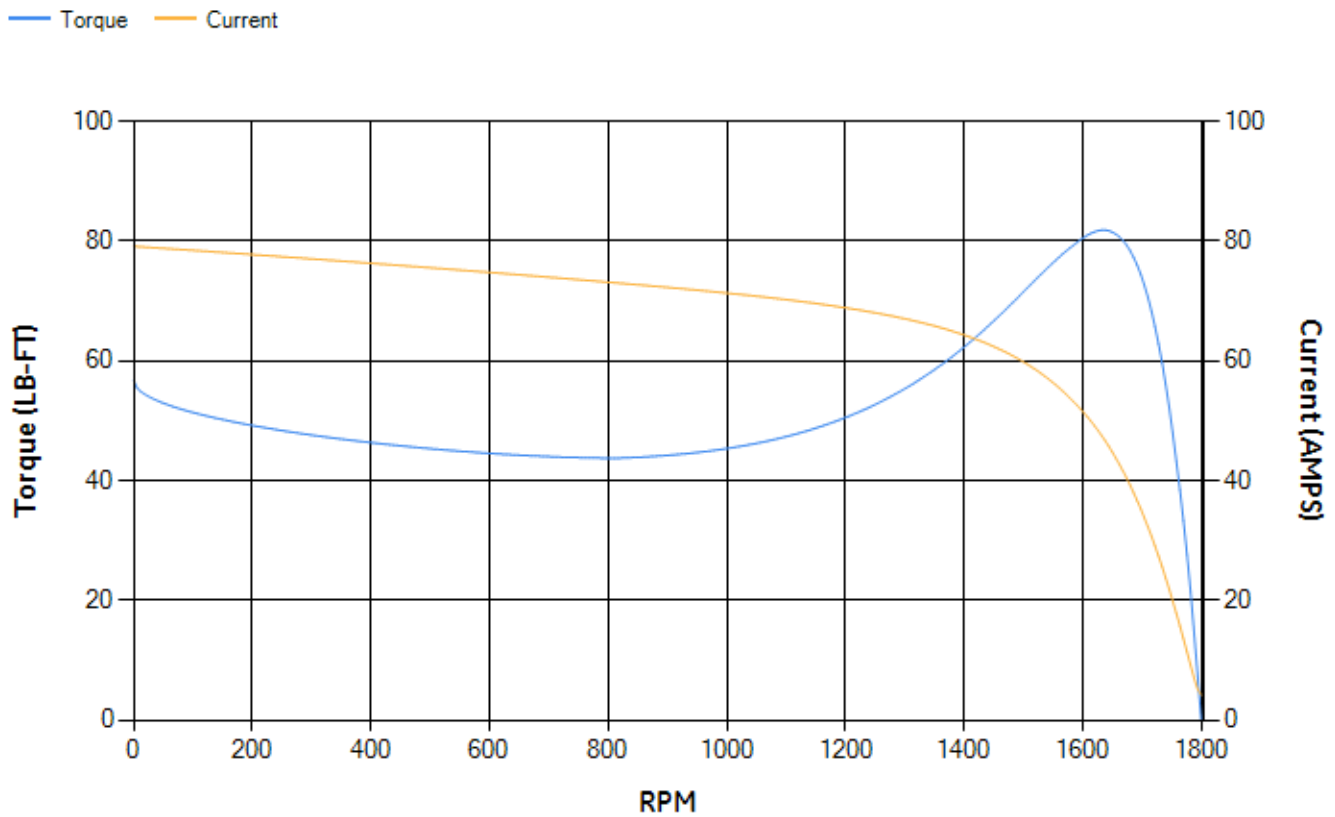

Marks:

NOTE 1: CONDUIT BOX MAY BE ASSEMBLED WITH ENTRANCE UP, DOWN OR TO EITHER SIDE.
 NOTE 2: F1 ASSEMBLY AS SHOWN. F2 ASSEMBLY CONDUIT BOX ON OPPOSITE SIDE FROM SHOWN LOCATION.

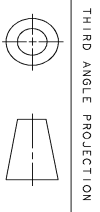
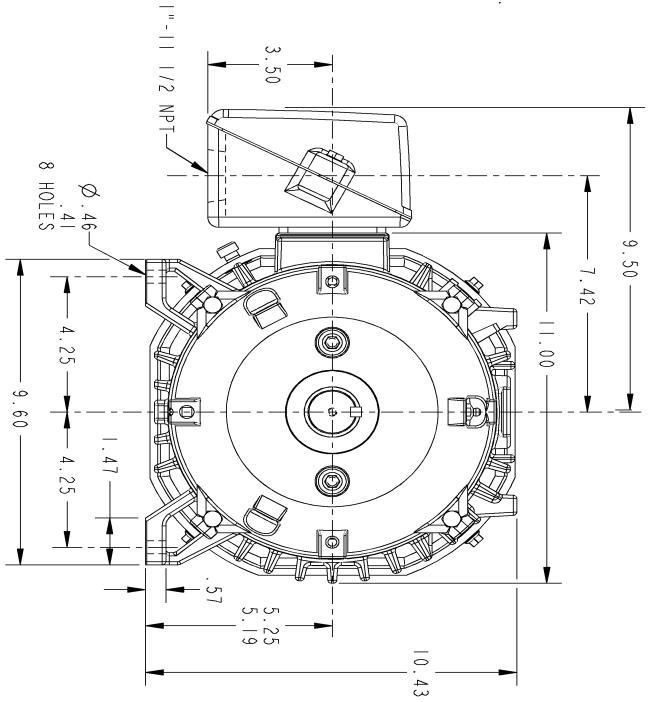
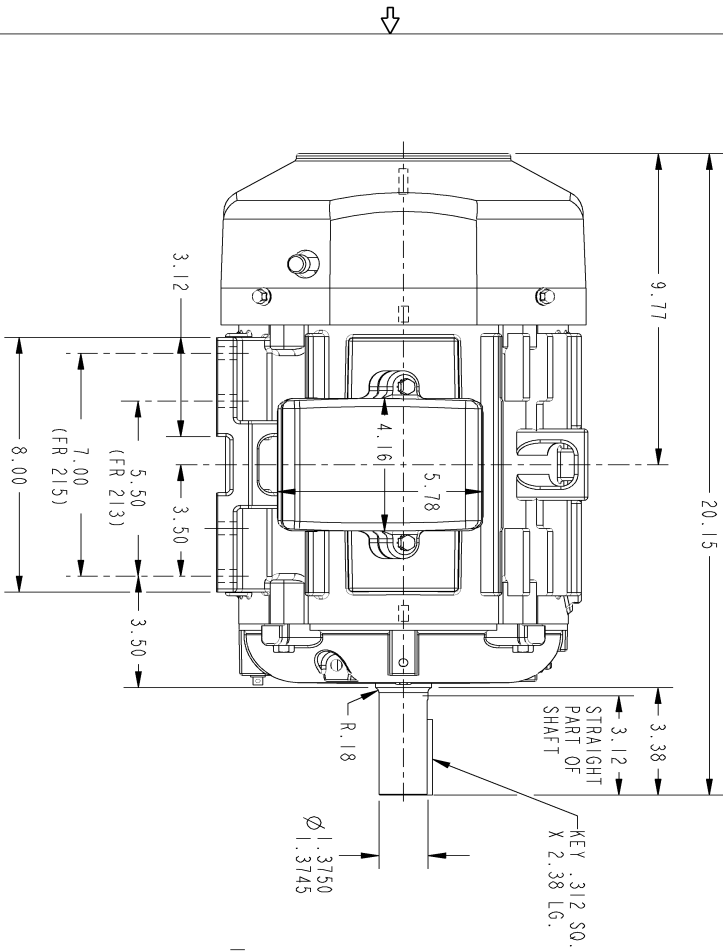

SIZE B DRAWING NO. 4002B5821PAP5201

SH 1 REV 1

| REVISIONS | | | |
|-----------|---------------|------------|----------|
| REV. | DESCRIPTION | DATE | APPROVED |
| 1 | ISAC #15-0018 | 08/01/2015 | ADI |

| SIGNATURES | DATE | GE Industrial Systems GENERAL ELECTRIC COMPANY Fort Wayne, Indiana | |
|----------------------|-----------|---|--------------|
| DRWN: GARY WARRNER | JUN 22/02 | INDUCTION MOTOR OUTLINE STANDARD CONSTRUCTION FME: FR23/25T TFC | |
| CHCKD: GARY WARRNER | FEB 09/02 | | |
| ENGR: GARY WARRNER | SEP 03/02 | | |
| ISSUED: GARY WARRNER | SEP 03/02 | | |
| APPLIED PRACTICES | | SIZE DRAWING | REV. |
| | | B | 1 |
| SCALE: 0.300 | | REF. NO: 4002B5821PAP201 | SHEET 1 OF 1 |

DISTRIBUTION: PMP-1BK15

Marks:

Connection Diagram
GEM2034E-FIG9



| End shield Assembly | | |
|---------------------|---------------|----------------|
| Part Description | DE Side Part# | ODE Side Part# |
| End Shield | 4004D5282PB1 | 4004D5282SJ1 |
| Bearing | 235A2603AA01 | 235A2603AA01 |
| Slinger/Inproseal | 149C4399G01 | 149C4399G01 |

| Fan & Fan Cover Assembly | |
|--------------------------|--------------|
| Part Description | Part# |
| Fan | 159C6700G01 |
| Fan Cover | 4003C5787PA1 |

| Conduit & Accessories Box Assembly | |
|------------------------------------|-----------------|
| Part Description | Part# |
| Conduit Box | 4002B5721PA-G01 |

| Mechanical Accessories | |
|------------------------|-------|
| Part Description | Part# |
| Brake | |
| Tachometer | |