

TYPE	OUTPUT		POLE	TIME RATING	VOLTAGE V	Hz	SYN.SPEED R.P.M
	HP.	kW.					
AEHHXU	150	112	4	CONT.	460	60	1800

TOTALLY ENCLOSED FAN-COOLED TYPE, SQUIRREL-CAGE ROTOR

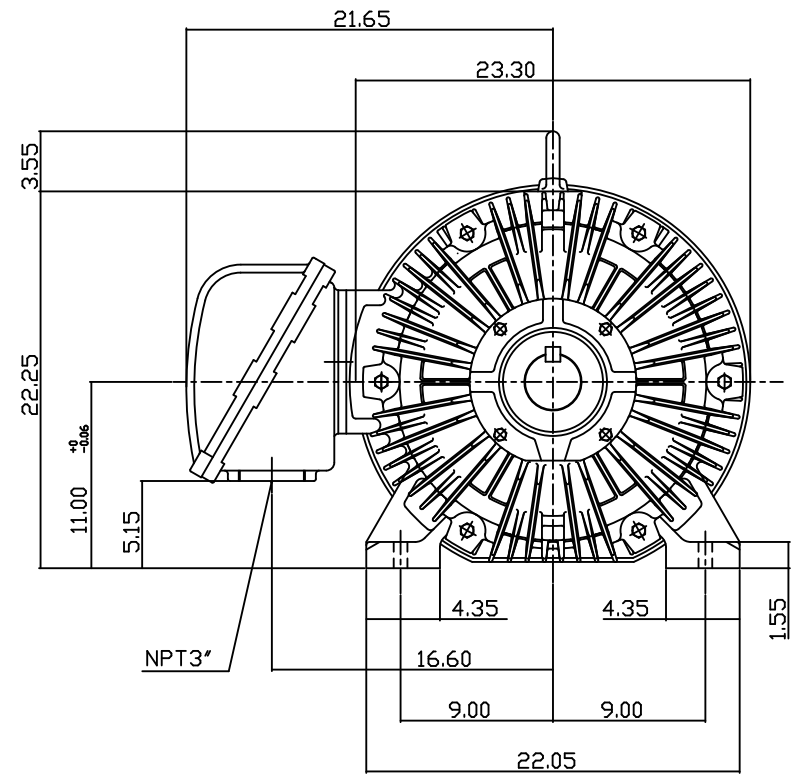
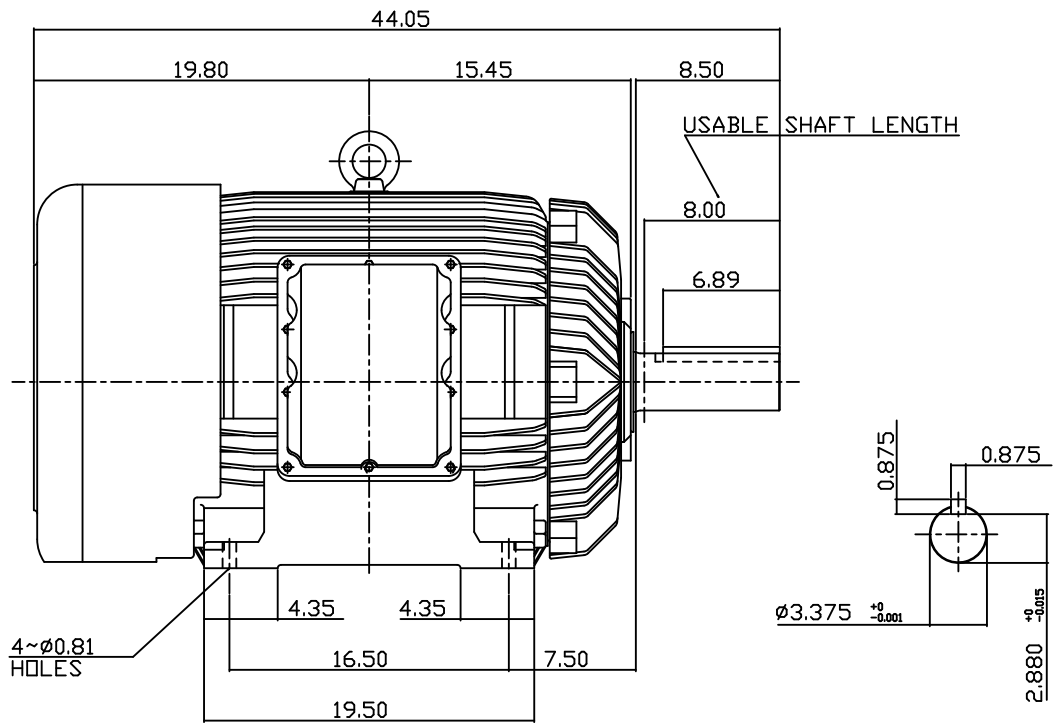

- NOTE:
1. DIMENSIONS IN INCH.
 2. FRAME NO. 445T
 3. F CLASS INSULATION, S.F.1.15
 4. UL EXPLOSION PROOF
 5. SUITABLE FOR DIVISION I, CLASS I, GROUP D, CLASS II, GROUP E,F,G.
 6. BEARING SIZE: DRIVE END: NU318
NON-DRIVE END: 6318
 7. MOTOR APPROX. WEIGHT: 1780 LBS

TX-56

DWN.	W.L.LIN	APR-07-2003
CHKD.	W.L.LIN	APR-07-2003
APPD.	C.WANG	APR-07-2003

DATE
MAY 2, 2011
CATALOG NO.
XP1504R

OUTLINE DIMENSIONS
3-PHASE INDUCTION MOTOR

TEC Westinghouse

DWG NO. REV: 01
3A040T3291-1