

Product Information Packet

November 8, 2016

Data shown is for the current revision model #. Ensure your nameplate model # matches.

Model Number:	5KS213XAA304D2
Catalog Number:	M9490
Instruction Manual:	GEI-56128
Connection Diagram:	GEM2034E-FIG1
Outline Drawing:	4002B5821PAP5311

Accessory Connection Diagrams

Bearing Thermocouple:	None	Heater:	None
RTD:	None	Thermistor:	None
Thermostat:	None	Winding Thermocouple:	None
Bearing RTD:	None		

Table of Contents

Specification	01
Performance Characteristics	02
Outline Drawing	03
Connection Drawing(s)	04
Spare parts	05



Marks:

MODEL NUMBER:	5KS213XAA304D2	Estimated Weight:	200 Lbs
Outline Drawing:	4002B5821PAP5311	Time Rating:	CONT
Connection Diagram:	GEM2034E-FIG1	Enclosure:	TEFC
Instruction Book:	GEI-56128	Encl Construction:	841
Design Code:	21BD3003B	Ambient Max(°C):	40
Type:	KS	Alt Ambient Max(°C):	--
Frame:	213T	Insulation Class:	H
Phases:	3	NEMA Design:	B
Poles:	6	Nominal Efficiency:	89.5 %
Output Power:	3HP 2.2KW	Guaranteed Efficiency:	88.5
RPM:	1175	3/4 Load Efficiency:	89.5
Voltage:	575	KVA Code:	K
Hertz:	60	Max KVAR:	1.6
Amps - FL:	3.4	Power Factor:	73.0
Service Factor:	1.15	Bearing - DE:	6208ZC3
Alt Service Factor:	--	Bearing - ODE:	6208ZC3

Enclosure is Totally Enclosed Fan-Cooled

Stamped Nameplate Notes:

IEEE-STD-841-2009
 DE BRG 40BC02JP30 ODE BRG 40BC02JP30
 STAMP NP249A5564P051 AS BELOW:
 MODEL:5KS213XAA304D2 S/N: XXX
 CSA CERTIFIED CSA09.2216219 FOR EX NA IIC 200C GC
 CL 1 ZONE2 AEX NA IIC 200C;CL 1 DIV2 GRP ABCD 200C
 IN -25C <= AMB <= 40C, 1.0 SF ON SINE-WAVE PWR
 SURF TEMP 200C AT 1.15SF ON SINE-WAVE PWR
 OR 200 C VT OR 200 C CT OR 200 C CHP PWM CONTROL
 ALTERNATE RATING FOR PWM CONTROL 1.0SF 40C AMB
 VT 0-60 HZ, CT 3-60 HZ, CHP 60-90 HZ.

Additional Information:

6P - T EXTN
 STANDARD FLOOR MOUNT
 C/BOX 55 CU IN-1.00 NPT
 F1 CONDUIT BOX MOUNTING
 PAINTED FRAME ID & SHAFT,
 FAN COVER INSIDE & ODE E/S OUTSIDE
 ROUTINE AND 5 POINT VIBRATION TESTS INCL IN C/BOX
 INPRO SEAL BOTH ENDS
 GROUND SCREW ON FRAME
 SHAFT RUNOUT LIMIT .001" TIR
 COPPER WASHER UNDER HEADS OF BEARING CAP BOLTS
 APPLY TITE-SEAL (A50CD427A) ON BEARING CAP SCREWS, RABBETS,
 AND PLUG THREADS
 OIL RESISTANT SLEEVING ON LEADS

Performance Characteristics

1st Winding 1st Connection

Design: 21BD3003B

Marks:

LOAD %	125.0	115.0	100.0	75.0	50.0	25.0	0.0
% EFF	88.41	88.84	89.53	89.54	88.33	82.44	0.00
% PF	77.06	75.82	73.23	66.24	54.02	33.97	5.7
AMPS	4.12	3.84	3.43	2.84	2.35	2.01	1.84

TORQ(FL)#FT	13.38	TORQ(LR)%FL	206.36	TORQ(BD)%FL	330.14
AMPS(LR)	23.75	PF AT START	0.47		

This motor is capable of two cold or one hot start with a maximum connected load inertia of 392 Lb-Ft Sq (16.5 Kg-meter Sq)at 100% voltage, where the load torque varies with the square of the speed. Acceleration time with maximum inertia and the above load type is 55 seconds. Safe stall time at 100% voltage is 123 seconds cold, 98 seconds hot. Rotor inertia is 0.65 Lb-Ft Sq (0.03 Kg-meter Sq).

Open Circuit A-C:	0.237	Short Circuit D-C:	0.009
Short Circuit A-C:	0.015	X/R Ratio:	3.328
Stator Slots:	36	Rotor Slots:	44

Speed Torque Current Curve (First Connection, First Speed)

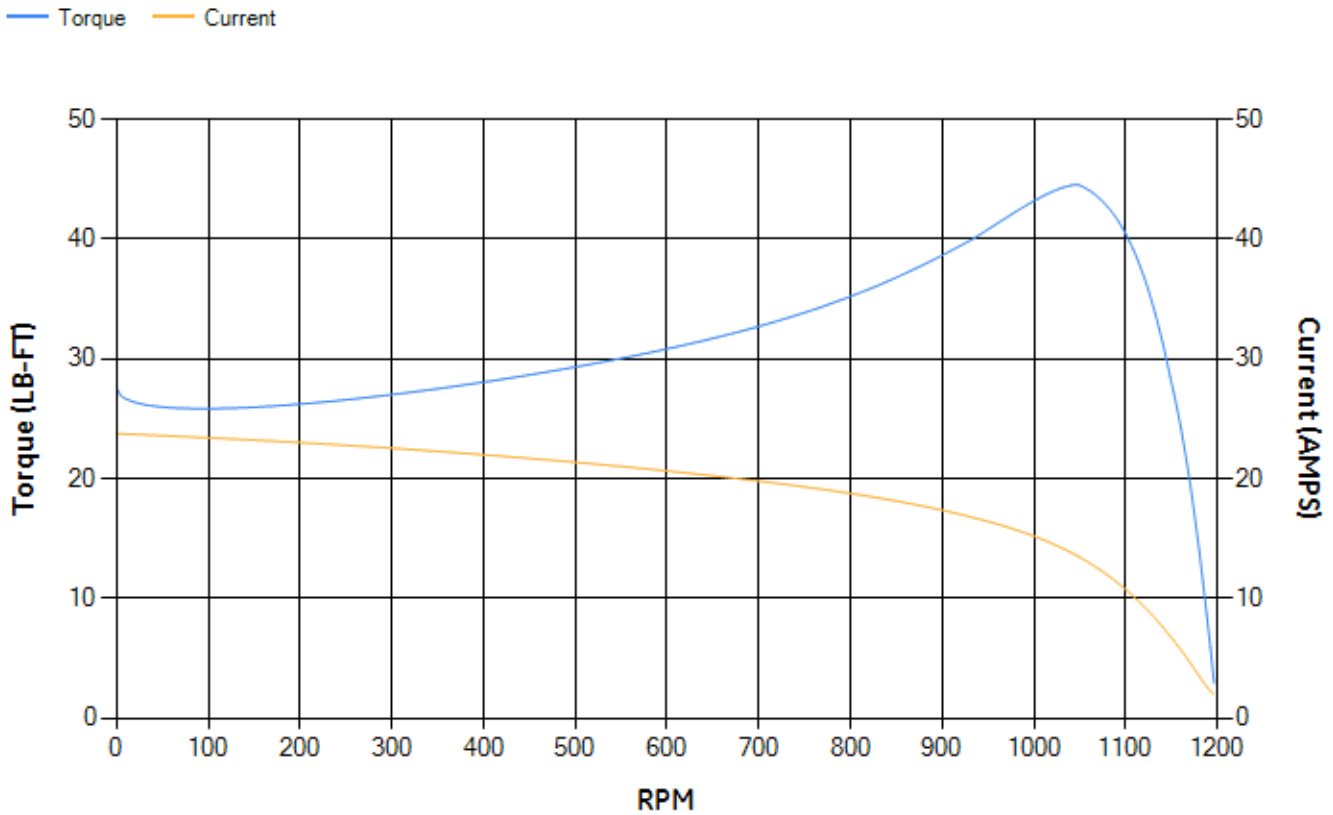

Marks:

NOTE 1: CONDUIT BOX MAY BE ASSEMBLED WITH ENTRANCE UP OR DOWN OR TO EITHER SIDE.
 NOTE 2: F1 ASSEMBLY AS SHOWN. F2 ASSEMBLY CONDUIT BOX ON OPPOSITE SIDE FROM SHOWN LOCATION.
 NOTE 3: SHAFT RUNOUT WILL NOT EXCEED .001 T.I.R.
 NOTE 4: ALL DIMENSIONS ARE IN INCHES, BRACKETED DIMENSIONS ARE IN METRIC (MILLIMETERS).

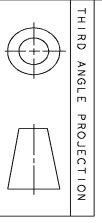
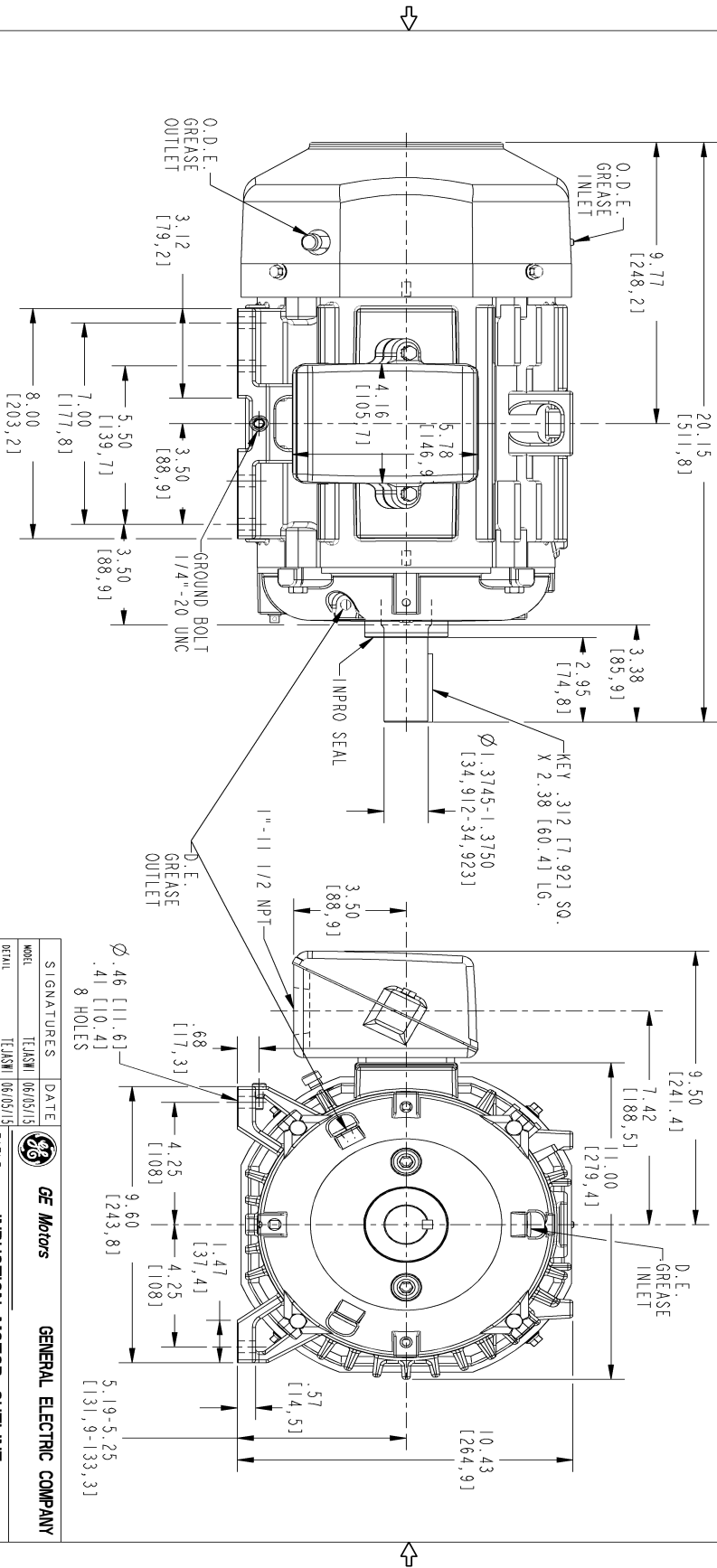

SIZE DRAWING NO. B

4002B5821PAP5311 0

REV.	DESCRIPTION	DATE	APPROVED

SIGNATURES	DATE
TEJASNI	06/05/15
TEJASNI	06/05/15
VENKAT	06/05/15
VENKAT	06/05/15
ISSUED	06/05/15

GE Motors GENERAL ELECTRIC COMPANY

TITLE: **INDUCTION MOTOR OUTLINE**
 STANDARD CONSTRUCTION FOR IEEE-841 SPEC
 FNM: FR2/215 T TFC

SCALE: 0.300 REF. No.: 4002B5821PAP5301

4002B5821PAP5311 0

SHEET 1 of 1

Marks:

Connection Diagram
GEM2034E-FIG1



End shield Assembly		
Part Description	DE Side Part#	ODE Side Part#
End Shield	4004D5282PB1	4004D5282SJ1
Bearing	235A2603AA01	235A2603AA01
Slinger/Inproseal	4002B5914AF3	4002B5914AG3

Fan & Fan Cover Assembly	
Part Description	Part#
Fan	159C6700G01
Fan Cover	4003C5787PA1

Conduit & Accessories Box Assembly	
Part Description	Part#
Conduit Box	4002B5721PA-G01

Mechanical Accessories	
Part Description	Part#
Brake	
Tachometer	