

# Product Information Packet

January 13, 2017

Data shown is for the current revision model #. Ensure your nameplate model # matches.

<b>Model Number:</b>	<b>5KS254DAE6034B</b>
<b>Catalog Number:</b>	<b>V4404</b>
<b>Instruction Manual:</b>	GEK-95353
<b>Connection Diagram:</b>	GEM2034E-FIG9
<b>Outline Drawing:</b>	4002B5825NMP5210

Accessory Connection Diagrams			
<b>Bearing Thermocouple:</b>	None	<b>Heater:</b>	3027JE-1C
<b>RTD:</b>	None	<b>Thermistor:</b>	None
<b>Thermostat:</b>	None	<b>Winding Thermocouple:</b>	None
<b>Bearing RTD:</b>	None		

## Table of Contents

Specification	01
Performance Characteristics	02
Outline Drawing	03
Connection Drawing(s)	04
Spare parts	05



**Marks:**

<b>MODEL NUMBER:</b>	<b>5KS254DAE6034B</b>	<b>Estimated Weight:</b>	280 Lbs
<b>Outline Drawing:</b>	4002B5825NMP5210	<b>Time Rating:</b>	CONT
<b>Connection Diagram:</b>	GEM2034E-FIG9	<b>Enclosure:</b>	WPI
<b>Instruction Book:</b>	GEK-95353	<b>Encl Construction:</b>	OPEN
<b>Design Code:</b>	25BD1120A	<b>Ambient Max(°C):</b>	40
<b>Type:</b>	KS	<b>Alt Ambient Max(°C):</b>	--
<b>Frame:</b>	L254TP10	<b>Insulation Class:</b>	H
<b>Phases:</b>	3	<b>NEMA Design:</b>	B
<b>Poles:</b>	4	<b>Nominal Efficiency:</b>	93 %
<b>Output Power:</b>	15HP 11.1KW	<b>Guaranteed Efficiency:</b>	91.7
<b>RPM:</b>	1775	<b>3/4 Load Efficiency:</b>	93.5
<b>Voltage:</b>	230/460	<b>KVA Code:</b>	G
<b>Hertz:</b>	60	<b>Max KVAR:</b>	4.9
<b>Amps - FL:</b>	36.0/18.0	<b>Power Factor:</b>	84.0
<b>Service Factor:</b>	1.15	<b>Bearing - DE:</b>	7309
<b>Alt Service Factor:</b>	--	<b>Bearing - ODE:</b>	6209-2ZC3

**Enclosure is Weather Protected One**

**Stamped Nameplate Notes:**

PREMIUM EFFICIENT MOTOR  
 NEMA ENCL WPI AND CSA ENCL DP  
 ROT CCW FACING ODE LEAD/PH SEQUENCE 1-2-3/1-2-3  
 HTR LDS HE1-HE2 115V 60W  
 INVERTER DUTY PER NEMA MG1 PART 31  
 ALTERNATE RATING FOR PWM CONTROL:  
 1.0 SF VAR TORQUE RANGE 20-60 HZ  
 SUITABLE FOR 10HP, 190/380V,  
 50 HZ WITH 29.8/14.9AMPS AND 1480 RPM AT 1.0 SF

**Additional Information:**

4P - TP EXTN  
 C/BOX 137 CU IN-1.25 NPT  
 AUX LEADS EXIT WITH MOTOR LEADS  
 RCF 5000 CPM, STATIC DEFLECTION .0014 INCHES &  
 CENTER OF GRAVITY 10.75 INCHES  
 HOLLOW SHAFT HIGH THRUST  
 OIL RESISTANT SLEEVING ON LEADS  
 BEARING LIFE 8760 HOURS AT 2575 LB THRUST  
 BALL TYPE COUPLING  
 COUPLING WILL BE ORDERED SEPARATELY  
 DP STOCK 10/21/2016  
 ENGINEERED BY: BALASUBRAMANIANH/BILURP

**Performance Characteristics**

1st Winding 1st Connection

**Design: 25BD1120A**

**Marks:**

LOAD %	125.0	115.0	100.0	75.0	50.0	25.0	0.0
% EFF	92.05	92.45	93.16	93.47	93.19	90.22	0.00
% PF	85.59	85.19	84.06	80.05	70.66	48.57	4.77
AMPS	22.27	20.5	17.93	14.07	10.66	8.01	6.76

<b>TORQ(FL)#FT</b>	44.35	<b>TORQ(LR)%FL</b>	191.63	<b>TORQ(BD)%FL</b>	250.41
<b>AMPS(LR)</b>	99.56	<b>PF AT START</b>	0.45		

This motor is capable of two cold or one hot start with a maximum connected load inertia of 529 Lb-Ft Sq (22.27 Kg-meter Sq)at 100% voltage, where the load torque varies with the square of the speed. Acceleration time with maximum inertia and the above load type is 49 seconds. Safe stall time at 100% voltage is 108 seconds cold, 87 seconds hot. Rotor inertia is 2.31 Lb-Ft Sq (0.1 Kg-meter Sq).

<b>Open Circuit A-C:</b>	0.51	<b>Short Circuit D-C:</b>	0.014
<b>Short Circuit A-C:</b>	0.027	<b>X/R Ratio:</b>	5.15
<b>Stator Slots:</b>	48	<b>Rotor Slots:</b>	40

**Speed Torque Current Curve (First Connection, First Speed)**

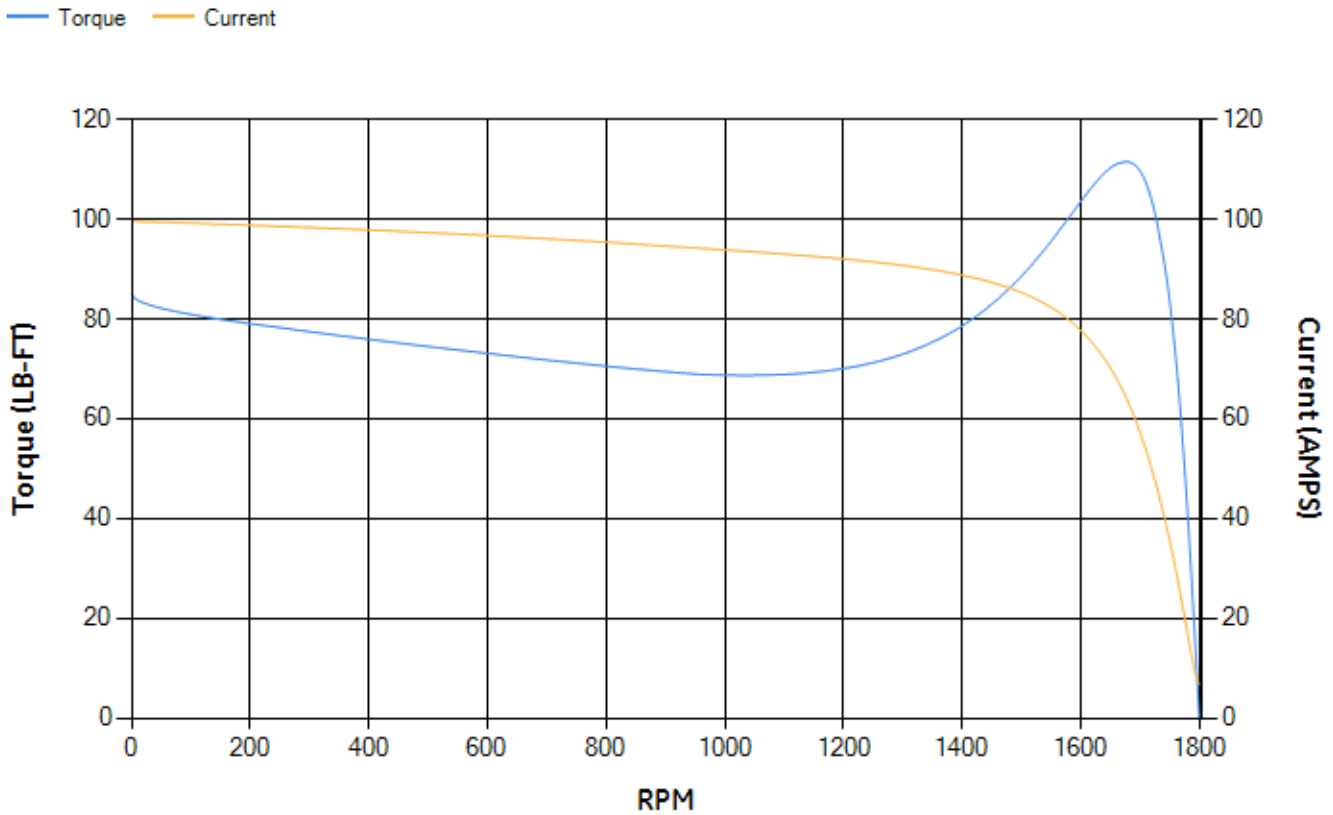

NAME:320002276 OBJECT:4002B5825NMP5210 DATE:17-Feb-09 17:50:51

Marks:

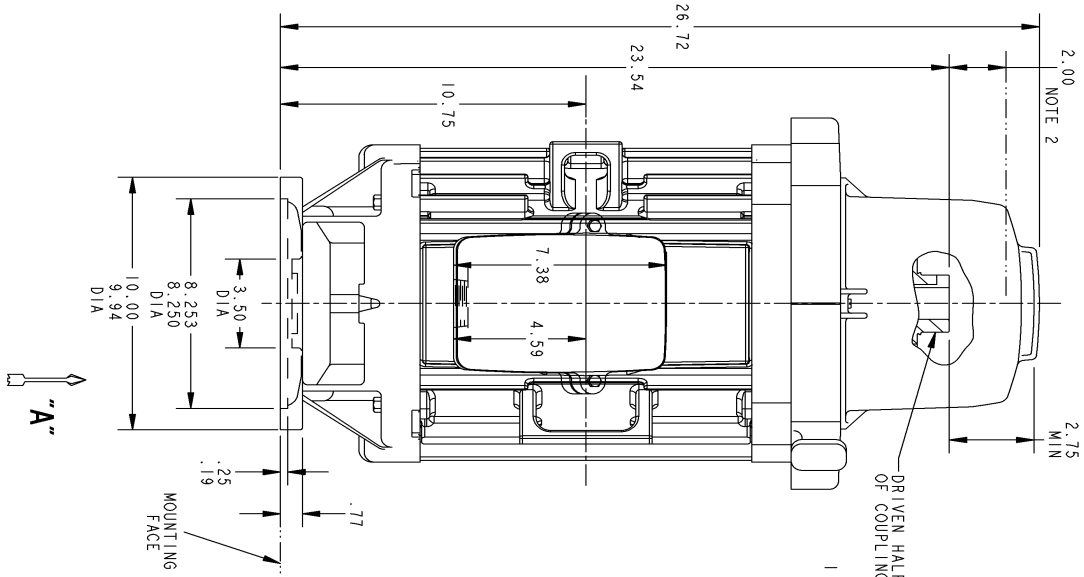

VIEW AT ARROW "A"  
 NOTE 1: CONDUIT BOX MAY BE ASSEMBLED WITH ENTRANCE UP, DOWN, OR TO EITHER SIDE.  
 NOTE 2: THE TOTAL HEIGHT OF PUMP SHAFT & LOCKING NUT ABOVE TOP OF COUPLING, MUST NOT EXCEED THIS DIMENSION.

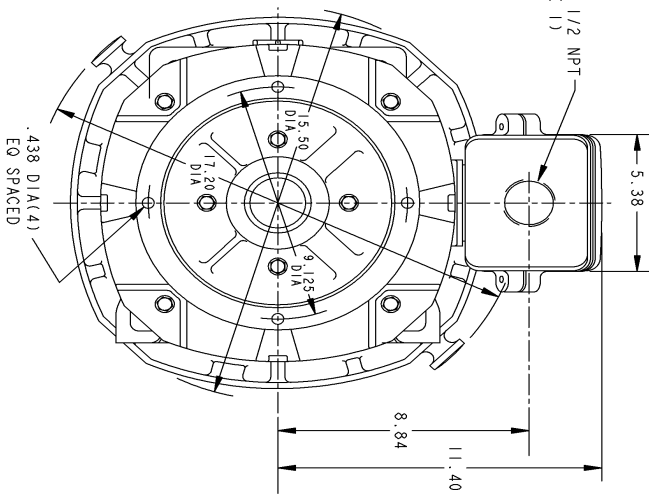

DRIVEN HALF OF COUPLING

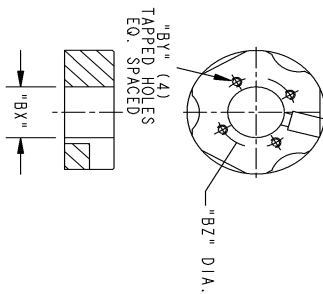

COUPLING KIT	GR. No.	"BY"	"BZ"	BONE DIA.	"BX"	"W"	"D"	KEYWAY
4002B5825NMP5210	1	1/4-20	1.750	1.352	1.452	1.188	1.188	250 .125
	2			1.188	1.188	1.002	1.001	
	3			1.002	1.002	1.001	1.001	
4002B5825NMP5210 NON-REVERSE	4	#10-32	1.375	.817	.817	.752	.188	.094
	5			.752	.752	.752	.188	.094
	6			.752	.752	.752	.188	.094
	7	1/4-20	1.750	1.252	1.252	1.251	.375	.188
4002B5825NMP5210 4002B5825NMP5210AB BOLTED OR SELF-RELEASE	1	1/4-20	1.750	1.252	1.252	1.251	.375	.188
	2			1.188	1.188	1.002	1.002	.250 .125
	3			1.002	1.002	1.001	1.001	
4002B5825NMP5210AB BOLTED OR SELF-RELEASE	4	#10-32	1.375	.816	.816	.751	.188	.094
	5			.816	.816	.751	.188	.094
4002B5825NMP5210AB BOLTED OR SELF-RELEASE	6			.751	.751	.751	.188	.094
	7	1/4-20	1.750	1.252	1.252	1.251	.375	.188

PRINTS TO

NAME	DATE

CAD NO.	4002B5825NMP5210	PETERBOROUGH	4002B5825NMP5210
REF.	4002B5825NMP210	MOTOR PLANT	CONT. ON SH. "
PLOT CLASS			SH. NO. /
PLOT SCALE	.25	TITLE	
		INDUCTION MOTOR OUTLINE	
		WP-1 STANDARD "P" BASE VERTICAL C.I.R.	
		FIRST MADE FOR FR250	
		HOLLOW SHAFT - HIGH THRUST (BD=10)	

REV	DESCRIPTION	DATE	INT'L	DRAWN	CHECKED	DATE
1	ISAAC NO: #09-0117 ATUL	02/16/09	RAGH	VILAV	ADINARAYANA	08/16/09
CAD DRAWING - NO MANUAL REVISIONS PERMITTED						
				4002B5825NMP5210		
				CONT. ON SH. "		
				SH. NO. /		

Marks:

**Connection Diagram**  
**GEM2034E-FIG9**

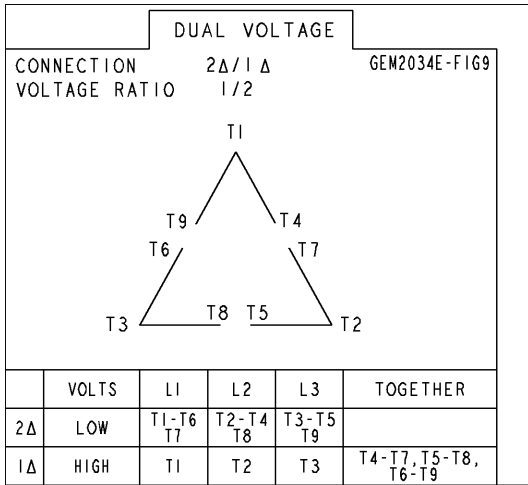

**Heater Connection**  
**3027JE-1C**



End shield Assembly		
Part Description	DE Side Part#	ODE Side Part#
End Shield	128D6124PA1	128D6128PA1
Bearing	235A2507AC01	235A2507EE01
Slinger/Inproseal	235A2300FL3	

Fan & Fan Cover Assembly	
Part Description	Part#
Fan	
Fan Cover	

Conduit & Accessories Box Assembly	
Part Description	Part#
Conduit Box	4002B5728PA-G04

Mechanical Accessories	
Part Description	Part#
Brake	
Tachometer	

