

TYPE	OUTPUT		POLE	RATING	VOLTAGE	Hz	SYNSPEED R.P.M
	HP.	KW.					
AEHH	100	74.6	6	CDNT.	460	60	1200

TOTALLY ENCLOSED FAN-COOLED TYPE, SQUIRREL-CAGE ROTOR

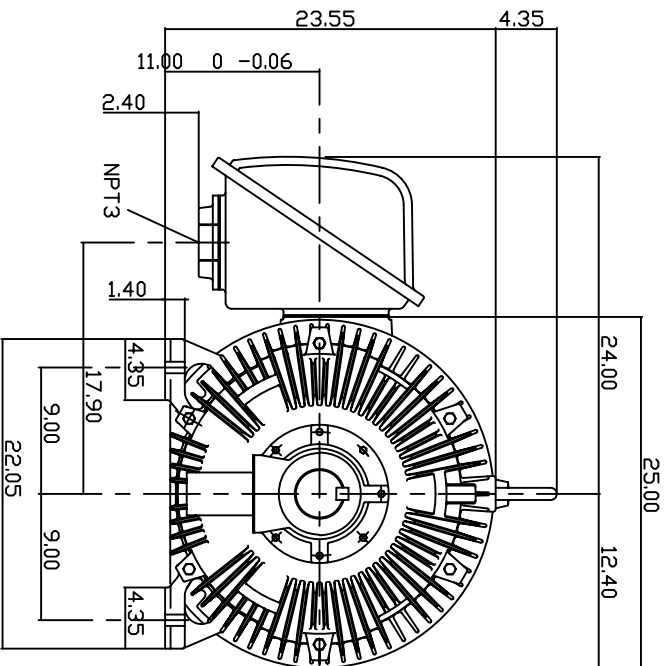
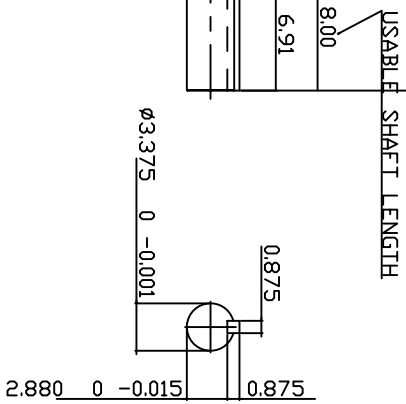
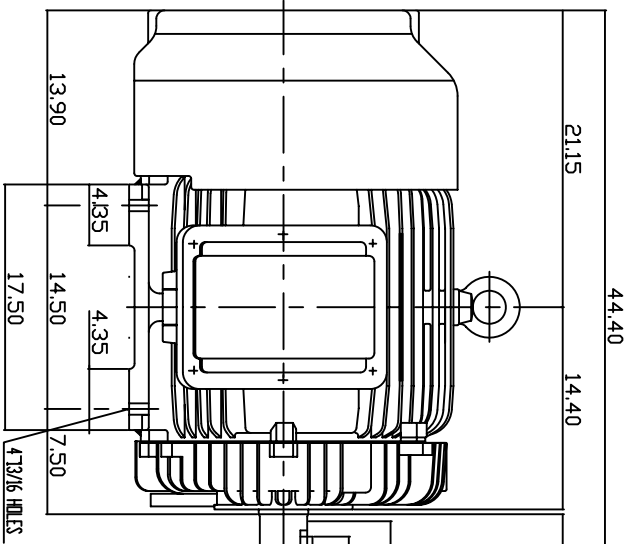

NOTE:

1. DIMENSIONS IN INCH
2. FRAME NO. 444T
3. F CLASS INSULATION, S.F.1.15
4. FOR DIRECT FLEXIBLE COUPLING
5. ENCLOSURE: IP55
6. BEARING SIZE: DRIVE END: 6318C3
NON-DRIVE END: 6316C3
7. APPROX. WEIGHT: 1650 LBS
8. NON-SPARKING FAN.
9. NOISE: BELOW 83 DBA AT 1 METER, NO LOAD.

TW-56C

DWN.	T.H.Pan	FEB 18 2005
CHKD.	H.HUANG	FEB 18 2005
APPD.	C.WANG	FEB 18 2005

DATE	06-20-05	OUTLINE DIMENSIONS
CATALOG #	HH1006	3-PHASE INDUCTION MOTOR

Westinghouse
Dwg No. 3A040Y696
REV: 00