

Product Information Packet

November 9, 2016

Data shown is for the current revision model #. Ensure your nameplate model # matches.

Model Number:	5KS143XAA204D2
Catalog Number:	M353
Instruction Manual:	GEI-56128
Connection Diagram:	GEM2034E-FIG1
Outline Drawing:	4002B5814PAP5311

Accessory Connection Diagrams			
Bearing Thermocouple:	None	Heater:	None
RTD:	None	Thermistor:	None
Thermostat:	None	Winding Thermocouple:	None
Bearing RTD:	None		

Table of Contents

Specification	01
Performance Characteristics	02
Outline Drawing	03
Connection Drawing(s)	04
Spare parts	05



Marks:

MODEL NUMBER:	5KS143XAA204D2	Estimated Weight:	43 Lbs
Outline Drawing:	4002B5814PAP5311	Time Rating:	CONT
Connection Diagram:	GEM2034E-FIG1	Enclosure:	TEFC
Instruction Book:	GEI-56128	Encl Construction:	841
Design Code:	14BD1092B	Ambient Max(°C):	40
Type:	KS	Alt Ambient Max(°C):	--
Frame:	143T	Insulation Class:	H
Phases:	3	NEMA Design:	B
Poles:	4	Nominal Efficiency:	85.5 %
Output Power:	1HP 0.7KW	Guaranteed Efficiency:	84.0
RPM:	1755	3/4 Load Efficiency:	84.9
Voltage:	575	KVA Code:	N
Hertz:	60	Max KVAR:	0.7
Amps - FL:	1.2	Power Factor:	71.0
Service Factor:	1.15	Bearing - DE:	6205ZC3
Alt Service Factor:	--	Bearing - ODE:	6205ZC3

Enclosure is Totally Enclosed Fan-Cooled

Stamped Nameplate Notes:

IEEE-STD-841-2009
 DE BRG 25BC02JP30 ODE BRG 25BC02JP30
 STAMP NP249A5564P051 AS BELOW:
 MODEL:5KS143XAA204D2 S/N: XXX
 CSA CERTIFIED CSA09.2216219 FOR EX NA IIC 200 C GC
 CL1 ZONE2 AEXNAIIC 200C FOR CL1DIV2 GRP ABCD 200C
 IN -25C <= AMB <= 40C, 1.0 SF ON SINE-WAVE PWR
 SURF TEMP 200C AT 1.15 SF ON SINE-WAVE PWR
 OR 200 C VT OR 200 C CT OR 200 C CHP PWM CONTROL
 ALTERNATE RATING FOR PWM CONTROL 1.0 SF 40 C AMB
 VT 0-60 HZ, CT 3-60 HZ, CHP 60-90 HZ.

Additional Information:

4P - T EXTN
 STANDARD FLOOR MOUNT
 C/BOX 30 CU IN-0.75 NPT
 F1 CONDUIT BOX MOUNTING
 PAINTED FRAME ID & SHAFT,
 FAN COVER INSIDE & ODE E/S OUTSIDE
 ROUTINE AND 5 POINT VIBRATION TESTS INCL IN C/BOX
 INPRO SEAL BOTH ENDS
 GROUND SCREW ON FRAME
 SHAFT RUNOUT LIMIT .001" TIR
 COPPER WASHER UNDER HEADS OF BEARING CAP BOLTS
 APPLY TITE-SEAL (A50CD427A) ON BEARING CAP SCREWS, RABBETS,
 AND PLUG THREADS
 OIL RESISTANT SLEEVING ON LEADS

Performance Characteristics

1st Winding 1st Connection

Design: 14BD1092B

Marks:

LOAD %	125.0	115.0	100.0	75.0	50.0	25.0	0.0
% EFF	85.44	85.62	85.88	84.94	82.07	72.54	0.00
% PF	76.96	74.81	72.58	61.86	48.69	30.53	8.29
AMPS	1.42	1.34	1.2	1.07	0.94	0.85	0.75

TORQ(FL)#FT	3	TORQ(LR)%FL	468.49	TORQ(BD)%FL	537.99
AMPS(LR)	10.1	PF AT START	0.68		

This motor is capable of two cold or one hot start with a maximum connected load inertia of 83 Lb-Ft Sq (3.49 Kg-meter Sq) at 100% voltage, where the load torque varies with the square of the speed. Acceleration time with maximum inertia and the above load type is 37 seconds. Safe stall time at 100% voltage is 82 seconds cold, 65 seconds hot. Rotor inertia is 0.08 Lb-Ft Sq (0 Kg-meter Sq).

Open Circuit A-C:	0.13	Short Circuit D-C:	0.005
Short Circuit A-C:	0.006	X/R Ratio:	1.75
Stator Slots:	36	Rotor Slots:	48

Speed Torque Current Curve (First Connection, First Speed)

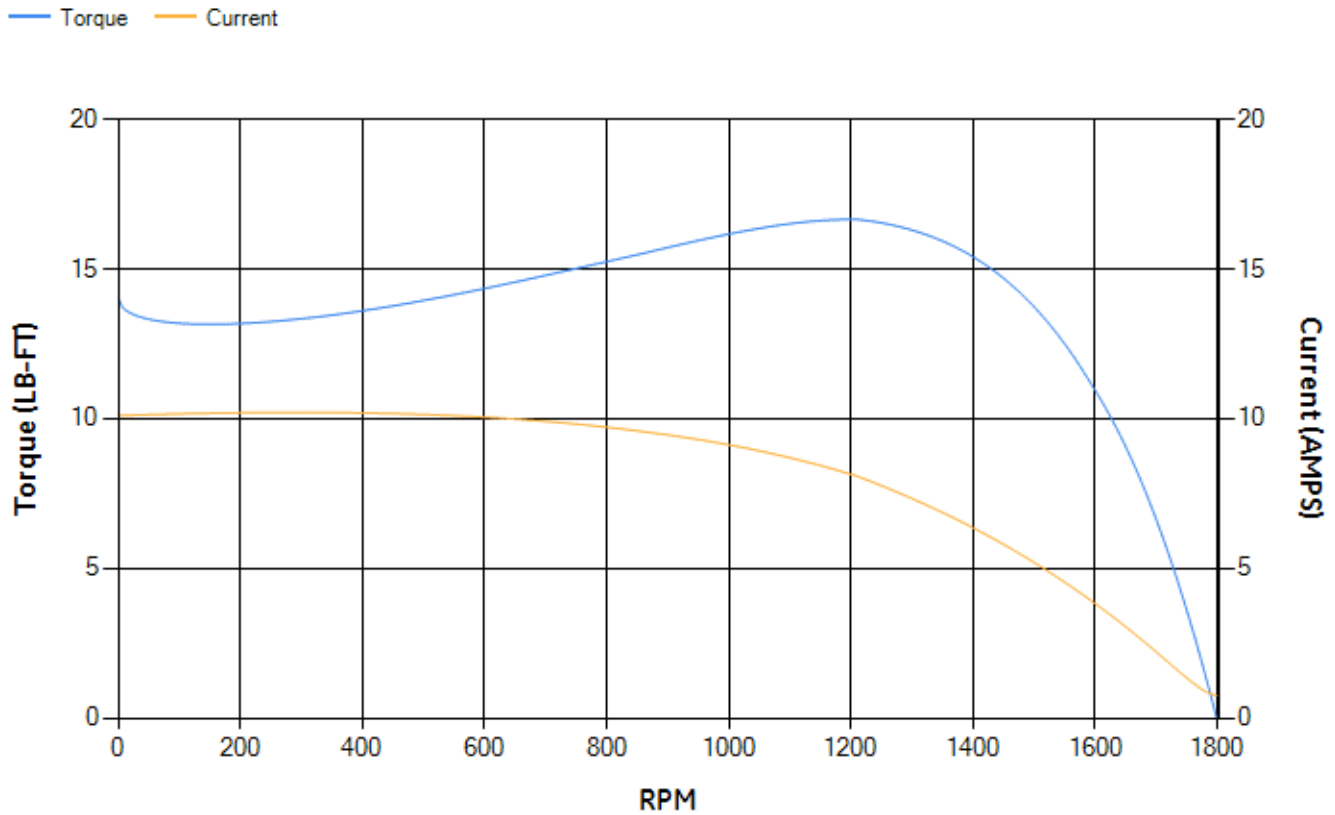

Marks:

NOTE 1: CONDUIT BOX MAY BE ASSEMBLED WITH ENTRANCE UP, DOWN OR TO EITHER SIDE.
 NOTE 2: FL ASSEMBLY AS SHOWN.
 NOTE 3: SHAFT RUNOUT WILL NOT EXCEED .001 I. I. R.
 NOTE 4: ALL DIMENSIONS ARE IN INCHES, BRACKETED DIMENSIONS ARE IN METRIC (MILLIMETERS).

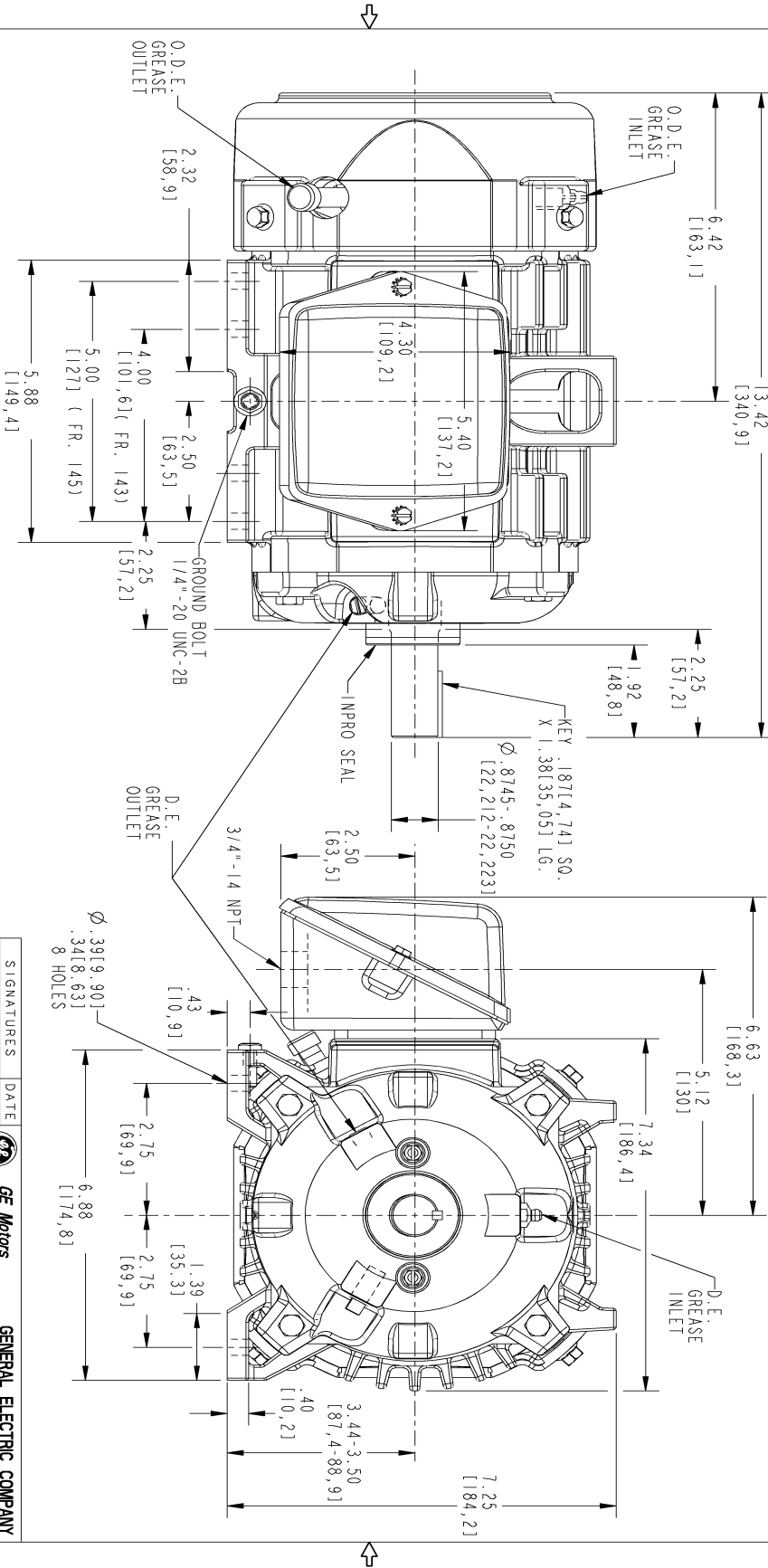

SIZE	DRAWING NO.	REV	SHEET
B	4002B5814PAP5311	1	1

REVISIONS			
REV.	DESCRIPTION	DATE	APPROVED
1	ISAC # 15-0944 HARIKIRAN	09/24/15	SAGAR

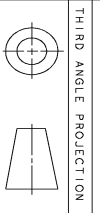

THIRD ANGLE PROJECTION

SIGNATURES		DATE	 GENERAL ELECTRIC COMPANY
MODEL	TEJASNI	06/03/15	
DETAIL	TEJASNI	06/03/15	INDUCTION MOTOR OUTLINE STANDARD CONSTRUCTION FOR IEEE-841 SPEC FME: FR140T TFC 4002B5814PAP5311
CHECKED	KARTHIK	06/03/15	
ENGR	VENA	06/03/15	
W/C			
QUALITY	TEJASNI	06/03/15	SCALE: 0.500 REF. No.: 4002B5814PAP5301
ISSUED			SHEET 1 OF 1

Marks:

Connection Diagram
GEM2034E-FIG1



End shield Assembly		
Part Description	DE Side Part#	ODE Side Part#
End Shield	4004D5280PB1	4004D5280SG1
Bearing	235A2600AA01	235A2600AA01
Slinger/Inproseal	4002B5914AF1	4002B5914AG1

Fan & Fan Cover Assembly	
Part Description	Part#
Fan	4001A5914AM-G01
Fan Cover	4003C5785PA1

Conduit & Accessories Box Assembly	
Part Description	Part#
Conduit Box	4002B5718PA-G01

Mechanical Accessories	
Part Description	Part#
Brake	
Tachometer	