

Product Information Packet

April 26, 2017

Data shown is for the current revision model #. Ensure your nameplate model # matches.

Model Number:	5KS444DAJ6023A
Catalog Number:	V4556
Instruction Manual:	GEK-95352
Connection Diagram:	GEM2034E-FIG7
Outline Drawing:	148CB44VMHKCCLA0001

Accessory Connection Diagrams			
Bearing Thermocouple:	None	Heater:	3027JE-1C
RTD:	None	Thermistor:	None
Thermostat:	3027JE-2A	Winding Thermocouple:	None
Bearing RTD:	None		

Table of Contents

Specification	01
Performance Characteristics	02
Outline Drawing	03
Connection Drawing(s)	04
Spare parts	05



Marks:

MODEL NUMBER:	5KS444DAJ6023A	Estimated Weight:	2450 Lbs
Outline Drawing:	148CB44VMHKCCLA0001	Time Rating:	CONT
Connection Diagram:	GEM2034E-FIG7	Enclosure:	WPI
Instruction Book:	GEK-95352	Encl Construction:	OPEN
Design Code:	44BD1165BA	Ambient Max(°C):	40
Type:	KS	Alt Ambient Max(°C):	--
Frame:	L444TP16	Insulation Class:	H
Phases:	3	NEMA Design:	B
Poles:	4	Nominal Efficiency:	95.8 %
Output Power:	150HP 111KW	Guaranteed Efficiency:	95.0
RPM:	1785	3/4 Load Efficiency:	95.9
Voltage:	575	KVA Code:	G
Hertz:	60	Max KVAR:	54.4
Amps - FL:	142.0	Power Factor:	82.5
Service Factor:	1.15	Bearing - DE:	6217C3
Alt Service Factor:	--	Bearing - ODE:	235A2536AB01

Enclosure is Weather Protected One

Stamped Nameplate Notes:

HTR LDS HE1-HE2 115V 145W
 ROT CCW FACING ODE LEAD/PH SEQ 1-2-3/1-2-3
 THERMOSTAT LEADS TB1-TB2 TRIP
 INVERTER DUTY PER NEMA MG1 PART 31
 ALTERNATE RATING FOR PWM CONTROL:1.0SF 40C AMBIENT
 VAR TORQUE RANGE 5-60 HZ

Additional Information:

4 POLE,VERT HOLLOW SHAFT HIGH THRUST (1D)
 SPECIAL BALANCE
 700 CU IN - 3.00" NPT
 BEARING LIFE 8760 HRS AT 13500 LB THRUST
 C/B GRD PLATE
 OIL RESISTANT SLEEVING ON LEADS
 N.C. TRIP TSTAT LDS TO MAIN CONDUIT BOX
 115V HTR LDS TO MAIN CONDUIT BOX
 COUPLING NOT INCLUDED IN BOM, WILL BE
 ORDERED SEPERATELY
 AEGIS GROUNDING RING MOUNTED ON LOWER END BEARING CAP
 GROUND PAD ON FRAME
 INSULATED LOWER HALF COUPLING

Performance Characteristics

1st Winding 1st Connection

Design: 44BD1165BA

Marks:

LOAD %	125.0	115.0	100.0	75.0	50.0	25.0	0.0
% EFF	94.9	95.04	95.4	95.2	94.53	91.41	0.00
% PF	84.6	83.93	82.36	77.44	66.87	44.24	3.84
AMPS	174.86	161.91	142.93	114.25	88.84	69.43	60.65

TORQ(FL)#FT	441.32	TORQ(LR)%FL	177.33	TORQ(BD)%FL	279.85
AMPS(LR)	876.33	PF AT START	0.31		

This motor is capable of two cold or one hot start with a maximum connected load inertia of 2466 Lb-Ft Sq (103.82 Kg-meter Sq) at 100% voltage, where the load torque varies with the square of the speed. Acceleration time with maximum inertia and the above load type is 25 seconds. Safe stall time at 100% voltage is 46 seconds cold, 30 seconds hot. Rotor inertia is 44.5 Lb-Ft Sq (1.87 Kg-meter Sq).

Open Circuit A-C:	0.675	Short Circuit D-C:	0.03
Short Circuit A-C:	0.043	X/R Ratio:	11.173
Stator Slots:	72	Rotor Slots:	58

Speed Torque Current Curve (First Connection, First Speed)

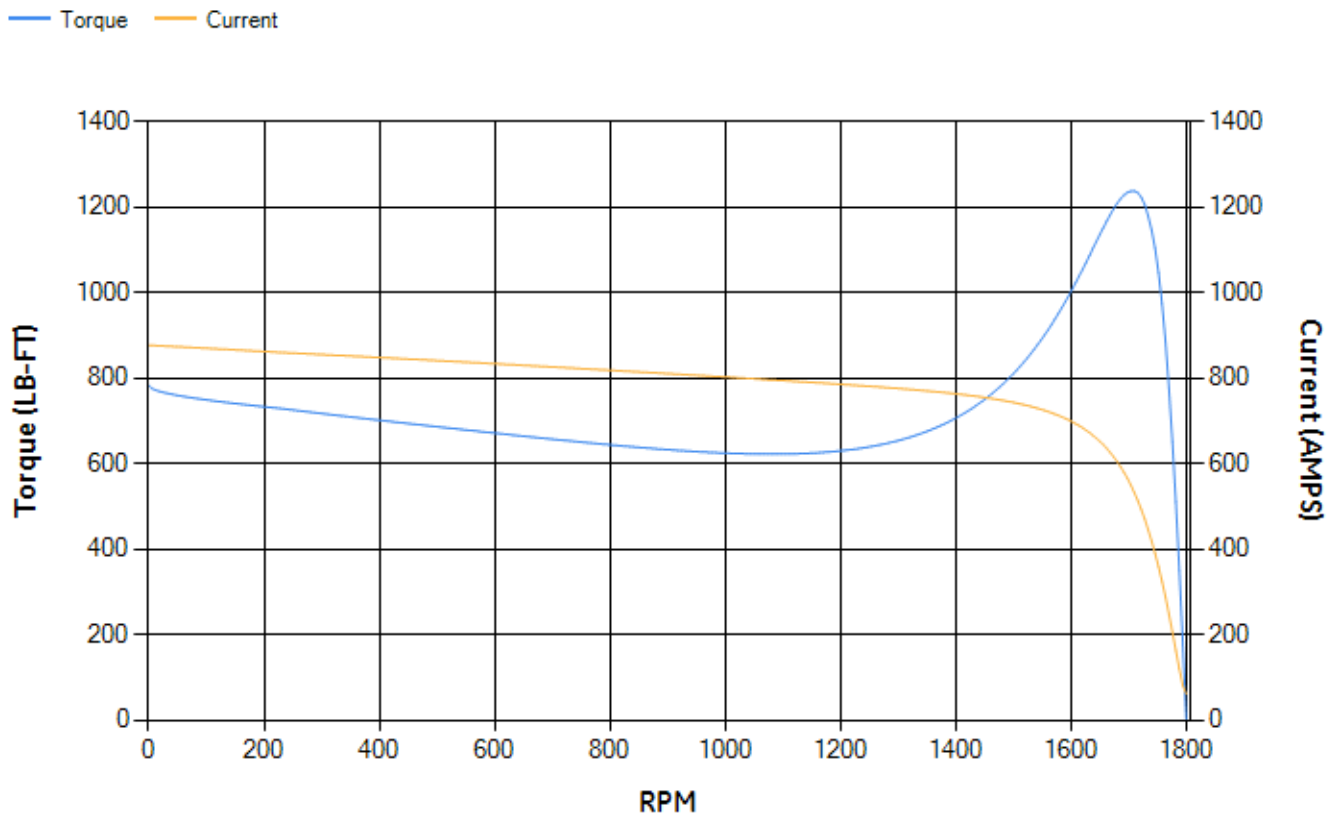

Marks:

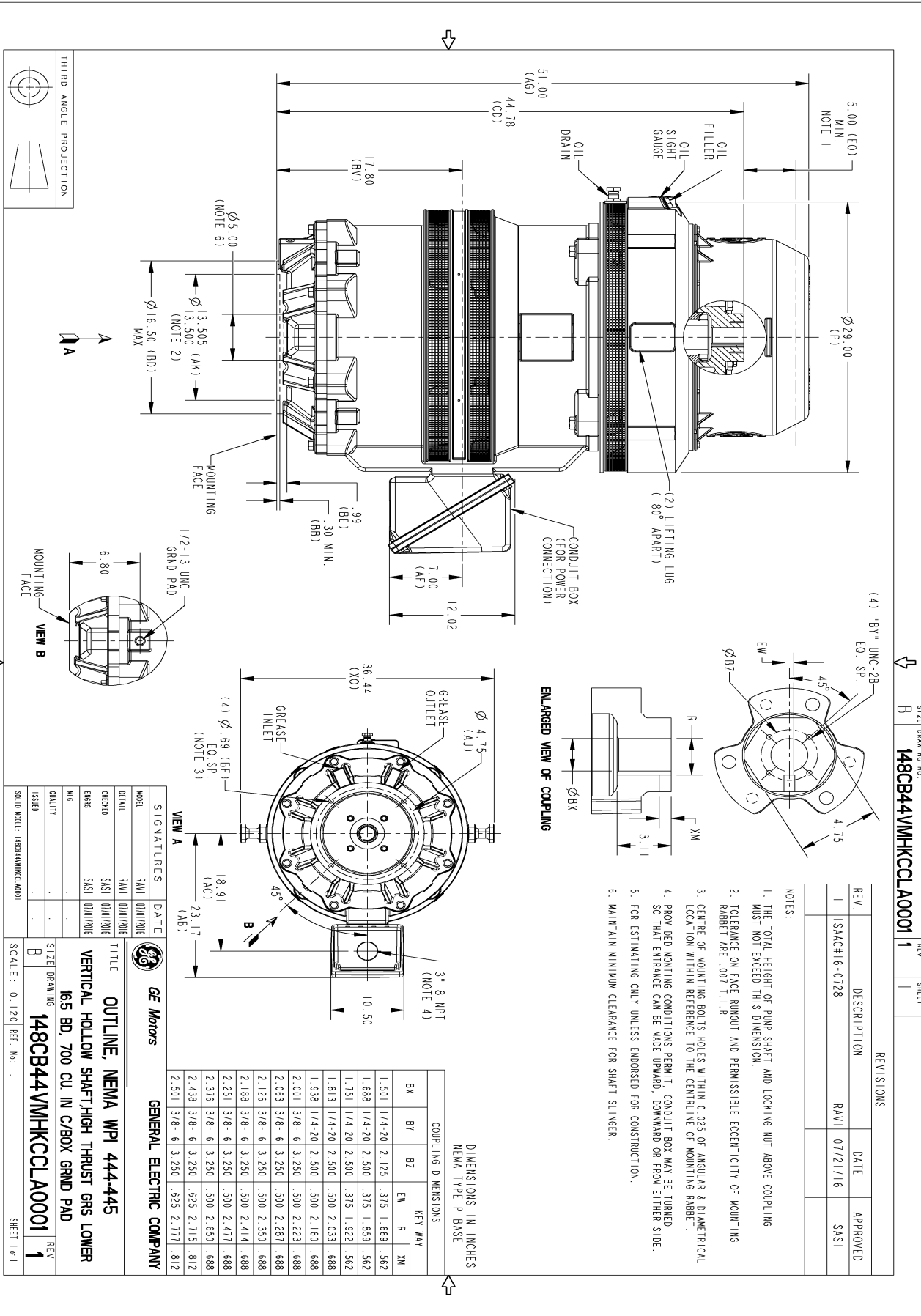

Marks:

Connection Diagram
GEM2034E-FIG7

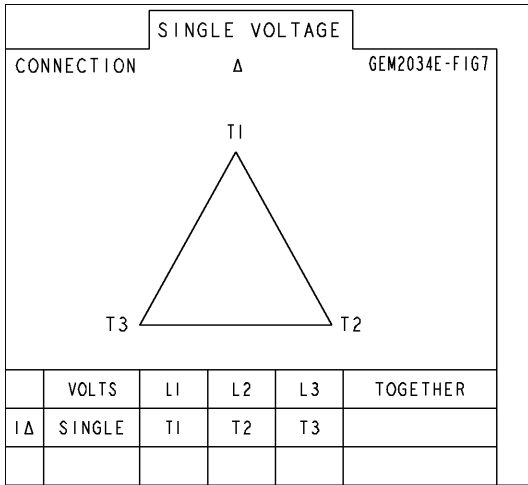

Heater Connection
3027JE-1C

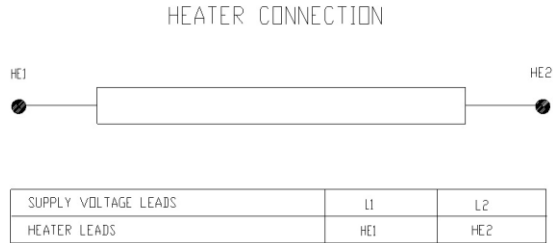

Thermostat Connection
3027JE-2A

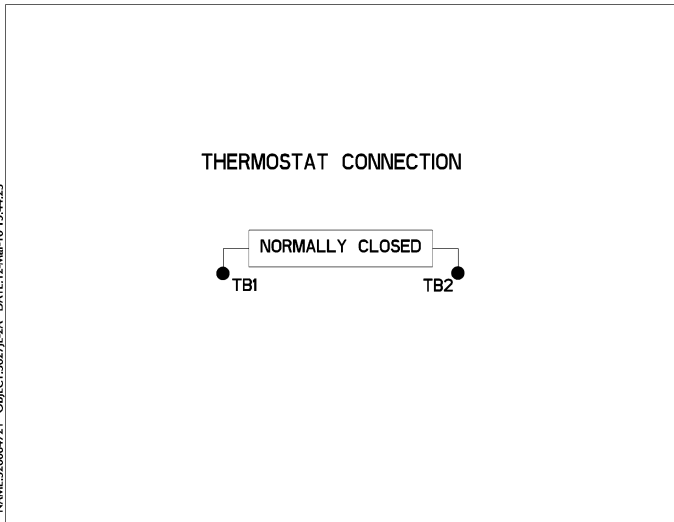

End shield Assembly		
Part Description	DE Side Part#	ODE Side Part#
End Shield	115E7660AA1	115E7670LA1
Bearing	235A2522AJ01	235A2536AB01
Slinger/Inproseal		

Fan & Fan Cover Assembly	
Part Description	Part#
Fan	
Fan Cover	149C4050AA1

Conduit & Accessories Box Assembly	
Part Description	Part#
Conduit Box	118D4408AD2

Mechanical Accessories	
Part Description	Part#
Brake	
Tachometer	