

Product Information Packet

November 7, 2016

Data shown is for the current revision model #. Ensure your nameplate model # matches.

Model Number:	5KS254ATE205A
Catalog Number:	E732
Instruction Manual:	GEI-M1023
Connection Diagram:	GEM2034E-FIG10
Outline Drawing:	358B6216AA

Accessory Connection Diagrams			
Bearing Thermocouple:	None	Heater:	None
RTD:	None	Thermistor:	None
Thermostat:	None	Winding Thermocouple:	None
Bearing RTD:	None		

Table of Contents	
Specification	01
Performance Characteristics	02
Outline Drawing	03
Connection Drawing(s)	04



Marks:

MODEL NUMBER:	5KS254ATE205A	Estimated Weight:	230 Lbs
Outline Drawing:	358B6216AA	Time Rating:	CONT
Connection Diagram:	GEM2034E-FIG10	Enclosure:	DP
Instruction Book:	GEI-M1023	Encl Construction:	OPEN
Design Code:	25AD1007A	Ambient Max(°C):	40
Type:	KS	Alt Ambient Max(°C):	--
Frame:	254T	Insulation Class:	F
Phases:	3	NEMA Design:	A
Poles:	4	Nominal Efficiency:	93 %
Output Power:	15HP 11.1KW	Guaranteed Efficiency:	91.7
RPM:	1765	3/4 Load Efficiency:	93.3
Voltage:	230/460	KVA Code:	H
Hertz:	60	Max KVAR:	5.3
Amps - FL:	37.2/18.6	Power Factor:	81
Service Factor:	1.15	Bearing - DE:	6310ZZ
Alt Service Factor:	--	Bearing - ODE:	6208ZZ

Enclosure is Dripproof

Stamped Nameplate Notes:**Additional Information:**

4 POLE DP
 LRA: 254.8/127.4
 NO. OF MOTOR LEADS: 12
 CONDUIT BOX VOLUME (IN³): 110.9
 CONDUIT BOX MTL: STAMPED STEEL
 GREASE TYPE: SHELL ALVANIA R3 LITHIUM GREASE
 USABLE AT 200V @ 15HP, 40.8 AMPS @ 1.0 SF
 50 HZ DATA: 15HP, 200/400V, 42.6/21.3 AMPS @ 1.0SF, 1460 RPM
 SOUND POWER: 74.1
 INVERTER DUTY PER NEMA MG1 PART 31
 FOR VARIABLE TORQUE LOADS

Performance Characteristics

1st Winding 1st Connection

Design: 25AD1007A

Marks:

LOAD %	125.0	115.0	100.0	75.0	50.0	25.0	0.0
% EFF	92.25	92.58	93.18	93.28	92.69	89.05	0.00
% PF	84.21	83.79	82.62	78.49	69.05	47.45	5.42
AMPS	22.59	20.81	18.24	14.38	10.97	8.31	7

TORQ(FL)#FT	44.48	TORQ(LR)%FL	273.08	TORQ(BD)%FL	275.98
AMPS(LR)	123.98	PF AT START	0.42		

This motor is capable of two cold or one hot start with a maximum connected load inertia of 583 Lb-Ft Sq (24.54 Kg-meter Sq)at 100% voltage, where the load torque varies with the square of the speed. Acceleration time with maximum inertia and the above load type is 40 seconds. Safe stall time at 100% voltage is 67 seconds cold, 62 seconds hot. Rotor inertia is 1.76 Lb-Ft Sq (0.07 Kg-meter Sq).

Open Circuit A-C:	0.41	Short Circuit D-C:	0.018
Short Circuit A-C:	0.02	X/R Ratio:	6.729
Stator Slots:	48	Rotor Slots:	40

Speed Torque Current Curve (First Connection, First Speed)

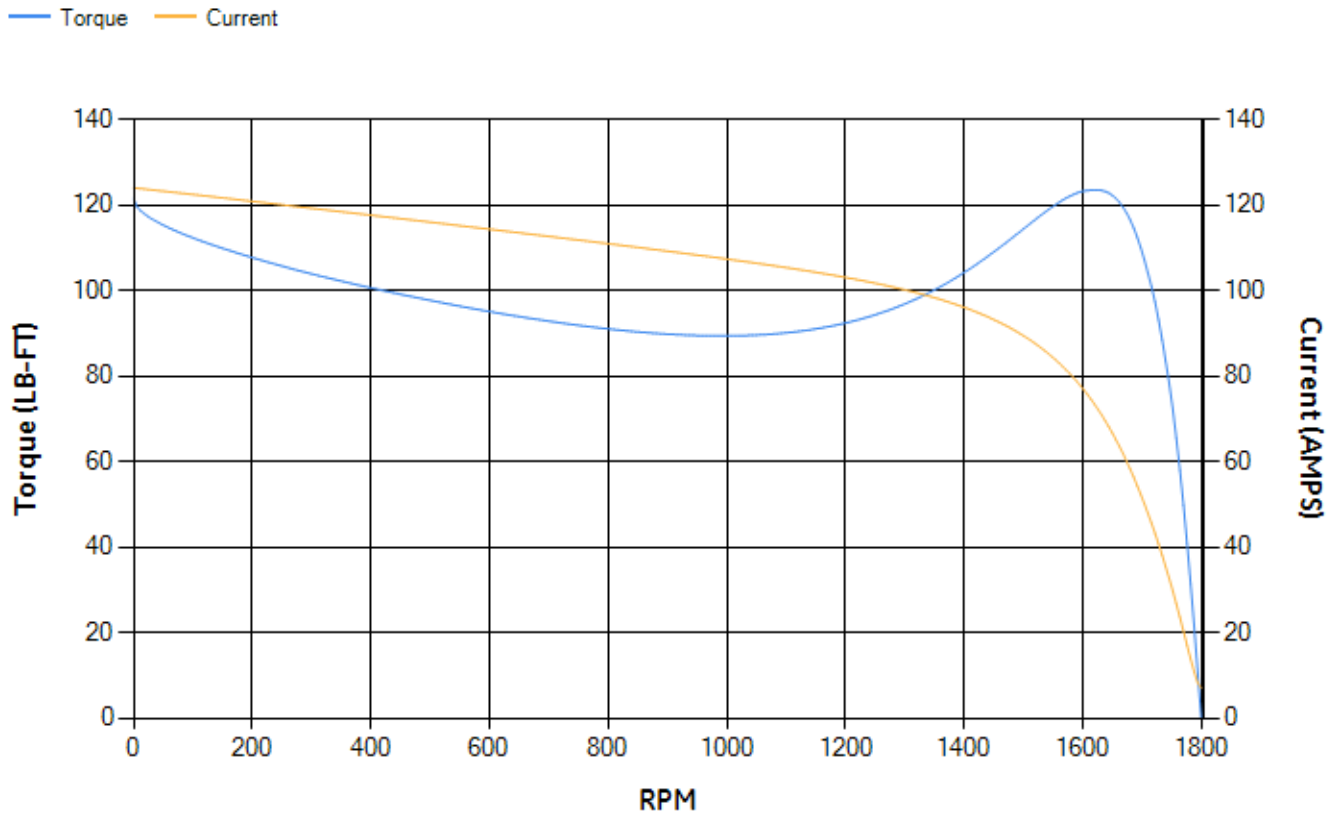

NAME:501452442 OBJECT:358B6216AA DATE:23-May-07 23:51:25

Marks:

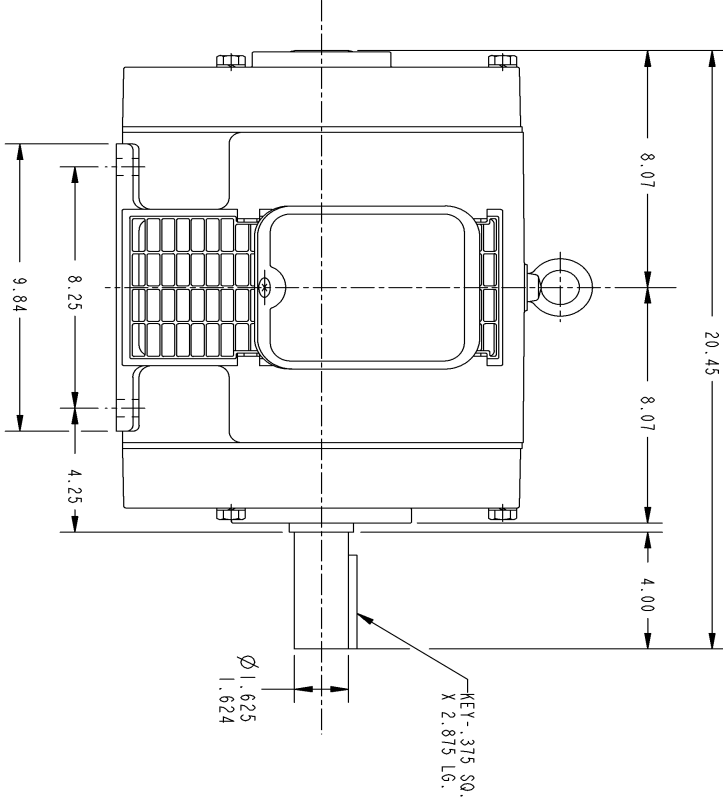
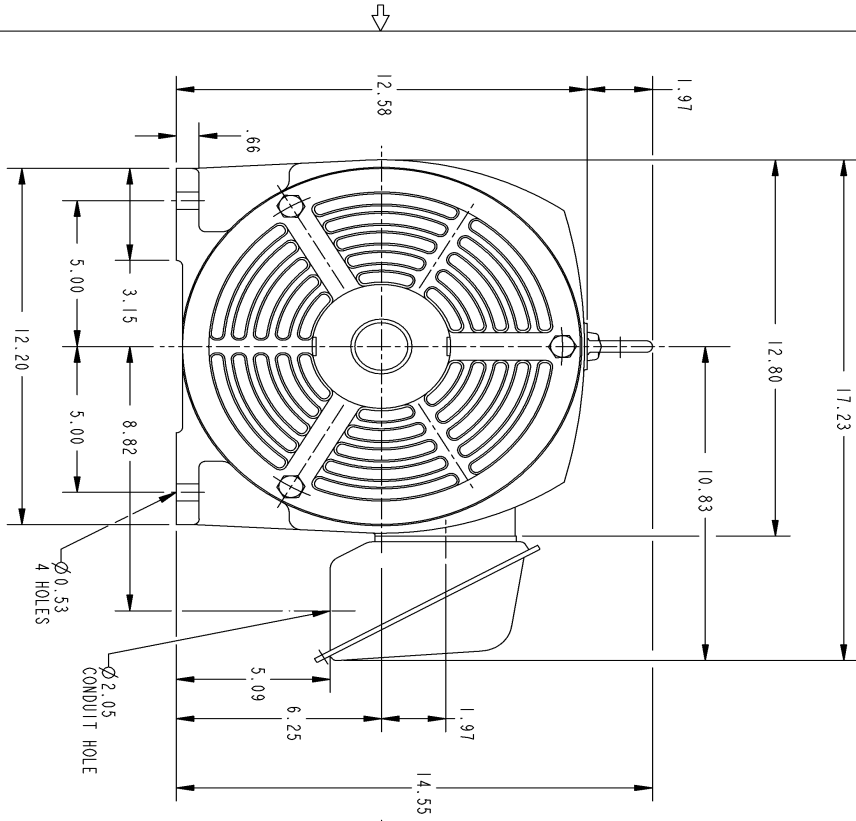

NOTES :

1. CONDUIT BOX MAY BE PLACED WITH THE ENTRANCE DOWN, UP OR ON EITHER SIDE.
2. F-1 ASM AS SHOWN.
3. F-2 ASM - HAS CONDUIT BOX ON OPPOSITE SIDE.

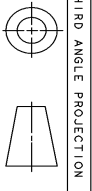

THIRD ANGLE PROJECTION

SIZE: **B** DRAWING FOR: **358B6216AA**
 GE PROPRIETARY INNOVATION

REV.	DESCRIPTION	DATE	APPROVED
1	ISAAC 07-0770	05/02/07	R. KOHNE

UNLESS OTHERWISE SPECIFIED:		SIGNATURES		DATE	
DIMENSIONS ARE IN INCHES		DRAWN		P. RAJU 03/27/03	
TOLERANCE ON:		CHECKED		PRABHAKAR 03/27/03	
2 PL DECIMALS ±		ENGRS			
3 PL DECIMALS ±		ISSUED		PRABHAKAR 03/27/03	
ANGLES ± 1°		APPLIED PRACTICES			
MATERIAL:		SIZE DRAWING		REV.	
		B		1	
SCALE: DRAWING SCALE		GENERAL ELECTRIC COMPANY		Fort Wayne, Indiana	
		Systems		OUTLINE	
		254T - OPEN DRIP PROOF		358B6216AA	
DISTRIBUTION:		SHEET 1 OF 1			

Marks:

Connection Diagram
GEM2034E-FIG10

