

Product Information Packet

January 13, 2017

Data shown is for the current revision model #. Ensure your nameplate model # matches.

Model Number:	5KS286DAE6040B
Catalog Number:	V4411
Instruction Manual:	GEK-95353
Connection Diagram:	GEM2034E-FIG9
Outline Drawing:	4002B5828NMP5216

Accessory Connection Diagrams			
Bearing Thermocouple:	None	Heater:	3027JE-1C
RTD:	None	Thermistor:	None
Thermostat:	None	Winding Thermocouple:	None
Bearing RTD:	None		

Table of Contents

Specification	01
Performance Characteristics	02
Outline Drawing	03
Connection Drawing(s)	04
Spare parts	05



Marks:

MODEL NUMBER:	5KS286DAE6040B	Estimated Weight:	470 Lbs
Outline Drawing:	4002B5828NMP5216	Time Rating:	CONT
Connection Diagram:	GEM2034E-FIG9	Enclosure:	WPI
Instruction Book:	GEK-95353	Encl Construction:	OPEN
Design Code:	28BD1142A	Ambient Max(°C):	40
Type:	KS	Alt Ambient Max(°C):	--
Frame:	L286TP16	Insulation Class:	H
Phases:	3	NEMA Design:	A
Poles:	4	Nominal Efficiency:	94.1 %
Output Power:	30HP 22.2KW	Guaranteed Efficiency:	93.0
RPM:	1780	3/4 Load Efficiency:	94.3
Voltage:	230/460	KVA Code:	H
Hertz:	60	Max KVAR:	9.5
Amps - FL:	70.6/35.3	Power Factor:	84.5
Service Factor:	1.15	Bearing - DE:	7310
Alt Service Factor:	--	Bearing - ODE:	6210-2ZC3

Enclosure is Weather Protected One

Stamped Nameplate Notes:

PREMIUM EFFICIENT MOTOR
 NEMA ENCL WPI AND CSA ENCL DP
 ROT CCW FACING ODE LEAD/PH SEQUENCE 1-2-3/1-2-3
 HTR LDS HE1-HE2 115V 60W
 INVERTER DUTY PER NEMA MG1 PART 31
 ALTERNATE RATING FOR PWM CONTROL:
 1.0 SF VAR TORQUE RANGE 20-60 HZ
 SUITABLE FOR 25HP, 190/380V,
 50 HZ WITH 70.8/35.4AMPS AND 1480 RPM AT 1.0 SF

Additional Information:

4P - TP EXTN
 C/BOX 137 CU IN-1.50 NPT
 AUX LEADS EXIT WITH MOTOR LEADS
 RCF 5000 CPM, STATIC DEFLECTION .0014 INCHES &
 CENTER OF GRAVITY 12.00 INCHES
 HOLLOW SHAFT HIGH THRUST
 OIL RESISTANT SLEEVING ON LEADS
 BEARING LIFE 8760 HOURS AT 2960 LB THRUST
 BALL TYPE COUPLING
 COUPLING WILL BE ORDERED SEPARATELY
 DP STOCK 10/24/2016
 ENGINEERED BY: BALASUBRAMANIANH/BILURP

Performance Characteristics

1st Winding 1st Connection

Design: 28BD1142A

Marks:

LOAD %	125.0	115.0	100.0	75.0	50.0	25.0	0.0
% EFF	93.22	93.54	94.14	94.33	94.04	91.34	0.00
% PF	86.12	85.65	84.46	80.38	70.94	48.67	4.23
AMPS	43.72	40.3	35.29	27.77	21.04	15.79	13.31

TORQ(FL)#FT	88.41	TORQ(LR)%FL	211.29	TORQ(BD)%FL	313.5
AMPS(LR)	247.93	PF AT START	0.39		

This motor is capable of two cold or one hot start with a maximum connected load inertia of 973 Lb-Ft Sq (40.96 Kg-meter Sq) at 100% voltage, where the load torque varies with the square of the speed. Acceleration time with maximum inertia and the above load type is 44 seconds. Safe stall time at 100% voltage is 83 seconds cold, 68 seconds hot. Rotor inertia is 5.44 Lb-Ft Sq (0.23 Kg-meter Sq).

Open Circuit A-C:	0.661	Short Circuit D-C:	0.016
Short Circuit A-C:	0.028	X/R Ratio:	5.917
Stator Slots:	48	Rotor Slots:	40

Speed Torque Current Curve (First Connection, First Speed)

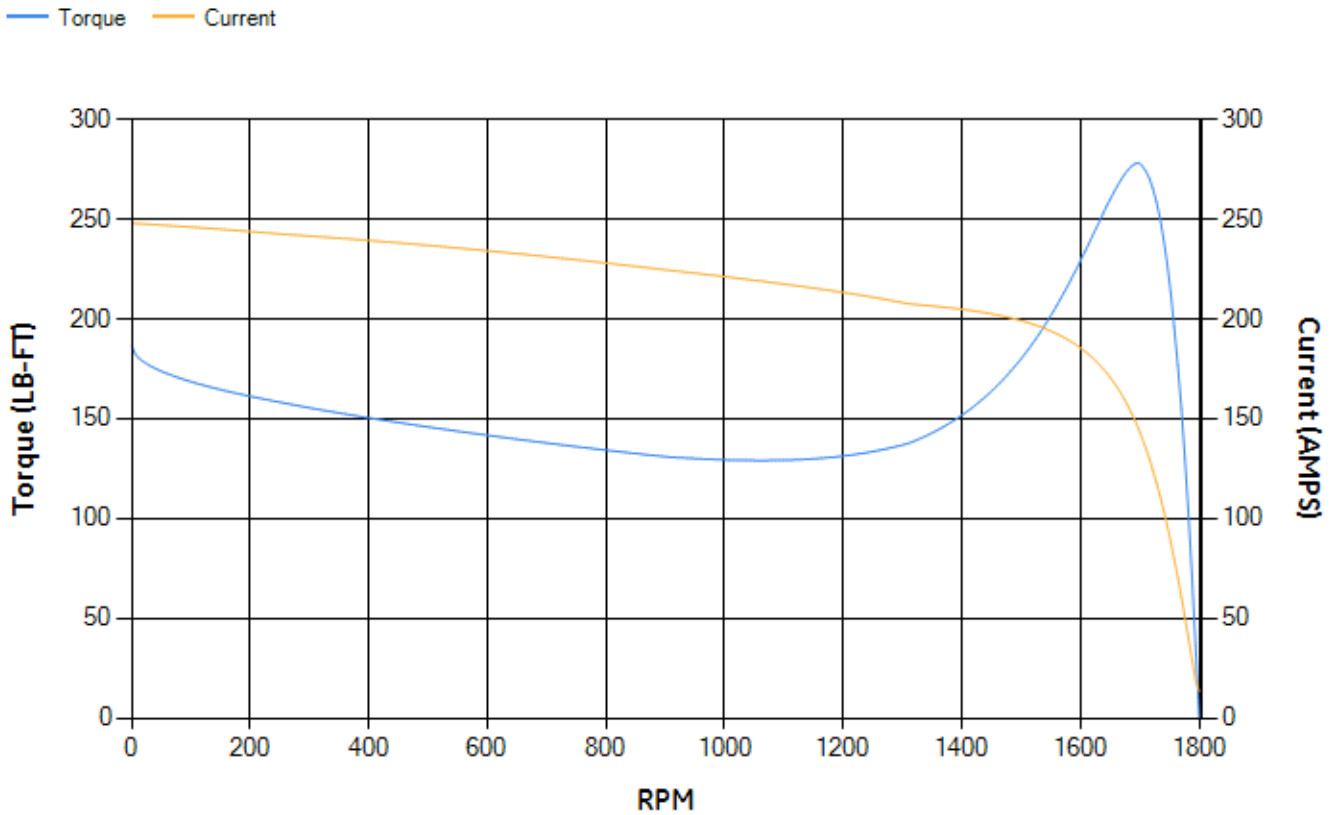

Marks:

SOLID MODEL: MODEL NAME

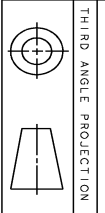

THIRD ANGLE PROJECTION

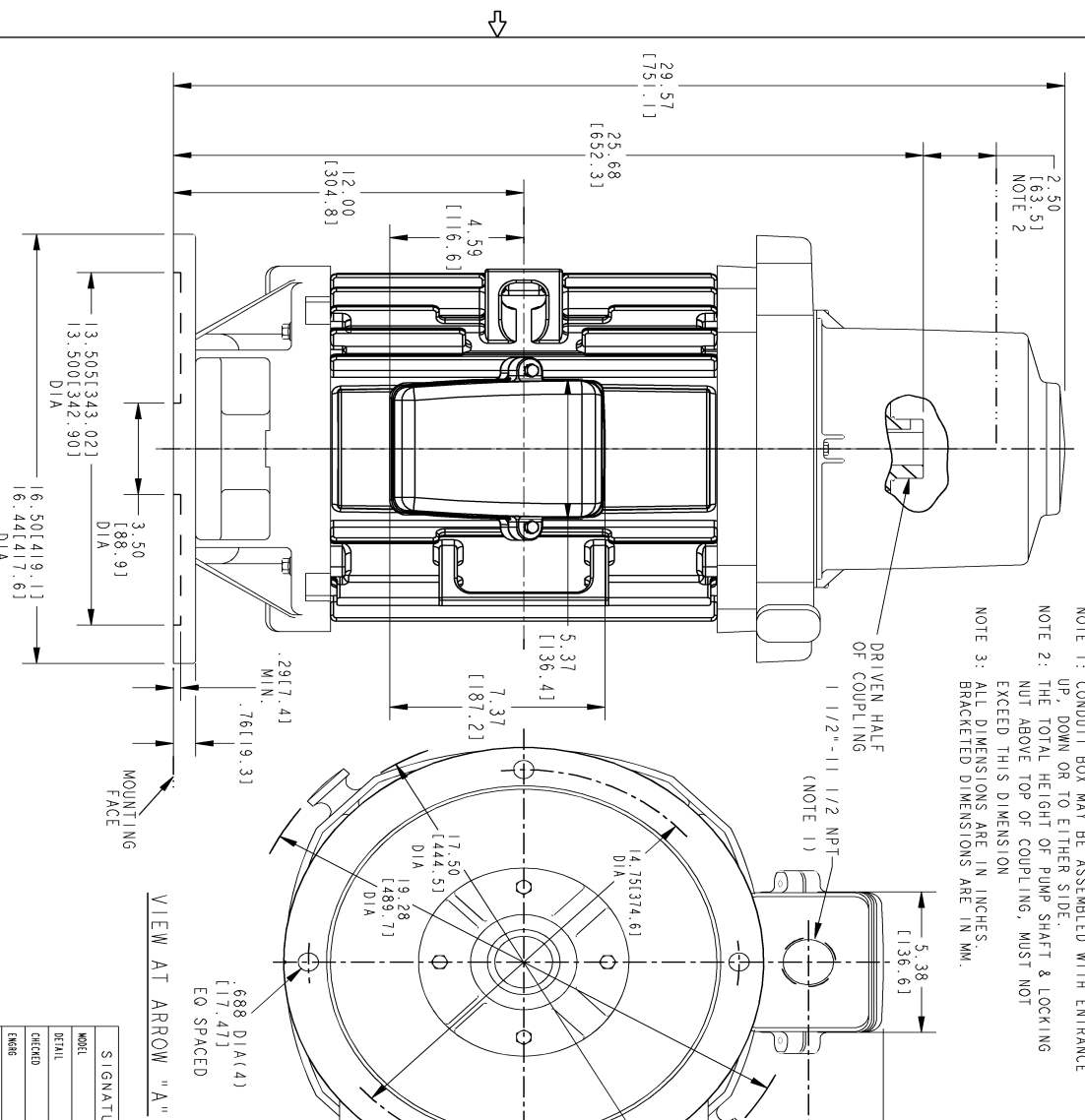

NOTE 1: CONDUIT BOX MAY BE ASSEMBLED WITH ENTRANCE UP, DOWN OR TO EITHER SIDE.
 NOTE 2: THE TOTAL HEIGHT OF PUMP SHAFT & LOCKING NUT ABOVE TOP OF COUPLING, MUST NOT EXCEED THIS DIMENSION
 NOTE 3: ALL DIMENSIONS ARE IN INCHES. BRACKETED DIMENSIONS ARE IN MM.

VIEW AT ARROW "A"

DRIVEN HALF OF COUPLING
 DIMENSIONS IN TABLE ARE IN INCHES

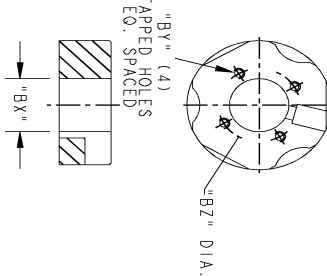

COUPLING KIT	GR. No.	"BY"	"BX"	BORE DIA. "BX"	KEYWAY "W" "D"
4002B55254A	1	1/4-20	1.750	1.252	1.251
	2	1/4-20	1.750	1.189	1.188
4002B55254A NON-REVERSE	3	#10-32	1.375	1.002	1.001
	4	#10-32	1.375	.877	.876
4002B55254B BOLTED OR SELF-RELEASE	5	1/4-20	1.750	.752	.751
	6	1/4-20	1.750	1.292	1.291
	7	1/4-20	1.750	1.251	1.250

REV.	DESCRIPTION	DATE	APPROVED
1	ISAC#13-0028	01/10/13	VIJAYT
2	ISAC#15-0305	03/31/15	PIYUSH
3	ISAC#16-1202	12/09/16	KARTHIK

GE POWER CONVERSION

INDUCTION MOTOR OUTLINE
 FR290 WP-1 STANDARD TP BASE VERTICAL
 HOLLOW SHAFT - HIGH THRUST (BD-3B)

4002B5528NMP5216 003

SCALE: .25

SHEET 1 OF 1

SIZE DRAWING NO. 4002B5528NMP5216 003

REV SHEET 1

Marks:

Connection Diagram
GEM2034E-FIG9

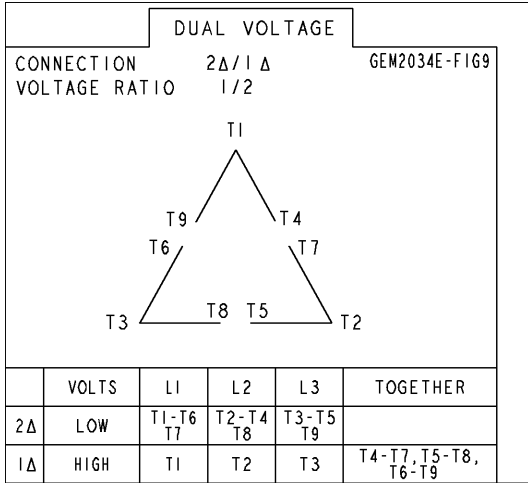

Heater Connection
3027JE-1C



End shield Assembly		
Part Description	DE Side Part#	ODE Side Part#
End Shield	128D6226PA1	128D6228PA1
Bearing	235A2508ET01	235A2508AK01
Slinger/Inproseal	235A2300FL2	

Fan & Fan Cover Assembly	
Part Description	Part#
Fan	
Fan Cover	

Conduit & Accessories Box Assembly	
Part Description	Part#
Conduit Box	4002B5728PA-G01

Mechanical Accessories	
Part Description	Part#
Brake	
Tachometer	