

TYPE	OUTPUT		POLE	TIME RATING CDNT.	VOLTAGE V	Hz	SYN SPEED R.P.M
	HP.	KW.					
ASHH	250	186.5	2		460	60	3600

DRIP PROOF TYPE, SQUIRREL-CAGE ROTOR

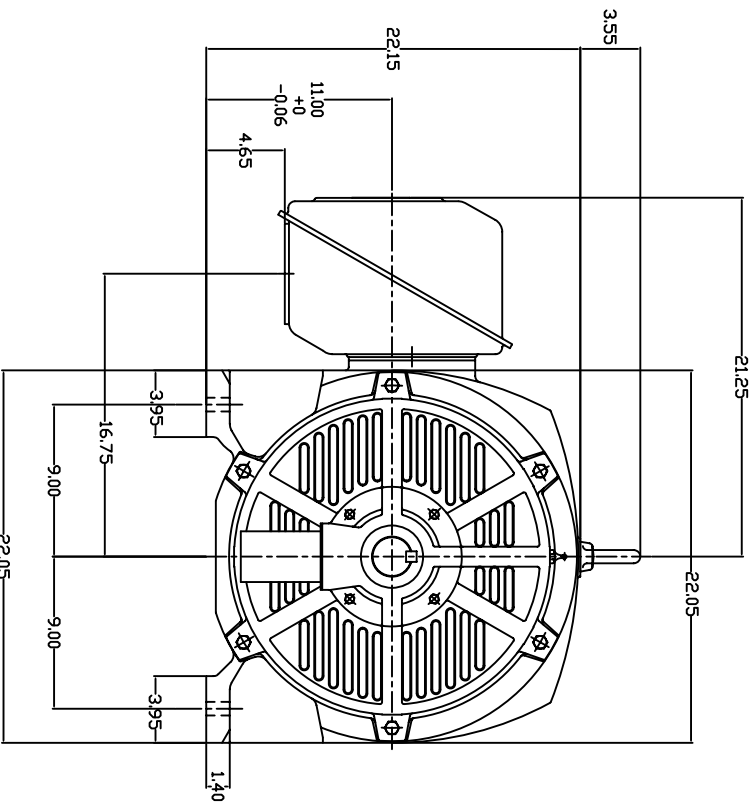
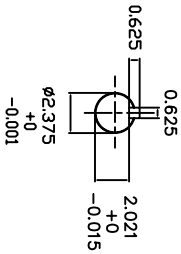
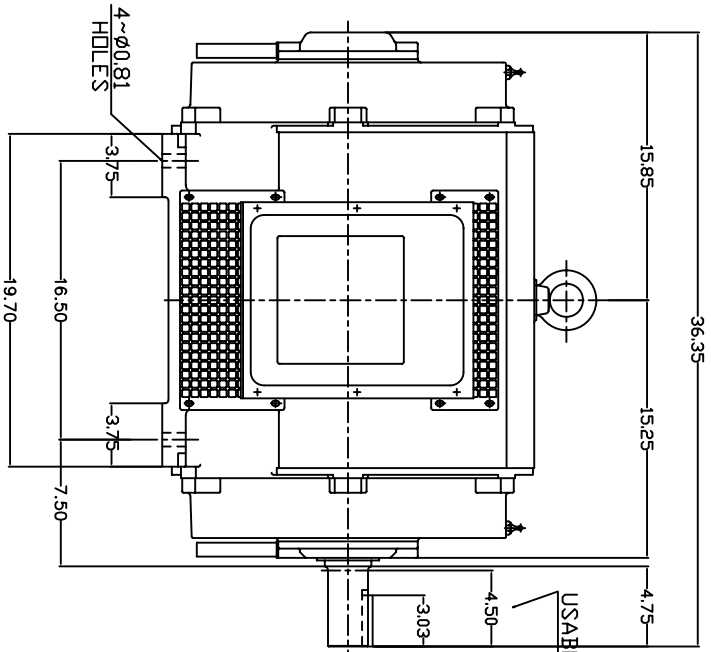

NOTE:

1. DIMENSIONS IN INCH.
2. FRAME NO. 445TS
3. F CLASS INSULATION, S.F. 115
4. FOR DIRECT FLEXIBLE COUPLING
5. BEARING SIZE: DRIVE END: 6314C3
NON-DRIVE END: 6314C3
6. MOTOR APPROX. WEIGHT: 1280 LBS

TB-56SC

DWN.	W.L.LIN	MAR. 26. 2003	DATE	February 24, 2007	OUTLINE DIMENSIONS
CHKD.	W.L.LIN	MAR. 26. 2003	CATALOG NO.	DHP2502	3-PHASE INDUCTION MOTOR
APPD.	C.WANG	MAR. 26. 2003			DWG NO. 3A040T260
					REV: 00