

TYPE	OUTPUT		POLE	TIME RATING	VOLTAGE	HZ	SYNSPEED R.P.M
	HP.	K.W.					
AEHGTK	400	298	8	CONT.	2300/4160	60	900

TOTALLY ENCLOSED FAN-COOLED TYPE. SQUIRREL-CAGE ROTOR

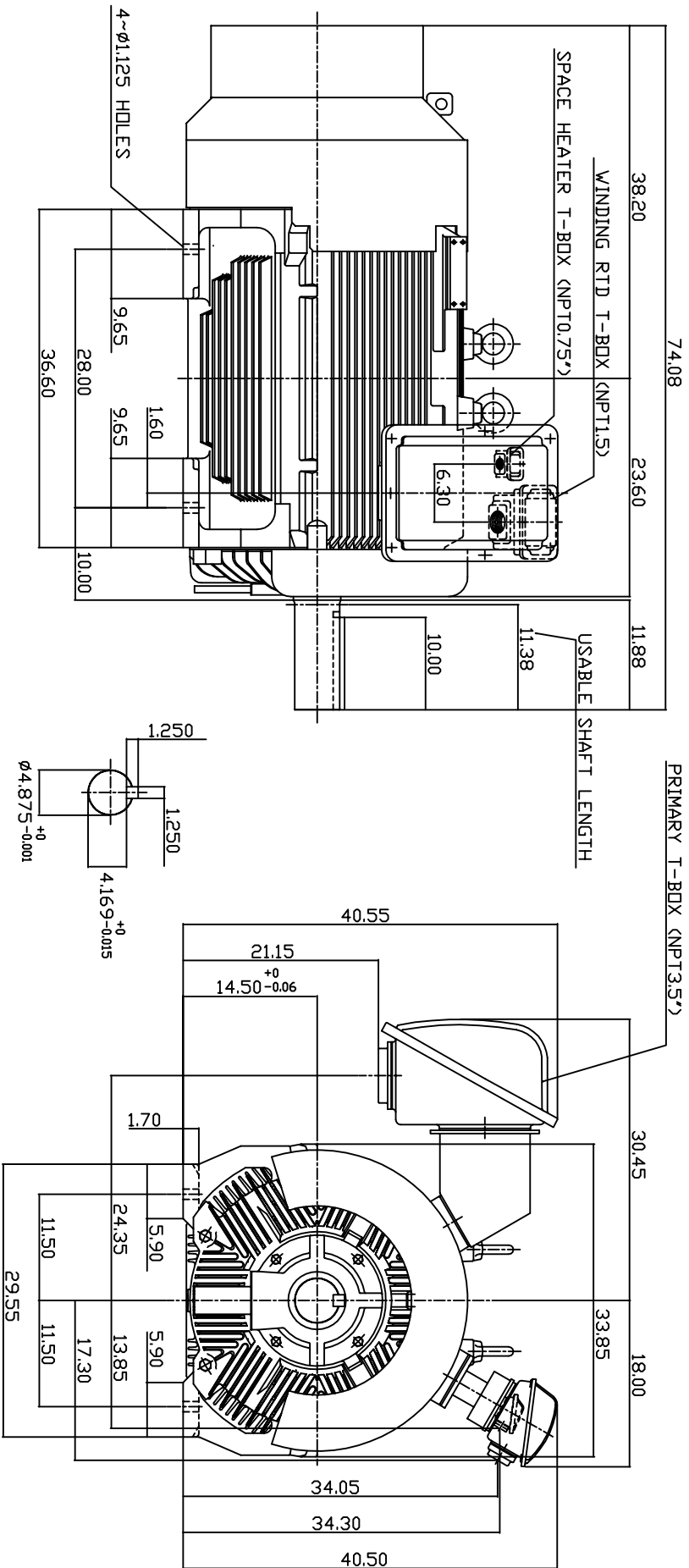

NOTE: 1. DIMENSIONS IN INCH.

2. FRAME NO. 5808C
3. F CLASS INSULATION, S.F.1.15
4. FOR BELT DRIVE APPLICATIONS
5. WITH SPACE HEATER 120 V/DLT SINGLE PHASE 200 WATTS
6. WITH 100 OHM PLATINUM WINDING RTD'S 2/PHASE
7. BEARING SIZE: DRIVE END: NU326 NON-DRIVE END: 6322
8. MOTOR APPROX. WEIGHT: 5300 LBS

TW-66C

DWN.	V.LLIN	DATE
CHKD.	V.LLIN	MAY-03-2003
APPD.	C.VANG	MAY-03-2003

DATE	OUTLINE DIMENSIONS
MAY 6, 2004	3-PHASE INDUCTION MOTOR
CATALOG NO. KG4008R	



DWG NO. 3A040T4581 REV: 00