

SHEET

REV

52A110181 3

SIZE DRAWING NO. A

THIRD ANGLE PROJECTION

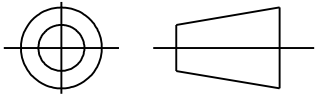

REVISIONS

REV.	DESCRIPTION	DATE	APPROVED
1	CHG TO RBC FORMAT PER IS05-1777	04/18/06	SUDHA
2	ADDED PART #3	01/17/07	MADHU
3	ADDED PART #4	01/21/09	DURGA

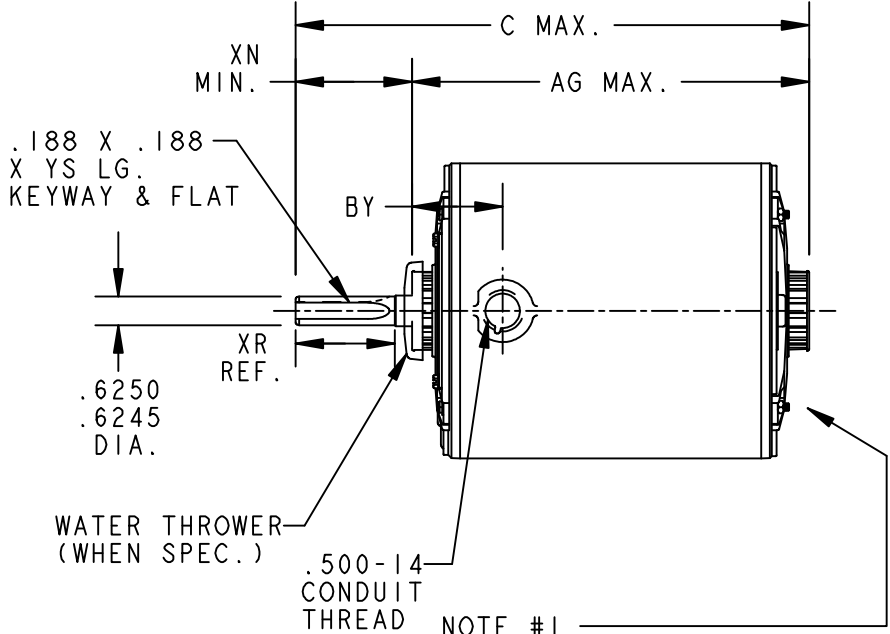
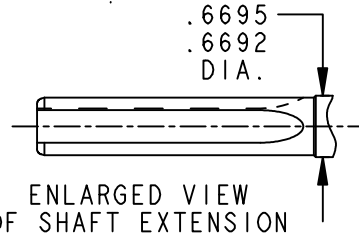
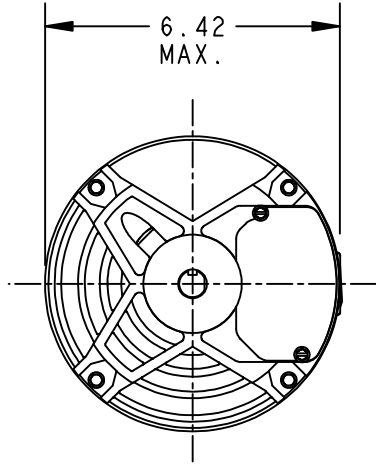

NOTE #1  
VENTILATION OPENINGS  
AROUND ENTIRE FACE OF  
NORMAL P.E. END SHIELD

P	TYPE	RBC SIZE	NEMA FR	XN	C	AG	REMARKS	SHELL LG.	BY	XR	YS
4	K	48	56Z	3.51	14.28	10.65	NOTE #1	8.43	2.07/1.95	3.25	2.12
3	K	49	56Z	6.00	15.49	9.37	NOTE #1	7.15	2.07/1.95	5.74	4.00
2	K	48	56Z	3.25	14.02	10.65	NOTE #1	8.43	2.07/1.95	2.99	2.26
1	K	49	56Z	2.05	14.02	11.85	NOTE #1	9.63	2.07/1.95	1.79	1.06

SIGNATURES		DATE	<p><b>REGAL-BELOIT CORPORATION</b></p> <p>TITLE</p> <p><b>OUTLINE</b></p> <p><b>40 FR. REDESIGN - OUTDOOR CONDENSOR -</b></p> <p><b>TENV (SE)- DRIP PROOF (PE) - BALL BEARING</b></p>
MODEL	M.D.PAPE	03/22/99	
DETAIL	.	.	
CHECKED	.	.	
ENGRG	.	.	
FOR ADDITIONAL INFO REFER TO:			SIZE DRAWING
APPLIED PRACTICES	QUALITY	.	52A110181
DIMENSIONS ARE IN INCHES	ISSUED	M.D.PAPE 03/22/99	REV 3
MATERIAL	SOLID MODEL: 52A110181		SCALE: 0.250 REF. No: . SHEET 1 of 1