

TYPE	OUTPUT		POLE	TIME RATING	VOLTAGE V	Hz	SYN.SPEED R.P.M
	HP.	kW.					
AEHGK	200	149.2	6	CONT.	2300/4160	60	1200

TOTALLY ENCLOSED FAN-COOLED TYPE, SQUIRREL-CAGE ROTOR

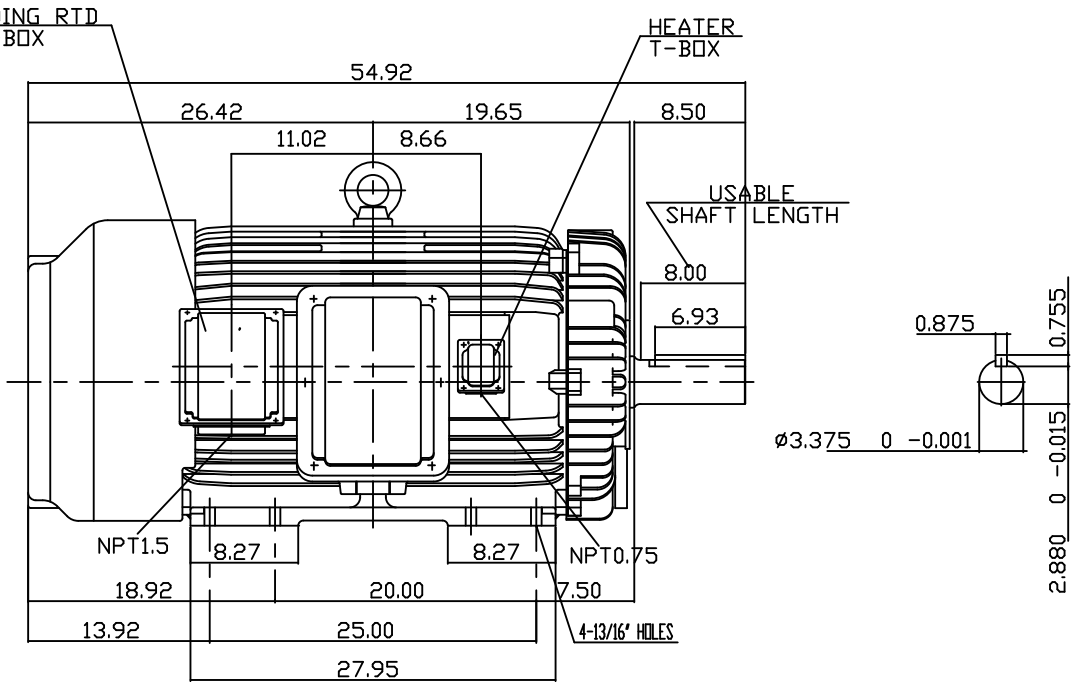
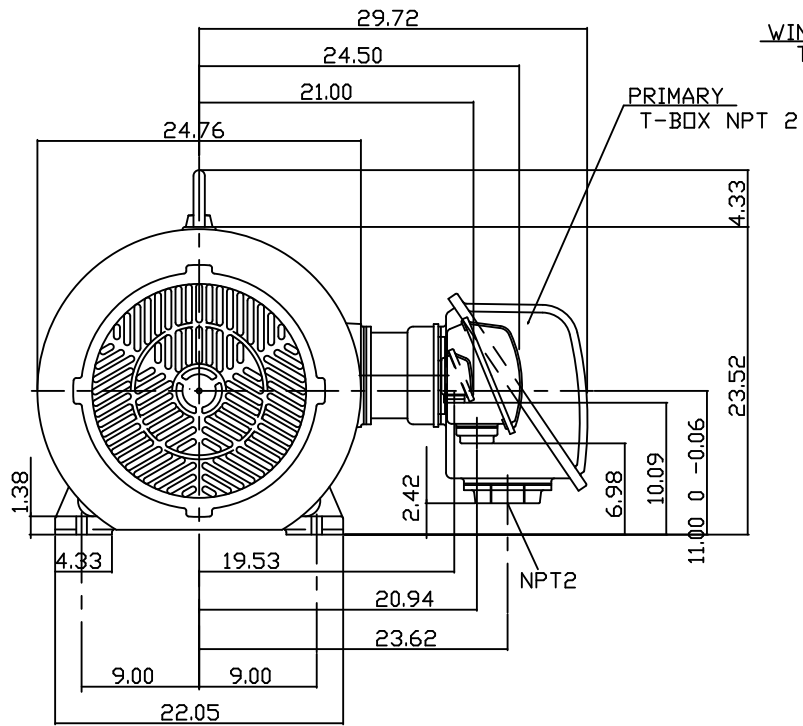

- NOTE:
1. DIMENSIONS IN INCH
 2. FRAME NO. 449T
 3. F CLASS INSULATION, S.F.1.15
 4. FOR DIRECT FLEXIBLE COUPLING
 5. 100 OHM PLATINUM WINDING RTD
 6. 120 VOLT SPACE HEATER AT 200 WATTS
 7. BEARING SIZE DRIVE END: 6320
NON-DRIVE END: 6316
 8. ENCLOSURE: IP54
 9. APPROX. WEIGHT: 2930 LBS

DATE: OCT 12, 2013	OUTLINE DIMENSIONS
CATALOG # KG2006T	3-PHASE INDUCTION MOTOR

DWN.	LKP	11-05-2013

TEC Westinghouse

DWG NO. REV: 00
3B040C101

TW-56C