

DATE  
FEB. 22, 2012  
CATALOG NO.  
GH1/52

OUTLINE DIMENSIONS  
3-PHASE INDUCTION MOTOR

MODEL TYPE:  
AEGH  
FRAME NO. 56

Pole	HP	KW	Hz	VOLT	Syn. Speed R. P. M
2	1.5	1.11	60	230/460	3600

Ins.	Rating	Dimensions in	Approx Weight	Bearings
F	CONT.	inch	30 lbs	DE: 6205ZZ NDE: 6204ZZ

Totally Enclosed Fan Cooled  
Squirrel-Cage

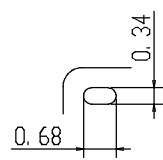
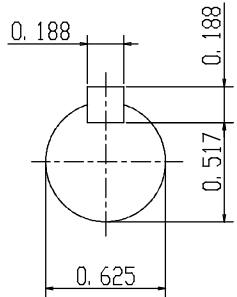
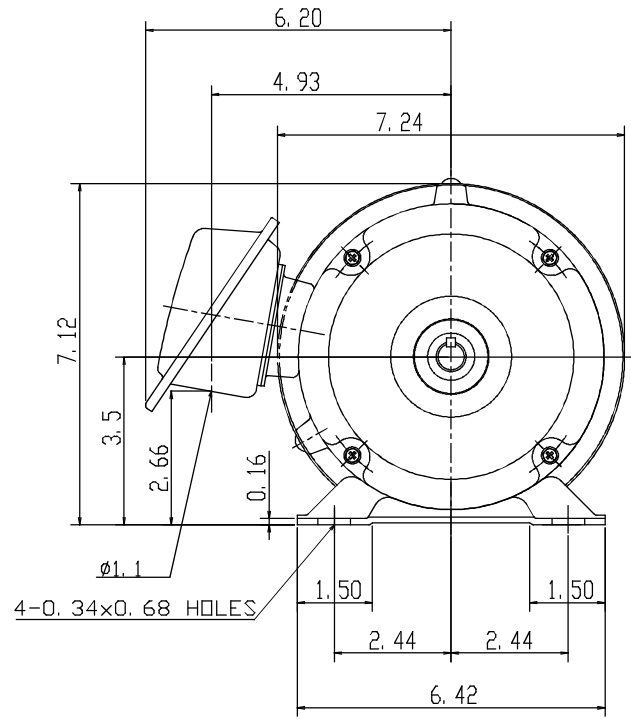
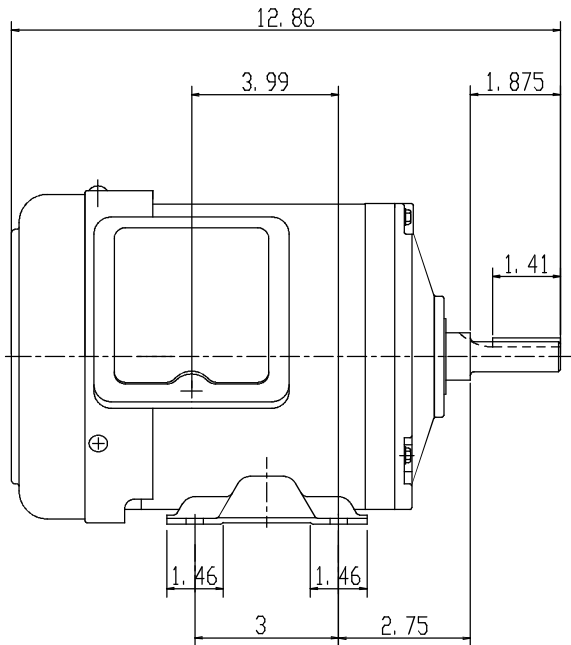

SCALE 4: 1

APPD.	W. H. TSAI	07 21 03
CHKD.	J. B. CHEN	07 20 03
DWN.	Y. Y. CHEN	07 20 03



DWG NO.  
31049Z105  
2204