

# Product Information Packet

November 8, 2016

Data shown is for the current revision model #. Ensure your nameplate model # matches.

<b>Model Number:</b>	<b>5KS326XAA1035C</b>
<b>Catalog Number:</b>	<b>M9561</b>
<b>Instruction Manual:</b>	GEI-56128
<b>Connection Diagram:</b>	GEM2034E-FIG7
<b>Outline Drawing:</b>	239C6001FS

<b>Accessory Connection Diagrams</b>			
<b>Bearing Thermocouple:</b>	None	<b>Heater:</b>	None
<b>RTD:</b>	None	<b>Thermistor:</b>	None
<b>Thermostat:</b>	None	<b>Winding Thermocouple:</b>	None
<b>Bearing RTD:</b>	None		

## Table of Contents

Specification	01
Performance Characteristics	02
Outline Drawing	03
Connection Drawing(s)	04
Spare parts	05



**Marks:**

<b>MODEL NUMBER:</b>	<b>5KS326XAA1035C</b>	<b>Estimated Weight:</b>	690 Lbs
<b>Outline Drawing:</b>	239C6001FS	<b>Time Rating:</b>	CONT
<b>Connection Diagram:</b>	GEM2034E-FIG7	<b>Enclosure:</b>	TEFC
<b>Instruction Book:</b>	GEI-56128	<b>Encl Construction:</b>	841
<b>Design Code:</b>	32BD0154B	<b>Ambient Max(°C):</b>	40
<b>Type:</b>	KS	<b>Alt Ambient Max(°C):</b>	--
<b>Frame:</b>	326TSC	<b>Insulation Class:</b>	H
<b>Phases:</b>	3	<b>NEMA Design:</b>	B
<b>Poles:</b>	2	<b>Nominal Efficiency:</b>	93.0 %
<b>Output Power:</b>	50HP 37KW	<b>Guaranteed Efficiency:</b>	92.4
<b>RPM:</b>	3565	<b>3/4 Load Efficiency:</b>	94.1
<b>Voltage:</b>	575	<b>KVA Code:</b>	G
<b>Hertz:</b>	60	<b>Max KVAR:</b>	14.2
<b>Amps - FL:</b>	46.3	<b>Power Factor:</b>	87.0
<b>Service Factor:</b>	1.15	<b>Bearing - DE:</b>	6312ZC3
<b>Alt Service Factor:</b>	--	<b>Bearing - ODE:</b>	6312ZC3

**Enclosure is Totally Enclosed Fan-Cooled**

**Stamped Nameplate Notes:**

IEEE-STD-841-2009  
 DE BRG 60BC03JP30, ODE BRG 60BC03JP30  
 STAMP NP249A5564P051 AS BELOW:  
 MODEL:5KS326XAA1035C S/N: XXX  
 CSA CERTIFIED CSA09.2216219 FOR EX NA IIC 200 C GC  
 CL 1 ZONE2 AEX NA IIC 200C;CL 1 DIV2 GRP ABCD 200C  
 IN -25C <= AMB <= 40C, 1.0 SF ON SINE-WAVE PWR  
 SURF TEMP 230C AT 1.15SF ON SINE-WAVE PWR  
 OR 200 C VT OR 230 C CT OR 200 C CHP PWM CONTROL  
 ALTERNATE RATING FOR PWM CONTROL 1.0SF 40C AMB  
 VT 0-60 HZ, CT 10-60 HZ, CHP 60-75 HZ.

**Additional Information:**

2P - TS EXTN  
 PAINTED FRAME ID & SHAFT,  
 FAN COVER INSIDE & ODE E/S OUTSIDE  
 C FACE ON DE  
 346 CU IN - 3.00" NPT  
 INPRO SEAL BOTH ENDS  
 OIL RESISTANT SLEEVING ON LEADS  
 .0015" TIR SHAFT RUNOUT  
 ROUTINE TEST REPORT AND 5 POINT VIBRATION TEST  
 REPORT INCLUDED IN C/B  
 COPPER WASHER UNDER HEADS OF BEARING CAP BOLTS,  
 APPLY TITE-SEAL (A50CD427A) ON BEARING CAP SCREWS,  
 RABBETS AND PLUG THREADS.  
 GROUND PAD

F1 MOUNTING

TEFC XSD-841 ULTRA STOCK 06/28/2016

ENGINEERED BY: BALASUBRAMANIANH/DHEERAJB



**Performance Characteristics**

1st Winding 1st Connection

**Design: 32BD0154B**

**Marks:**

LOAD %	125.0	115.0	100.0	75.0	50.0	25.0	0.0
% EFF	93.54	93.75	94.2	94.09	93.38	89.83	0.00
% PF	88.46	88.07	87.05	83.52	75.04	53.51	5.72
AMPS	56.55	52.14	45.6	35.73	26.71	19.47	15.89

TORQ(FL)#FT	73.6	TORQ(LR)%FL	175.09	TORQ(BD)%FL	296.52
AMPS(LR)	299.83	PF AT START	0.31		

This motor is capable of two cold or one hot start with a maximum connected load inertia of 156 Lb-Ft Sq (6.57 Kg-meter Sq)at 100% voltage, where the load torque varies with the square of the speed. Acceleration time with maximum inertia and the above load type is 21 seconds. Safe stall time at 100% voltage is 45 seconds cold, 25 seconds hot. Rotor inertia is 4.62 Lb-Ft Sq (0.19 Kg-meter Sq).

Open Circuit A-C:	0.797	Short Circuit D-C:	0.019
Short Circuit A-C:	0.04	X/R Ratio:	7.097
Stator Slots:	48	Rotor Slots:	38

**Speed Torque Current Curve (First Connection, First Speed)**

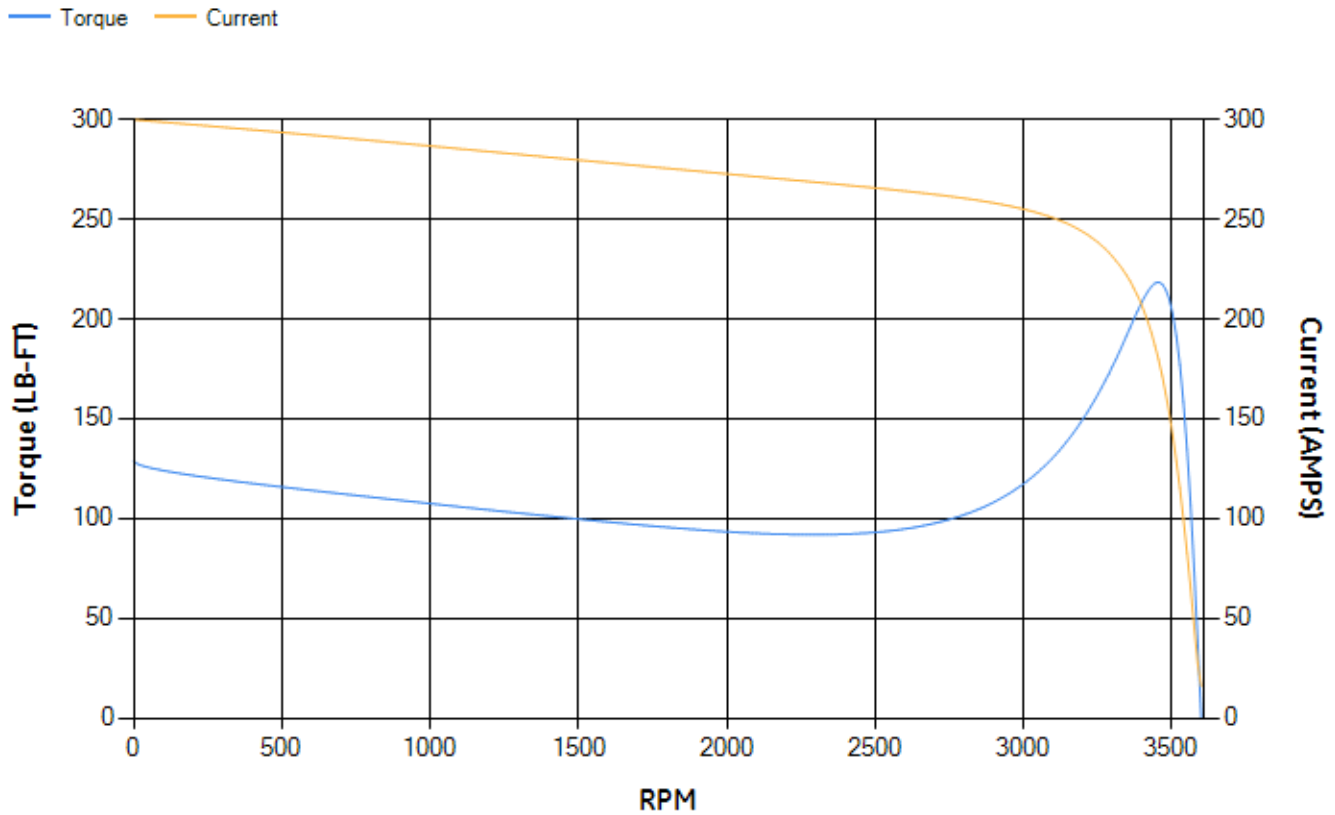

Marks:

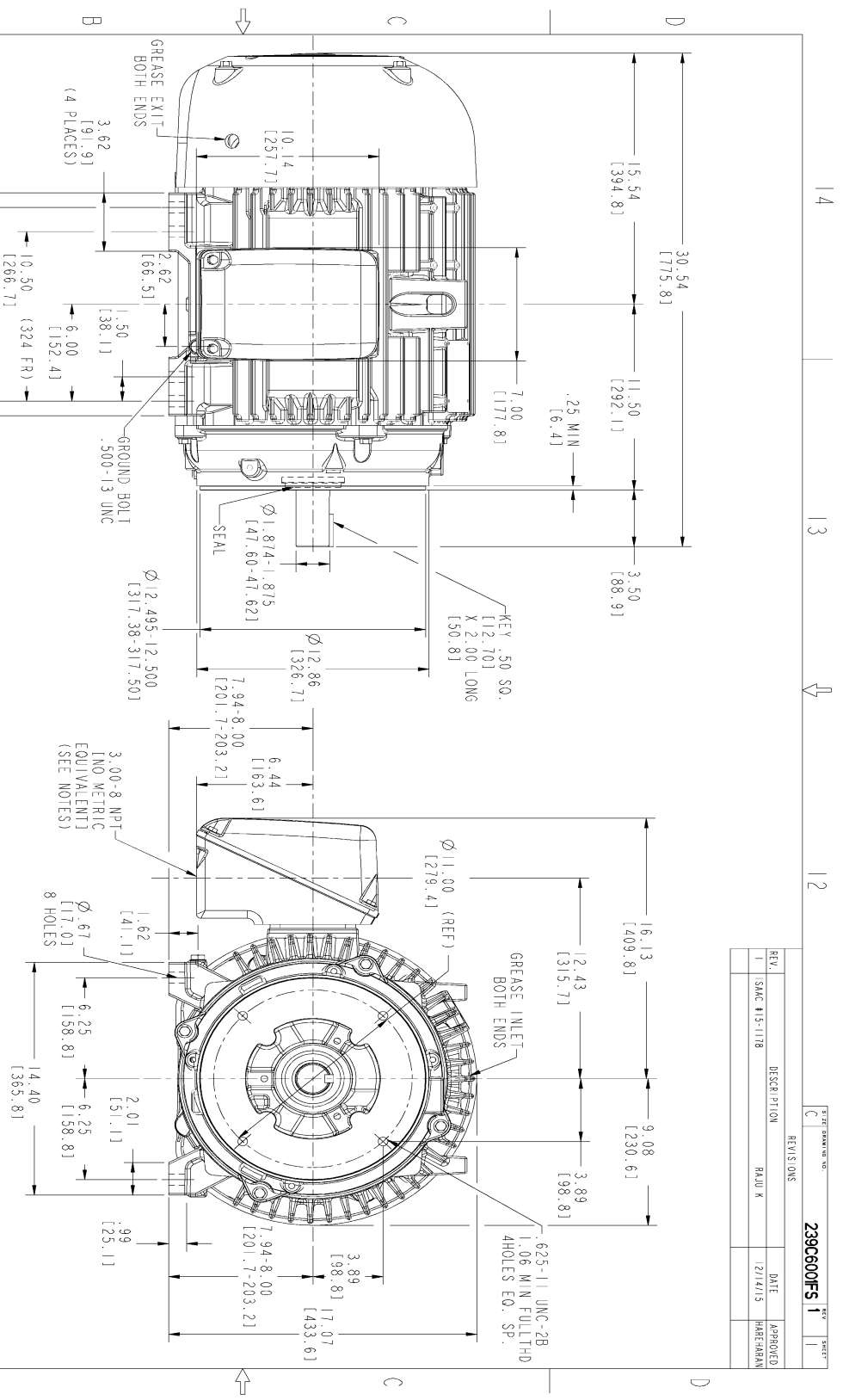

NOTES :

1. CONDUIT BOX MAY BE PLACED WITH THE ENTRANCE DOWN, UP OR ON EITHER SIDE.
2. F-1 ASM AS SHOWN.
3. F-2 ASM HAS CONDUIT BOX ON OPPOSITE SIDE.
4. BRACKETED DIMENSIONS ARE METRIC (MILLIMETERS).
5. TOLERANCE ON PERMISSIBLE SHAFT EXTENSION ROUNDOFF IS .0015 T.I.R.

SIZE DRAWING NO. <b>239C6001FS 1</b>		REV. <b>1</b>	SHEET <b>1</b>
REV. DESCRIPTION		DATE	APPROVED
1	SAC #15-1178 RAJUK	12/14/15	HAREHARAN

SIGNATURES		DATE	
MODEL	TEJASNI	06/26/15	
SCALE	TEJASNI	06/26/15	
TITLE			
GENERAL ELECTRIC COMPANY			
<b>OUTLINE</b>			
<b>324/326 TSC TFC XSD-941</b>			
<b>346 CU IN CONDUIT BOX</b>			
DRAWING		REV.	
SIZE	<b>C</b>	SHEET	<b>1</b>
SCALE	0.250	REF. NO.	239C6001 CR
SOLID MODEL: 239C6001FS		SHEET 1 OF 1	

Marks:

**Connection Diagram**  
**GEM2034E-FIG7**

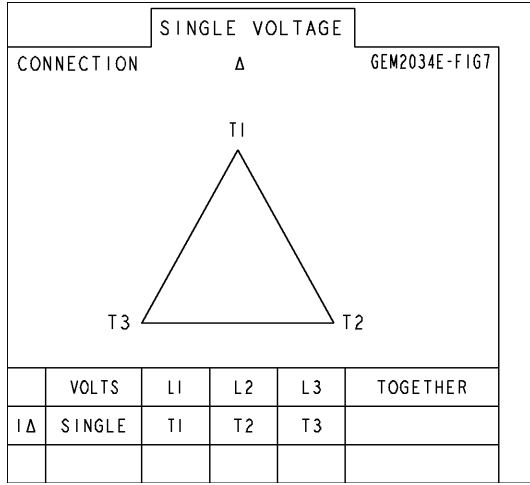

End shield Assembly		
Part Description	DE Side Part#	ODE Side Part#
End Shield	115E4203AA1	115E4200LA1
Bearing	235A2609AA01	235A2609AA01
Slinger/Inproseal	235A4575GS2	235A4575GS2

Fan & Fan Cover Assembly	
Part Description	Part#
Fan	159C6700G02
Fan Cover	128D6800AA1

Conduit & Accessories Box Assembly	
Part Description	Part#
Conduit Box	149C4429AA2

Mechanical Accessories	
Part Description	Part#
Brake	
Tachometer	