

Product Information Packet

November 9, 2016

Data shown is for the current revision model #. Ensure your nameplate model # matches.

Model Number:	5KS143SAA105D1
Catalog Number:	M486
Instruction Manual:	GEI-56128
Connection Diagram:	GEM2034E-FIG3
Outline Drawing:	4002B5814PAP5201

Accessory Connection Diagrams			
Bearing Thermocouple:	None	Heater:	None
RTD:	None	Thermistor:	None
Thermostat:	None	Winding Thermocouple:	None
Bearing RTD:	None		

Table of Contents

Specification	01
Performance Characteristics	02
Outline Drawing	03
Connection Drawing(s)	04
Spare parts	05



Marks:

MODEL NUMBER:	5KS143SAA105D1	Estimated Weight:	43 Lbs
Outline Drawing:	4002B5814PAP5201	Time Rating:	CONT
Connection Diagram:	GEM2034E-FIG3	Enclosure:	TEFC
Instruction Book:	GEI-56128	Encl Construction:	X\$D
Design Code:	14BD0040A	Ambient Max(°C):	40
Type:	KS	Alt Ambient Max(°C):	60
Frame:	143T	Insulation Class:	H
Phases:	3	NEMA Design:	B
Poles:	2	Nominal Efficiency:	84 %
Output Power:	1.5HP 1.1KW	Guaranteed Efficiency:	82.5
RPM:	3530	3/4 Load Efficiency:	83.9
Voltage:	230/460	KVA Code:	M
Hertz:	60	Max KVAR:	0.7
Amps - FL:	4.2/2.1	Power Factor:	79.0
Service Factor:	1.15	Bearing - DE:	6205ZC3
Alt Service Factor:	1.00	Bearing - ODE:	6205ZC3

Enclosure is Totally Enclosed Fan-Cooled

Stamped Nameplate Notes:

STAMP NP249A5564P051 AS BELOW:
 MODEL:5KS143SAA105D1 S/N: XXX
 CSA CERTIFIED CSA09.2216219 FOR EX NA IIC 200C GC
 CL 1 ZONE2 AEX NA IIC 200C;CL 1 DIV2 GRP ABCD 200C
 IN -40C <= AMB <= 40C, 1.0 SF ON SINE-WAVE PWR
 SURF TEMP 200C AT 1.15SF ON SINE-WAVE PWR
 OR 200 C VT OR 200 C CT OR 200 C CHP PWM CONTROL
 ALTERNATE RATING FOR PWM CONTROL 1.0SF 40C AMB
 VT 0-60 HZ, CT 3-60 HZ , CHP 60-90 HZ.

Additional Information:

2P - T EXTN
 STANDARD FLOOR MOUNT
 C/BOX 30 CU IN-0.75 NPT
 F1 CONDUIT BOX MOUNTING
 OIL RESISTANT SLEEVING ON LEADS

Performance Characteristics

1st Winding 1st Connection

Design: 14BD0040A

Marks:

LOAD %	125.0	115.0	100.0	75.0	50.0	25.0	0.0
% EFF	84.09	84.34	84.69	83.86	81.01	71.32	0.00
% PF	83.15	81.74	82.86	71.86	59.74	39.76	12.61
AMPS	2.51	2.34	1.98	1.75	1.45	1.24	0.96

TORQ(FL)#FT	2.23	TORQ(LR)%FL	328.21	TORQ(BD)%FL	443.75
AMPS(LR)	18.17	PF AT START	0.57		

This motor is capable of two cold or one hot start with a maximum connected load inertia of 12 Lb-Ft Sq (0.51 Kg-meter Sq)at 100% voltage, where the load torque varies with the square of the speed. Acceleration time with maximum inertia and the above load type is 23 seconds. Safe stall time at 100% voltage is 50 seconds cold, 38 seconds hot. Rotor inertia is 0.04 Lb-Ft Sq (0 Kg-meter Sq).

Open Circuit A-C:	0.256	Short Circuit D-C:	0.005
Short Circuit A-C:	0.01	X/R Ratio:	1.804
Stator Slots:	24	Rotor Slots:	34

Speed Torque Current Curve (First Connection, First Speed)

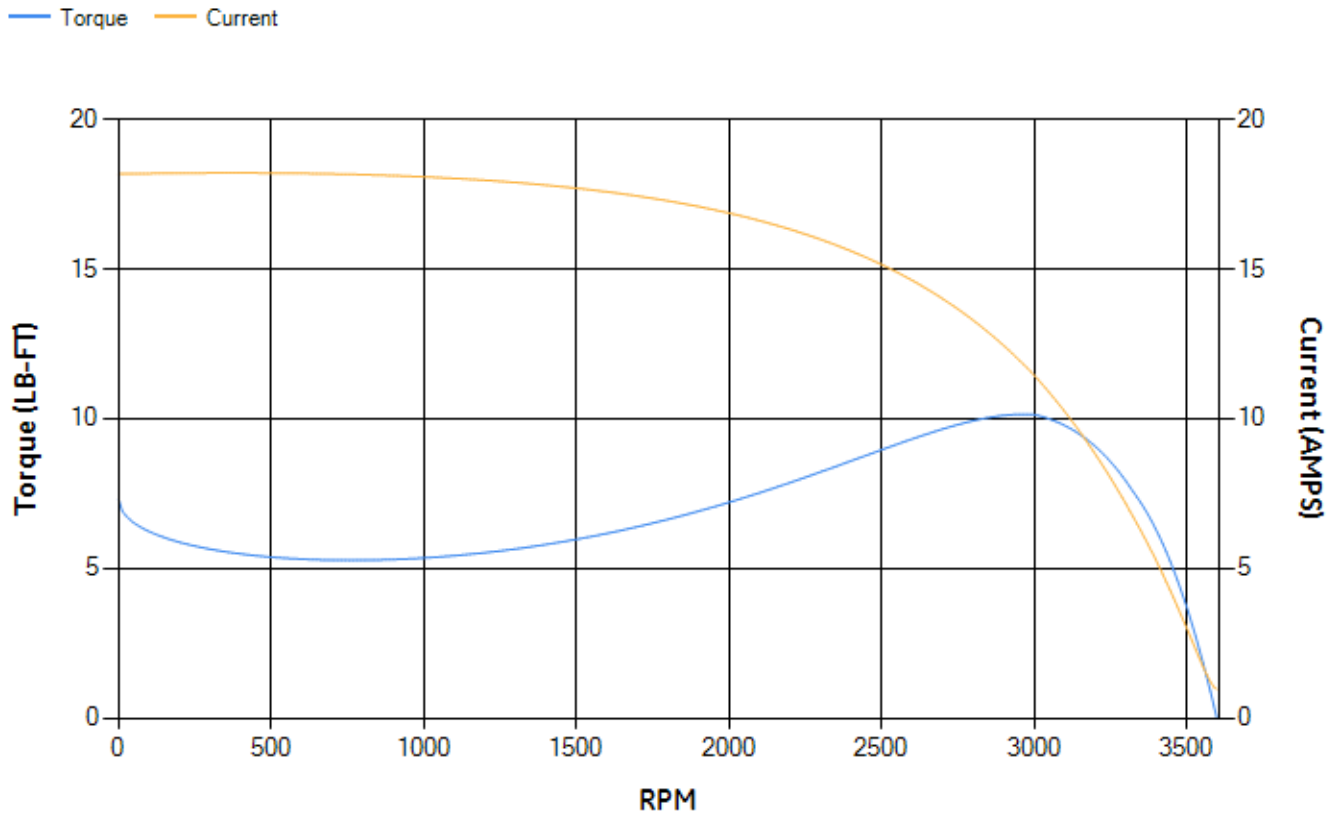

Marks:

NOTE 1: CONDUIT BOX MAY BE ASSEMBLED WITH ENTRANCE UP, DOWN OR TO EITHER SIDE.
 NOTE 2: F1 ASSEMBLY AS SHOWN. F2 ASSEMBLY CONDUIT BOX ON OPPOSITE SIDE FROM SHOWN LOCATION.

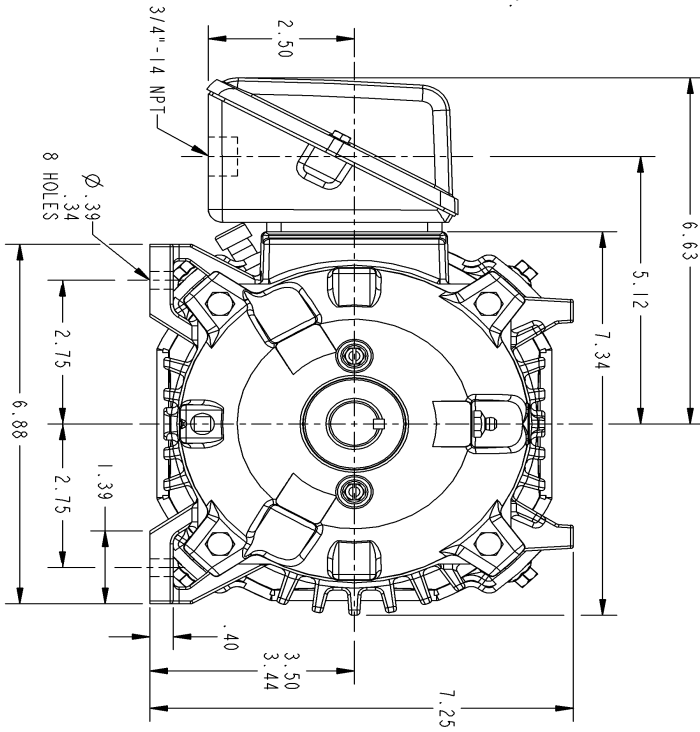
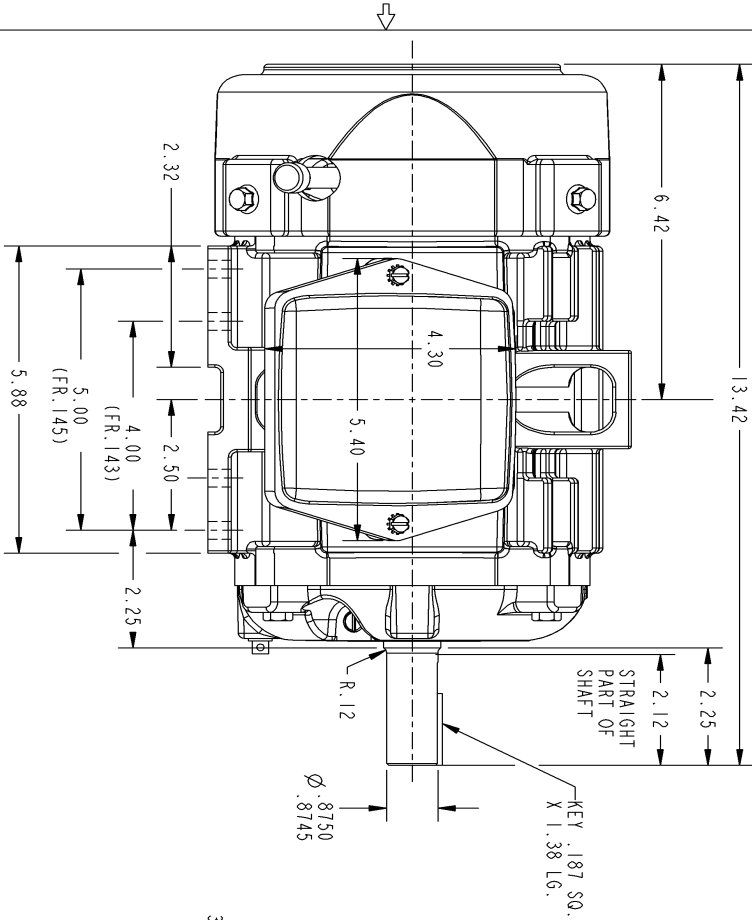

SIZE DRAWING NO.
B 4002B5814PAP5201

SM REV
1 1

REV.	DESCRIPTION	DATE	APPROVED
1.	REMOVED - ULTRA - FROM DESCRIPTION	05/21/03	DCMOHAN

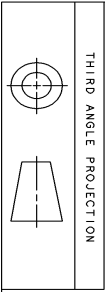

SIGNATURES	DATE	GE Logo	GENERAL ELECTRIC COMPANY
DRWN: GART WARRINE	OCT 24/01	Systems	Fort Wayne, Indiana
CHECKED: GART WARRINE	MAY 22/02	INDUCTION MOTOR OUTLINE STANDARD CONSTRUCTION FME: FR1A0T TEFC	
ISSUED: GART WARRINE	JUN 05/02		
APPLIED PRACTICES			

SIZE DRAWING
B 4002B5814PAP5201 REV. **1**

DISTRIBUTION: PMP-18K15

SCALE: 0.500 REF. NO.: 4002B5814PAP5201 SHEET 1 OF 1

Marks:

Connection Diagram
GEM2034E-FIG3

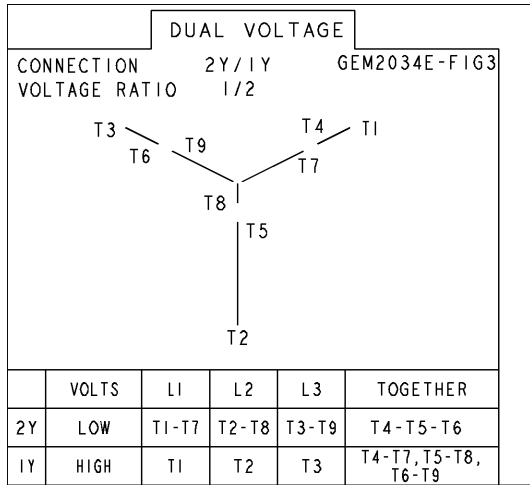

End shield Assembly		
Part Description	DE Side Part#	ODE Side Part#
End Shield	4004D5280PB1	4004D5280SG1
Bearing	235A2600AA01	235A2600AA01
Slinger/Inproseal	149C4399G15	149C4399G15

Fan & Fan Cover Assembly	
Part Description	Part#
Fan	4001A5914AM-G01
Fan Cover	4003C5785PA1

Conduit & Accessories Box Assembly	
Part Description	Part#
Conduit Box	4002B5718PA-G01

Mechanical Accessories	
Part Description	Part#
Brake	
Tachometer	