

Product Information Packet

November 8, 2016

Data shown is for the current revision model #. Ensure your nameplate model # matches.

Model Number:	5KS145XAA220D2
Catalog Number:	M361
Instruction Manual:	GEI-56128
Connection Diagram:	GEM2034E-FIG1
Outline Drawing:	4002B5814PAP5311

Accessory Connection Diagrams			
Bearing Thermocouple:	None	Heater:	None
RTD:	None	Thermistor:	None
Thermostat:	None	Winding Thermocouple:	None
Bearing RTD:	None		

Table of Contents

Specification	01
Performance Characteristics	02
Outline Drawing	03
Connection Drawing(s)	04
Spare parts	05



Marks:

MODEL NUMBER:	5KS145XAA220D2	Estimated Weight:	50 Lbs
Outline Drawing:	4002B5814PAP5311	Time Rating:	CONT
Connection Diagram:	GEM2034E-FIG1	Enclosure:	TEFC
Instruction Book:	GEI-56128	Encl Construction:	841
Design Code:	14BD1093A	Ambient Max(°C):	40
Type:	KS	Alt Ambient Max(°C):	--
Frame:	145T	Insulation Class:	H
Phases:	3	NEMA Design:	B
Poles:	4	Nominal Efficiency:	86.5 %
Output Power:	2HP 1.5KW	Guaranteed Efficiency:	85.5
RPM:	1735	3/4 Load Efficiency:	87.0
Voltage:	460	KVA Code:	L
Hertz:	60	Max KVAR:	1.0
Amps - FL:	2.7	Power Factor:	79.0
Service Factor:	1.15	Bearing - DE:	6205ZC3
Alt Service Factor:	--	Bearing - ODE:	6205ZC3

Enclosure is Totally Enclosed Fan-Cooled

Stamped Nameplate Notes:

IEEE-STD-841-2009
 DE BRG 25BC02JP30 ODE BRG 25BC02JP30
 STAMP NP249A5564P051 AS BELOW:
 MODEL:5KS145XAA220D2 S/N: XXX
 CSA CERTIFIED CSA09.2216219 FOR EX NA IIC 200 C GC
 CL1 ZONE2 AEXNAIIC 200C FOR CL1DIV2 GRP ABCD 200C
 IN -25C <= AMB <= 40C, 1.0 SF ON SINE-WAVE PWR
 SURF TEMP 200 C AT 1.15 SF ON SINE-WAVE PWR
 OR 200 C VT OR 200 C CT OR 200 C CHP PWM CONTROL
 ALTERNATE RATING FOR PWM CONTROL 1.0 SF 40 C AMB
 VT 0-60 HZ, CT 3-60 HZ, CHP 60-90 HZ.

Additional Information:

4P - T EXTN
 STANDARD FLOOR MOUNT
 C/BOX 30 CU IN-0.75 NPT
 F1 CONDUIT BOX MOUNTING
 PAINTED FRAME ID & SHAFT,
 FAN COVER INSIDE & ODE E/S OUTSIDE
 ROUTINE AND 5 POINT VIBRATION TESTS INCL IN C/BOX
 INPRO SEAL BOTH ENDS
 GROUND SCREW ON FRAME
 SHAFT RUNOUT LIMIT .001" TIR
 COPPER WASHER UNDER HEADS OF BEARING CAP BOLTS
 APPLY TITE-SEAL (A50CD427A) ON BEARING CAP SCREWS, RABBETS,
 AND PLUG THREADS
 OIL RESISTANT SLEEVING ON LEADS

Performance Characteristics

1st Winding 1st Connection

Design: 14BD1093A

Marks:

LOAD %	125.0	115.0	100.0	75.0	50.0	25.0	0.0
% EFF	85.07	85.68	86.62	87	85.96	79.68	0.00
% PF	83.32	81.79	80.24	71.2	58.24	37.01	7.23
AMPS	3.3	3.07	2.68	2.27	1.87	1.59	1.37

TORQ(FL)#FT	6.05	TORQ(LR)%FL	394.29	TORQ(BD)%FL	436.54
AMPS(LR)	20.52	PF AT START	0.68		

This motor is capable of two cold or one hot start with a maximum connected load inertia of 105 Lb-Ft Sq (4.42 Kg-meter Sq)at 100% voltage, where the load torque varies with the square of the speed. Acceleration time with maximum inertia and the above load type is 28 seconds. Safe stall time at 100% voltage is 59 seconds cold, 44 seconds hot. Rotor inertia is 0.12 Lb-Ft Sq (0.01 Kg-meter Sq).

Open Circuit A-C:	0.129	Short Circuit D-C:	0.005
Short Circuit A-C:	0.005	X/R Ratio:	1.753
Stator Slots:	36	Rotor Slots:	48

Speed Torque Current Curve (First Connection, First Speed)

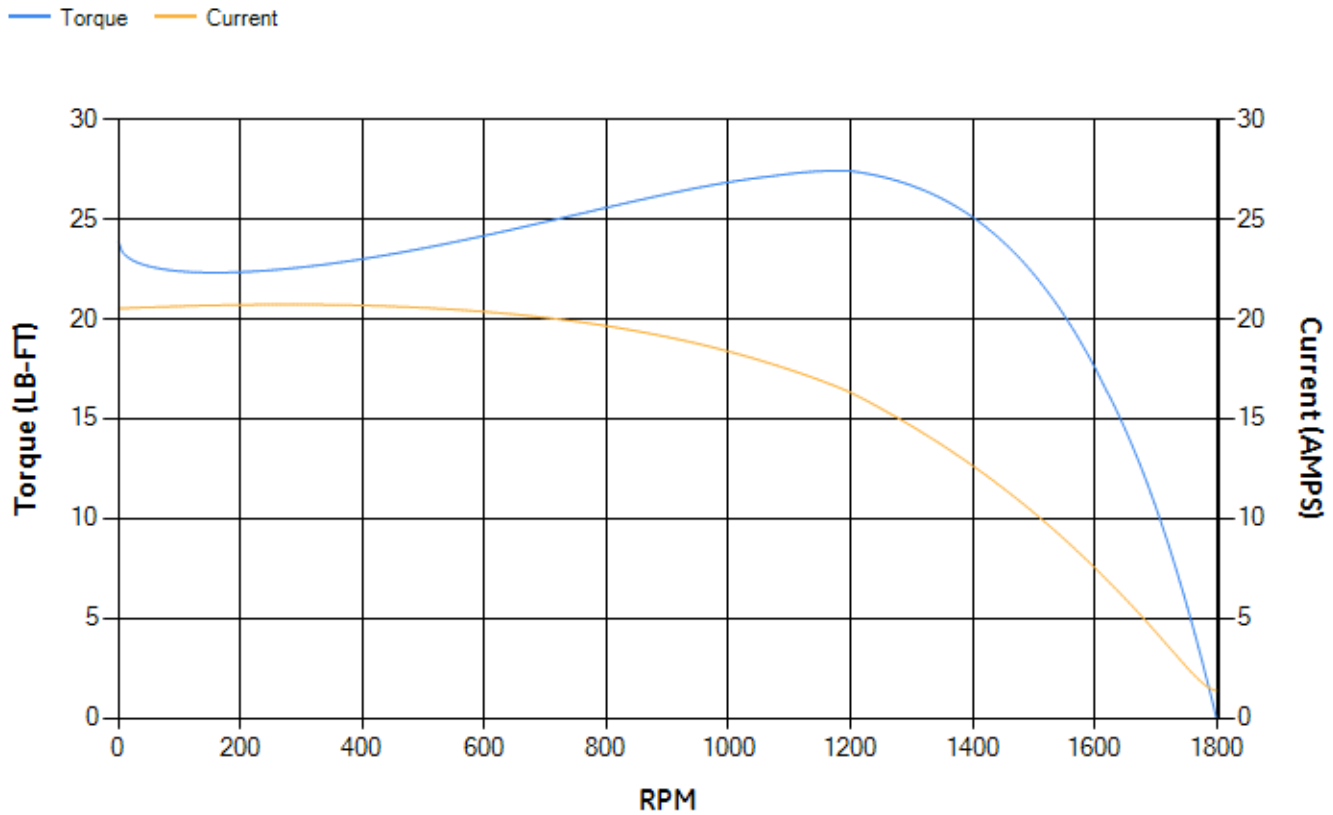

Marks:

NOTE 1: CONDUIT BOX MAY BE ASSEMBLED WITH ENTRANCE UP, DOWN OR TO EITHER SIDE.
 NOTE 2: FI ASSEMBLY AS SHOWN.
 NOTE 3: SHAFT RUNOUT WILL NOT EXCEED .001 T. I. R.
 NOTE 4: ALL DIMENSIONS ARE IN INCHES, BRACKETED DIMENSIONS ARE IN METRIC (MILLIMETERS).

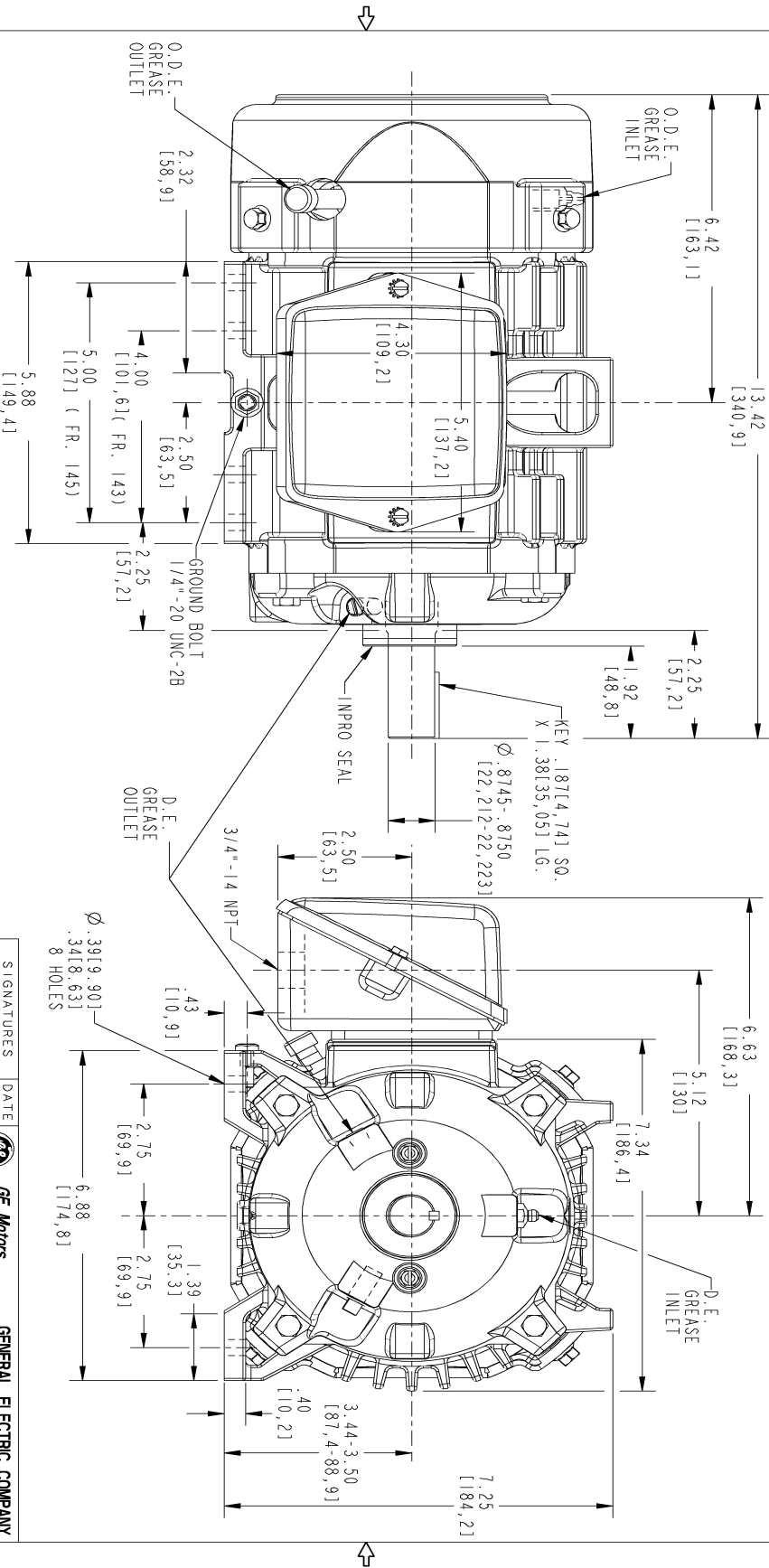

SIZE DRAWING NO. B

4002B5814PAP5311

REV SHEET 1 1

REVISIONS

REV.	DESCRIPTION	DATE	APPROVED
1	ISAAC # 15-0944 HARIKIRAN	09/24/15	SAGAR

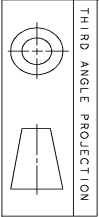

THIRD ANGLE PROJECTION

SIGNATURES	DATE	GE Motors	GENERAL ELECTRIC COMPANY
MODEL: TEJASNI	06/03/15		
DETAIL: TEJASNI	06/03/15		
CHECKED: KARTHIK	06/03/15		
ENG: VENKAT	06/03/15		
QUALITY: TEJASNI	06/03/15		
ISSUED: B			

INDUCTION MOTOR OUTLINE
 STANDARD CONSTRUCTION FOR IEEE-841 SPEC
 FME: FR140T TFC
4002B5814PAP5311
 SCALE: 0.500 REF. No.: 4002B5814PAP5301

SHEET 1 OF 1

Marks:

Connection Diagram
GEM2034E-FIG1



End shield Assembly		
Part Description	DE Side Part#	ODE Side Part#
End Shield	4004D5280PB1	4004D5280SG1
Bearing	235A2600AA01	235A2600AA01
Slinger/Inproseal	4002B5914AF1	4002B5914AG1

Fan & Fan Cover Assembly	
Part Description	Part#
Fan	4001A5914AM-G01
Fan Cover	4003C5785PA1

Conduit & Accessories Box Assembly	
Part Description	Part#
Conduit Box	4002B5718PA-G01

Mechanical Accessories	
Part Description	Part#
Brake	
Tachometer	

