

4

3

2

1

B

B

A

A

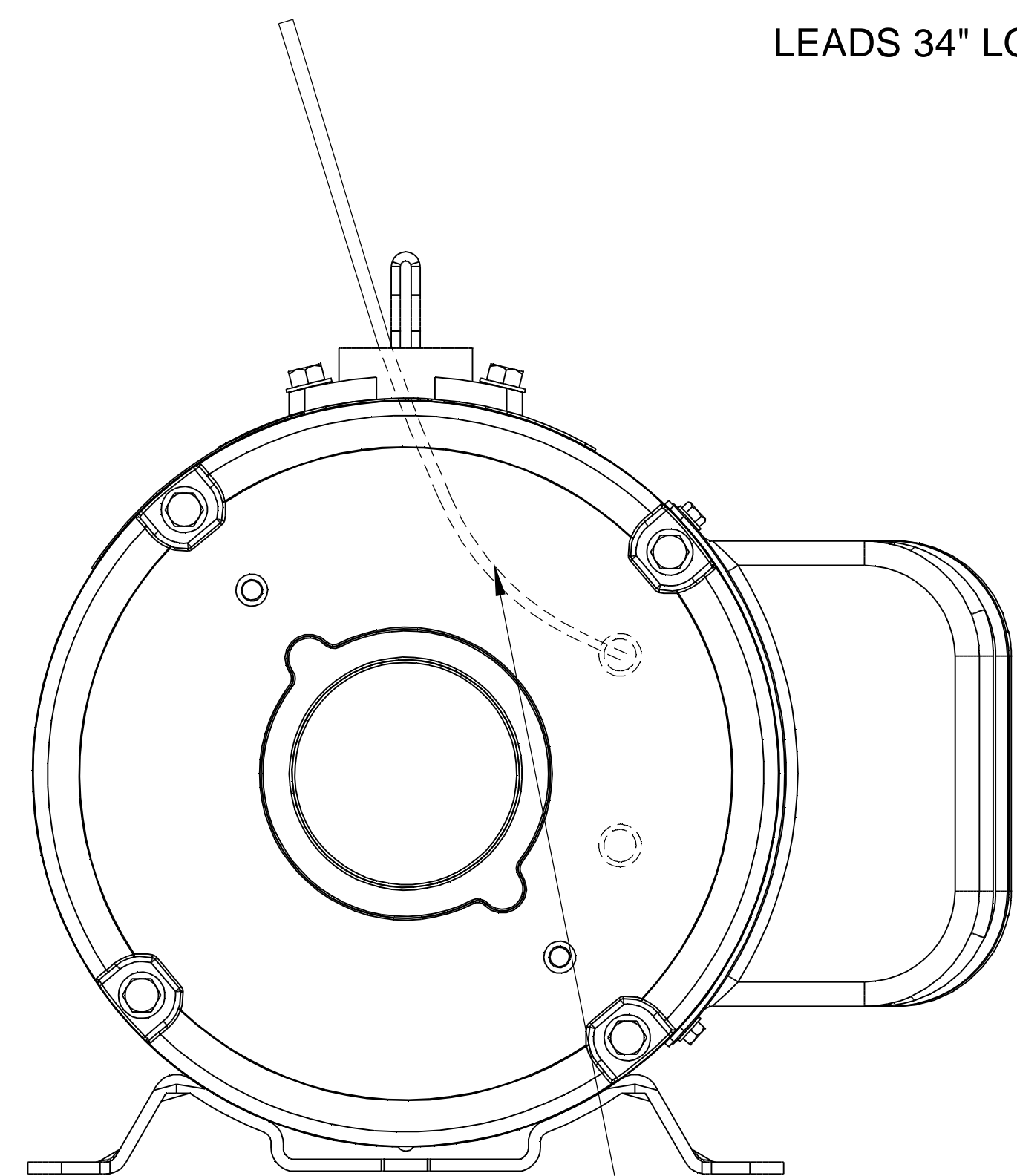
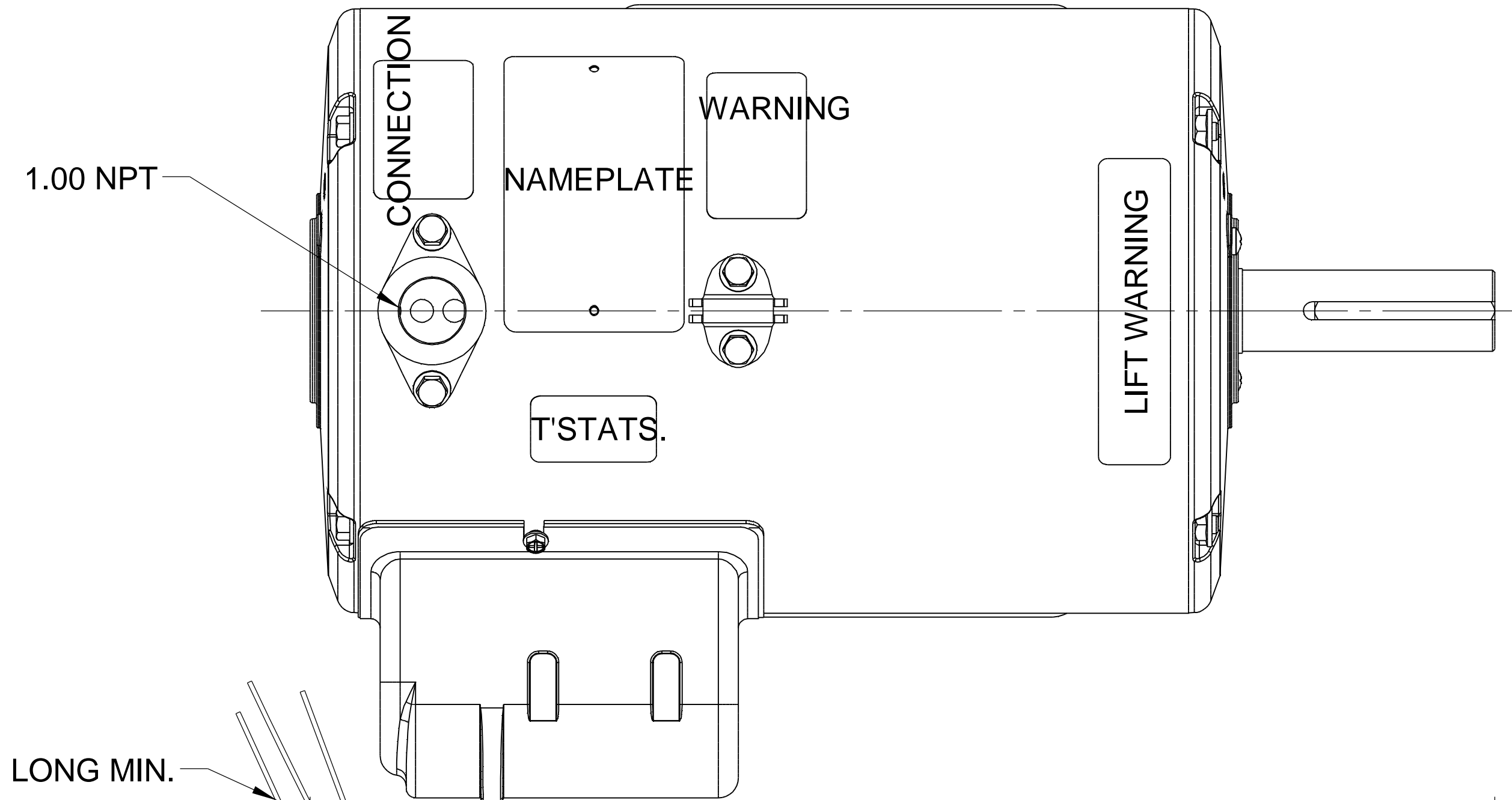

GROUND LEAD 34" LONG MIN. ATTACHED TO PROTECTOR BOSS WITH #10-32 GROUND SCREW

LEADS 34" LONG MIN.

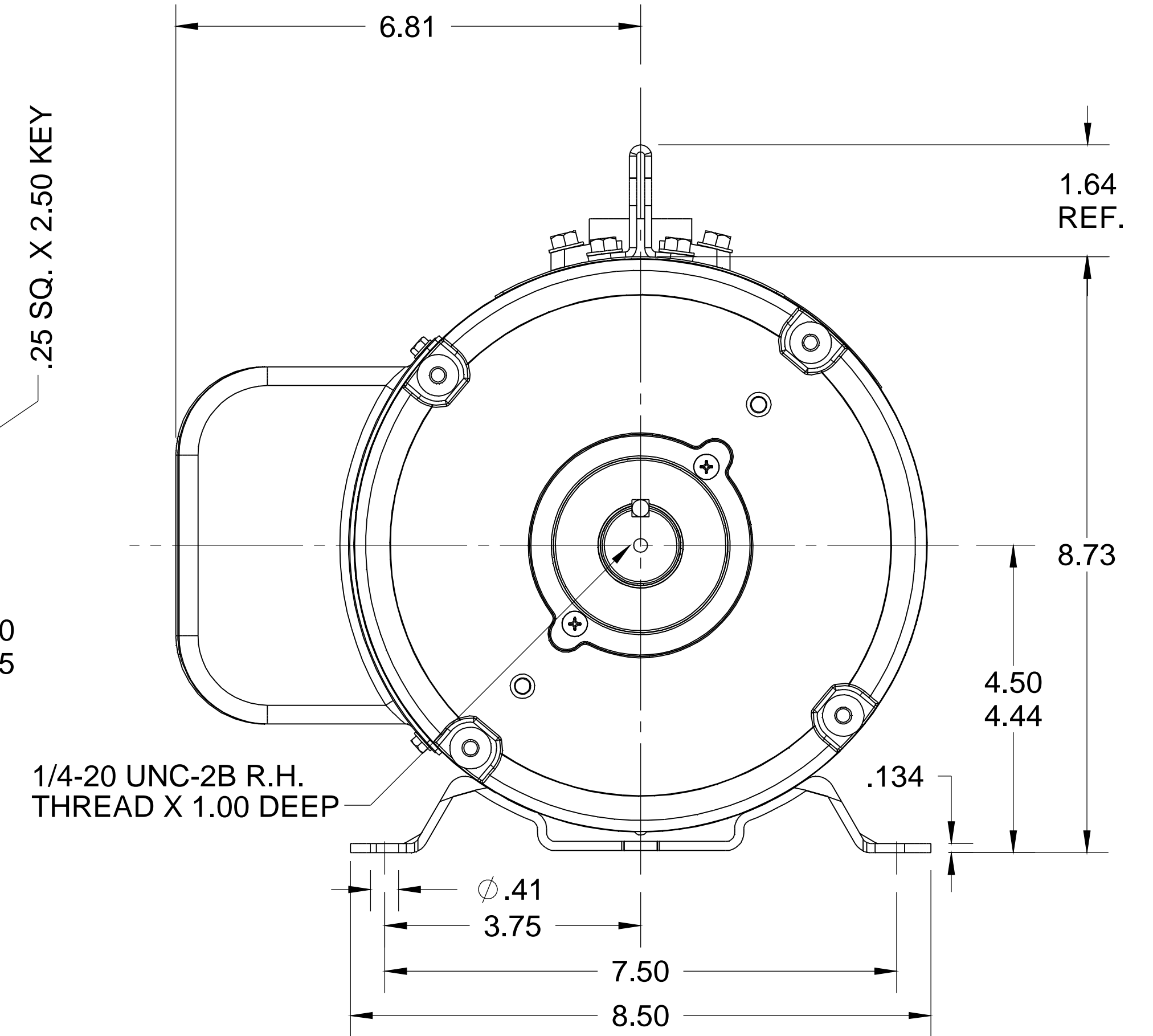
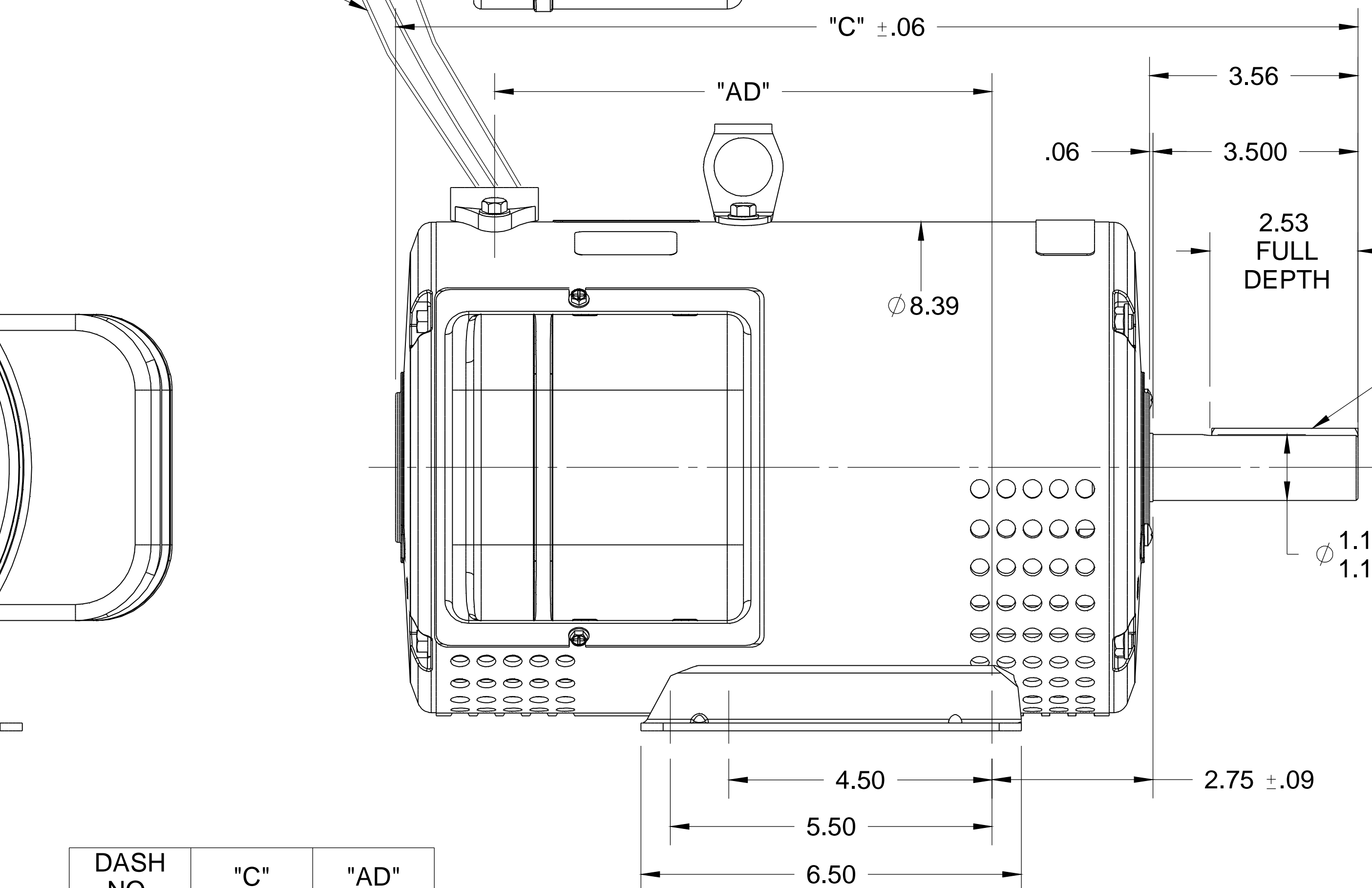

DASH NO.	"C"	"AD"
1050	15.44	7.50
1100	15.94	8.00
1150	16.44	8.50
1200	16.94	9.00
1250	17.44	9.50
1300	17.94	10.00
1350	18.44	10.50
1400	18.94	11.00

DRAWING REVISION G	REVISION BY M.MCCALEB	DATE 04-27-2015
ECO ECO-0076543	APPROVED BY G.SCHALLOCK	DATE 04-27-2015
ECO DESCRIPTION 1.00 NPT WAS 3/4-14 NPT		
<small>COPYRIGHT REGAL BELOIT AMERICA, INC. ALL RIGHTS RESERVED. PROPRIETARY AND CONFIDENTIAL INFORMATION - THIS DOCUMENT IS THE PROPERTY OF REGAL BELOIT AMERICA, INC. ("OWNER") AND CONTAINS OWNER'S PROPRIETARY INFORMATION. ANY PERSON, CORPORATION OR OTHER FIRM RECEIVING IT IS DEEMED, BY RECEIVING IT, TO AGREE THAT IT, AND/OR ANY PART OF IT, SHALL NOT BE DISCLOSED TO ANY PERSON, CORPORATION OR OTHER ENTITY, DUPLICATED, AND/OR USED, EXCEPT AS EXPRESSLY APPROVED IN WRITING IN ADVANCE BY OWNER. THIS DOCUMENT SHALL BE RETURNED TO OWNER UPON REQUEST. IT MAY BE SUBJECT TO CERTAIN RESTRICTIONS UNDER APPLICABLE EXPORT CONTROL LAWS AND REGULATIONS.</small>		

TOLERANCES UNLESS OTHERWISE SPECIFIED:
 DEC. INCH ±.1 [±2.5] ANGLE ±0.5°
 .X ±0.1 [±2.5]
 .XX ±0.03 [±0.76]
 .XXX ±0.005 [±0.127]
 .XXXX ±0.0005 [±0.0127]
 REMOVE BURRS & BREAK SHARP EDGES: .003/.015 [.076/.381] X 45°
 CORNER FILLETS: R.02 [.51]
 MACHINED SURFACES: 125 INCH 3.2 mm
 mm SHOWN IN [BRACKETS]

DRAWN BY
LST
 DATE
5/5/09
 APPROVED BY
 DATE
 REFERENCE
 THIRD ANGLE PROJECTION

REGAL™ Regal Beloit America, Inc.

DESCRIPTION
OUTLINE
DRIP PROOF - RIGID

MATERIAL PROCESS/FINISH

SIZE **B** DRAWING NUMBER **035732** SHEET **1 OF 1**

ORACLE REV 003

4

3

2

1