

Product Information Packet

November 8, 2016

Data shown is for the current revision model #. Ensure your nameplate model # matches.

Model Number:	5KS444SAA308D6
Catalog Number:	M9133
Instruction Manual:	GEI-56128
Connection Diagram:	GEM2034E-FIG7
Outline Drawing:	239C6600AA

Accessory Connection Diagrams			
Bearing Thermocouple:	None	Heater:	None
RTD:	None	Thermistor:	None
Thermostat:	None	Winding Thermocouple:	None
Bearing RTD:	None		

Table of Contents

Specification	01
Performance Characteristics	02
Outline Drawing	03
Connection Drawing(s)	04
Spare parts	05



Marks:

MODEL NUMBER:	5KS444SAA308D6	Estimated Weight:	1880 Lbs
Outline Drawing:	239C6600AA	Time Rating:	CONT
Connection Diagram:	GEM2034E-FIG7	Enclosure:	TEFC
Instruction Book:	GEI-56128	Encl Construction:	X\$D
Design Code:	44BD3081A	Ambient Max(°C):	40
Type:	KS	Alt Ambient Max(°C):	65
Frame:	444T	Insulation Class:	H
Phases:	3	NEMA Design:	B
Poles:	6	Nominal Efficiency:	95.0 %
Output Power:	100HP 74KW	Guaranteed Efficiency:	94.5
RPM:	1190	3/4 Load Efficiency:	95.1
Voltage:	460	KVA Code:	G
Hertz:	60	Max KVAR:	35.7
Amps - FL:	122.0	Power Factor:	81.0
Service Factor:	1.25	Bearing - DE:	6318ZC3
Alt Service Factor:	1.00	Bearing - ODE:	6318ZC3

Enclosure is Totally Enclosed Fan-Cooled

Stamped Nameplate Notes:

SF AMPS 149.3
 STAMP NP249A5564P051 AS BELOW:
 MODEL:5KS444SAA308D6 S/N: XXX
 CSA CERTIFIED CSA09.2216219 FOR EX NA IIC 200 C GC
 CL 1 ZONE2 AEX NA IIC 200C;CL 1 DIV2 GRP ABCD 200C
 IN -40C <= AMB <= 40C, 1.0 SF ON SINE-WAVE PWR
 SURF TEMP 230C AT 1.25SF ON SINE-WAVE PWR
 OR 200C VT OR 230C CT OR 200C CHP PWM CONTROL
 ALTERNATE RATING FOR PWM CONTROL 1.0SF 40C AMB
 VT 0 - 60 HZ, CT 6-60 HZ, CHP 60-90 HZ.

Additional Information:

6P - T EXTN
 700 CU IN - 3.00" NPT
 OIL RESISTANT SLEEVING ON LEADS
 F1 MOUNTING

Performance Characteristics

1st Winding 1st Connection

Design: 44BD3081A

Marks:

LOAD %	125.0	115.0	100.0	75.0	50.0	25.0	0.0
% EFF	94.38	94.61	95.09	95.09	94.65	91.92	0.00
% PF	83.04	82.54	81.21	76.66	66.5	44.2	3.53
AMPS	149.27	137.83	121.2	96.29	74.35	57.58	49.86

TORQ(FL)#FT	440.81	TORQ(LR)%FL	180.49	TORQ(BD)%FL	245.77
AMPS(LR)	712.54	PF AT START	0.34		

This motor is capable of two cold or one hot start with a maximum connected load inertia of 5267 Lb-Ft Sq (221.74 Kg-meter Sq)at 100% voltage, where the load torque varies with the square of the speed. Acceleration time with maximum inertia and the above load type is 42 seconds. Safe stall time at 100% voltage is 83 seconds cold, 51 seconds hot. Rotor inertia is 78.74 Lb-Ft Sq (3.31 Kg-meter Sq).

Open Circuit A-C:	0.821	Short Circuit D-C:	0.025
Short Circuit A-C:	0.052	X/R Ratio:	9.32
Stator Slots:	72	Rotor Slots:	58

Speed Torque Current Curve (First Connection, First Speed)

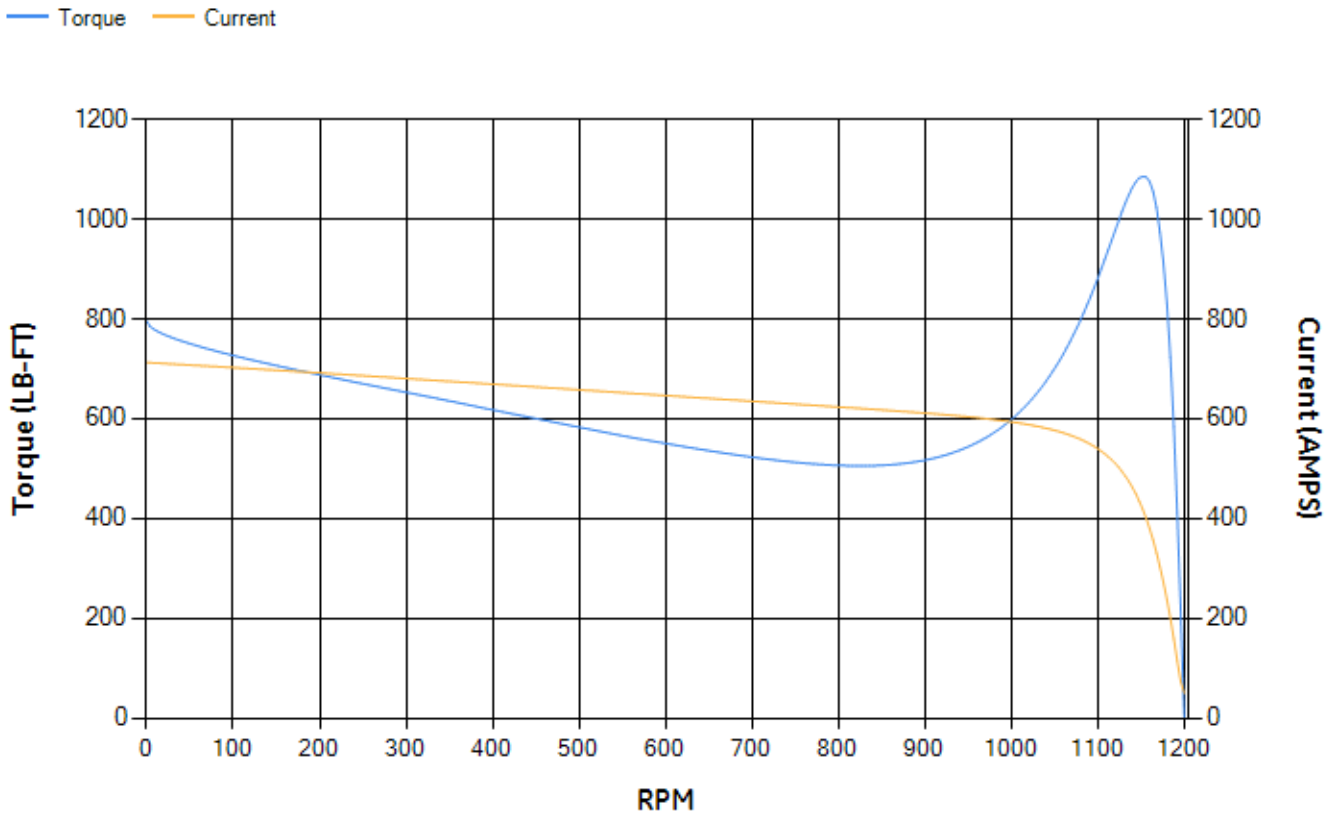

Marks:

REV.	DESCRIPTION	DATE	APPROVED
1	ECH 01-0311	02/05/01	
2	ADDED FAN COVER FIG. CPA	04/30/01	
3	SAC 02-0273 MARGAJ	02/04/02	
4	SAC 03-2024	08/06/03	
5	SAC 13-0248	03/22/13	

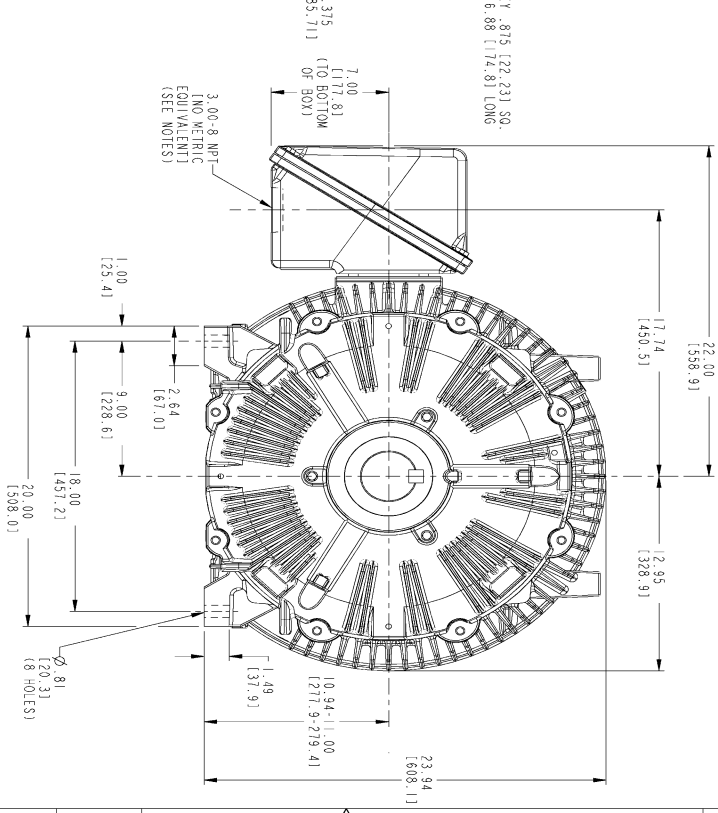
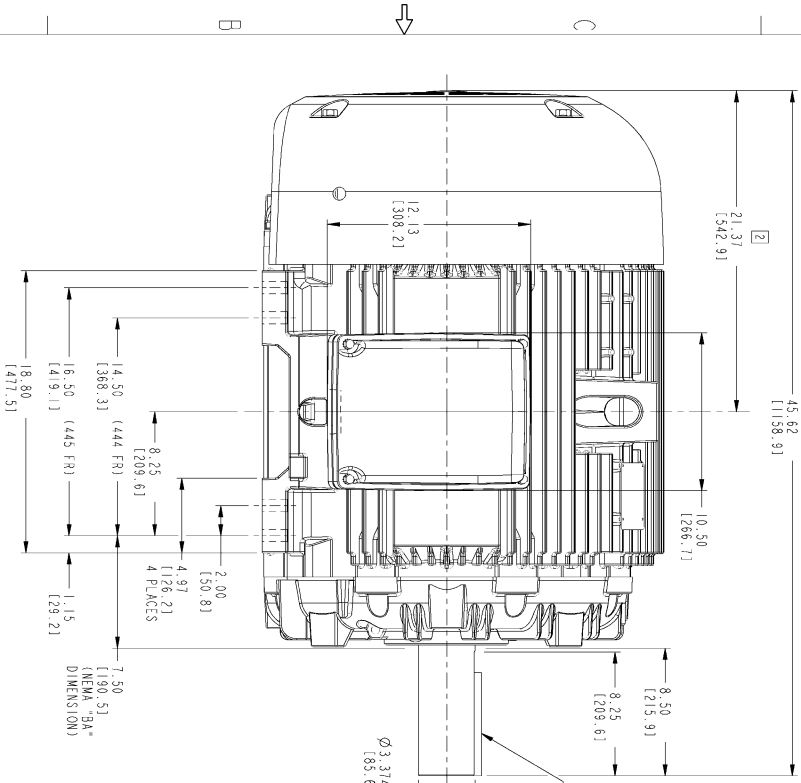

- NOTES:
- CONDUIT BOX MAY BE PLACED WITH THE ENTRANCE DOWN, UP OR ON EITHER SIDE.
 - F-1 ASSEMBLY AS SHOWN.
 - F-2 ASSEMBLY HAS CONDUIT BOX ON OPPOSITE SIDE.
 - BRACKETED DIMENSIONS ARE METRIC (MILLIMETERS).

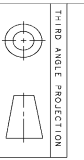

THIRD ANGLE PROJECTION

SIGNATURES	DATE	GE Industrial Systems	GENERAL ELECTRIC COMPANY
J.M. JUREN	04/17/00		Fort Wayne, Indiana
W. ELSWORTH	04/17/00		
D. STARK	04/17/00		
W. ELSWORTH	04/17/00		

APPLIED PRACTICES

SIZE DRAWING

700 CU. IN. CONDUIT BOX

239C6600AA

SCALE: 0.200 REF. NO. 5

DISTRIBUTION: MMP

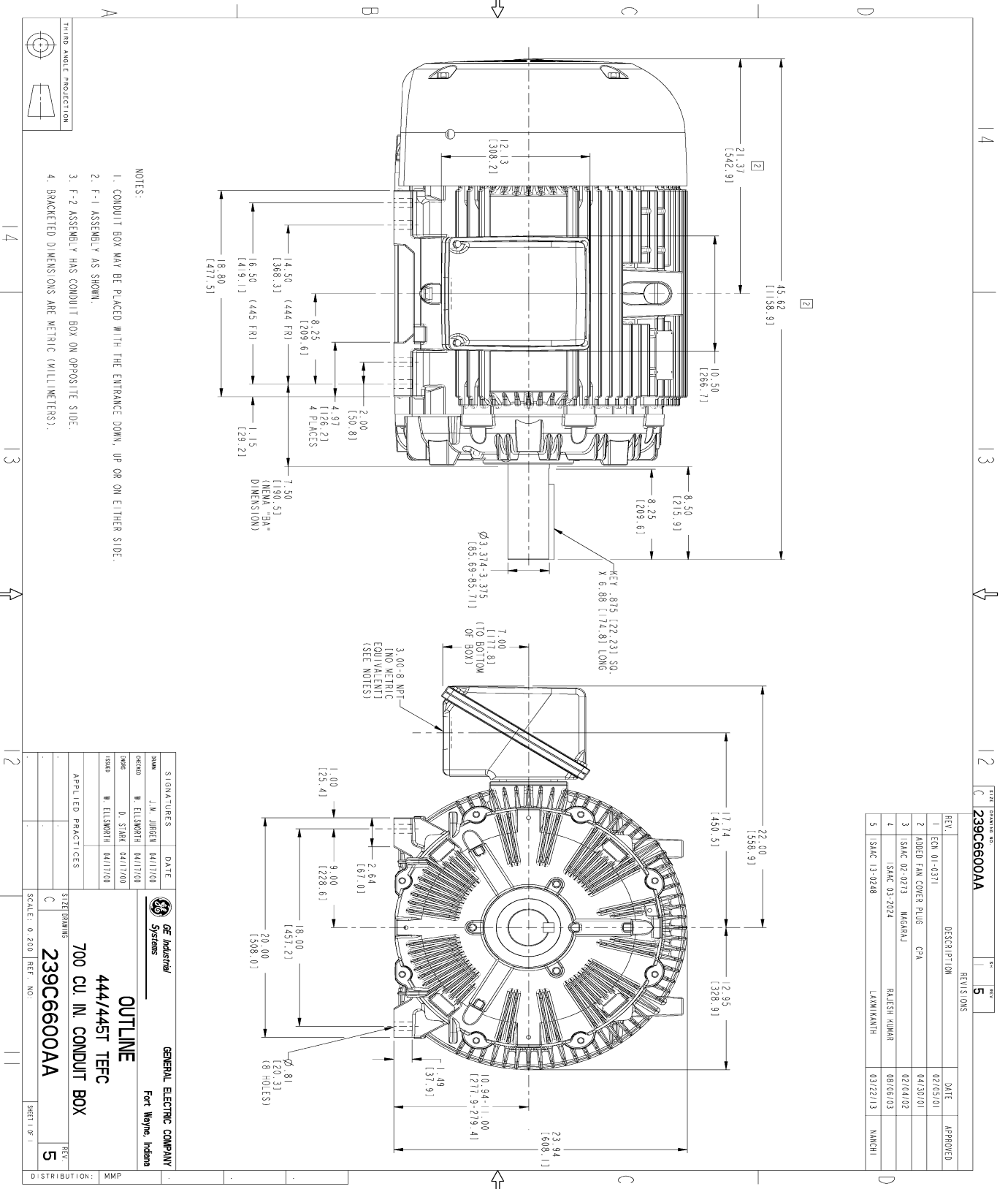

Marks:

Connection Diagram
GEM2034E-FIG7



End shield Assembly		
Part Description	DE Side Part#	ODE Side Part#
End Shield	115E4355AA1	115E4355LM1
Bearing	235A2514AG01	235A2514AG01
Slinger/Inproseal	149C4399G07	149C4399G07

Fan & Fan Cover Assembly	
Part Description	Part#
Fan	159C7100G03
Fan Cover	128D6841AA1

Conduit & Accessories Box Assembly	
Part Description	Part#
Conduit Box	118D4408AD2

Mechanical Accessories	
Part Description	Part#
Brake	
Tachometer	