

Product Information Packet

November 8, 2016

Data shown is for the current revision model #. Ensure your nameplate model # matches.

Model Number:	5KS286XAA118D3
Catalog Number:	M9446
Instruction Manual:	GEI-56128
Connection Diagram:	GEM2034E-FIG7
Outline Drawing:	4002B5828PAP5313

Accessory Connection Diagrams			
Bearing Thermocouple:	None	Heater:	None
RTD:	None	Thermistor:	None
Thermostat:	None	Winding Thermocouple:	None
Bearing RTD:	None		

Table of Contents

Specification	01
Performance Characteristics	02
Outline Drawing	03
Connection Drawing(s)	04
Spare parts	05



Marks:

MODEL NUMBER:	5KS286XAA118D3	Estimated Weight:	510 Lbs
Outline Drawing:	4002B5828PAP5313	Time Rating:	CONT
Connection Diagram:	GEM2034E-FIG7	Enclosure:	TEFC
Instruction Book:	GEI-56128	Encl Construction:	841
Design Code:	28BD0153A	Ambient Max(°C):	40
Type:	KS	Alt Ambient Max(°C):	--
Frame:	286TS	Insulation Class:	H
Phases:	3	NEMA Design:	B
Poles:	2	Nominal Efficiency:	92.4 %
Output Power:	30HP 22.2KW	Guaranteed Efficiency:	91.7
RPM:	3545	3/4 Load Efficiency:	93.4
Voltage:	460	KVA Code:	G
Hertz:	60	Max KVAR:	4.2
Amps - FL:	32.7	Power Factor:	93.0
Service Factor:	1.15	Bearing - DE:	6310ZC3
Alt Service Factor:	--	Bearing - ODE:	6310ZC3

Enclosure is Totally Enclosed Fan-Cooled

Stamped Nameplate Notes:

IEEE-STD-841-2009
 DE BRG 50BC03JP30 ODE BRG 50BC03JP30
 STAMP NP249A5564P051 AS BELOW:
 MODEL:5KS286XAA118D3 S/N: XXX
 CSA CERTIFIED CSA09.2216219 FOR EX NA IIC 200 C GC
 CL1 ZONE2 AEX NA IIC 200C; CL1 DIV2 GRP ABCD 200C
 IN -25C <= AMB <= 40C, 1.0 SF ON SINE-WAVE PWR
 SURF TEMP 260C AT 1.15 SF ON SINE-WAVE PWR
 OR 200 C VT OR 215 C CT OR 215 C CHP PWM CONTROL
 ALTERNATE RATING FOR PWM CONTROL 1.0 SF 40 C AMB
 VT 0-60 HZ, CT 15-60 HZ, CHP 60-90 HZ.

Additional Information:

2P - TS EXTN
 STANDARD FLOOR MOUNT
 C/BOX 137 CU IN-1.50 NPT
 F1 CONDUIT BOX MOUNTING
 PAINTED FRAME ID & SHAFT,
 FAN COVER INSIDE & ODE E/S OUTSIDE
 ROUTINE AND 5 POINT VIBRATION TESTS INCL IN C/BOX
 INPRO SEAL BOTH ENDS
 GROUND SCREW ON FRAME
 SHAFT RUNOUT LIMIT .001" TIR
 COPPER WASHER UNDER HEADS OF BEARING CAP BOLTS
 APPLY TITE-SEAL (A50CD427A) ON BEARING CAP SCREWS, RABBETS,
 AND PLUG THREADS
 OIL RESISTANT SLEEVING ON LEADS

Performance Characteristics

1st Winding 1st Connection

Design: 28BD0153A

Marks:

LOAD %	125.0	115.0	100.0	75.0	50.0	25.0	0.0
% EFF	91.42	91.93	92.8	93.37	93.43	91.04	0.00
% PF	92.42	92.7	92.9	92.36	89.48	77.1	9.71
AMPS	41.54	37.89	32.57	24.42	16.79	10	5.88

TORQ(FL)#FT	44.4	TORQ(LR)%FL	283.33	TORQ(BD)%FL	272.76
AMPS(LR)	217.27	PF AT START	0.43		

This motor is capable of two cold or one hot start with a maximum connected load inertia of 111 Lb-Ft Sq (4.67 Kg-meter Sq) at 100% voltage, where the load torque varies with the square of the speed. Acceleration time with maximum inertia and the above load type is 18 seconds. Safe stall time at 100% voltage is 38 seconds cold, 21 seconds hot. Rotor inertia is 3.25 Lb-Ft Sq (0.14 Kg-meter Sq).

Open Circuit A-C:	1.041	Short Circuit D-C:	0.013
Short Circuit A-C:	0.025	X/R Ratio:	5.017
Stator Slots:	48	Rotor Slots:	38

Speed Torque Current Curve (First Connection, First Speed)

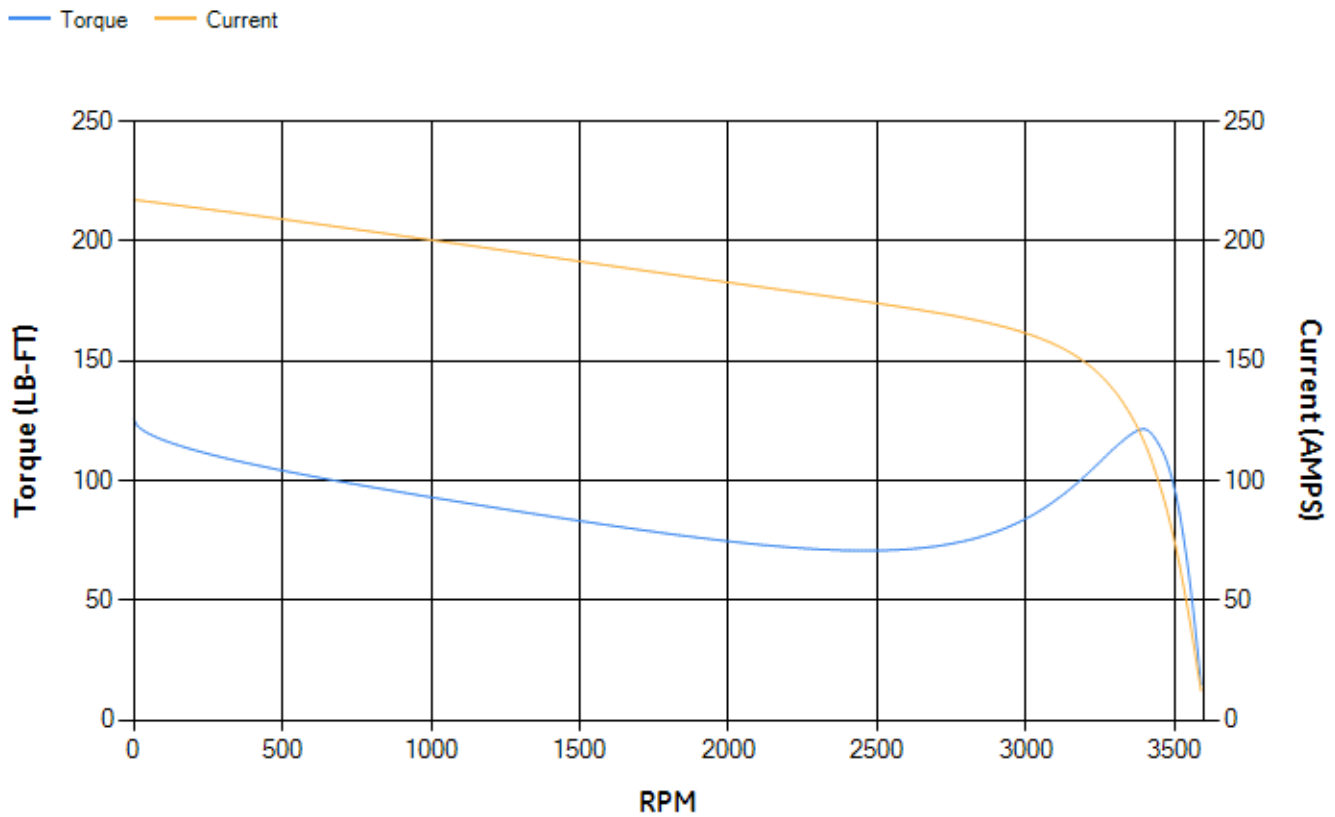

Marks:

NOTE 1: CONDUIT BOX MAY BE ASSEMBLED WITH ENTRANCE UP, DOWN OR TO EITHER SIDE.
 NOTE 2: F1 ASSEMBLY AS SHOWN. F2 ASSEMBLY CONDUIT BOX ON OPPOSITE SIDE FROM SHOWN LOCATION.
 NOTE 3: SHAFT RUNOUT WILL NOT EXCEED .001 T.I.R.
 NOTE 4: ALL DIMENSIONS ARE IN INCHES & BRACKETED DIMENSIONS ARE IN METRIC (MILLIMETERS)

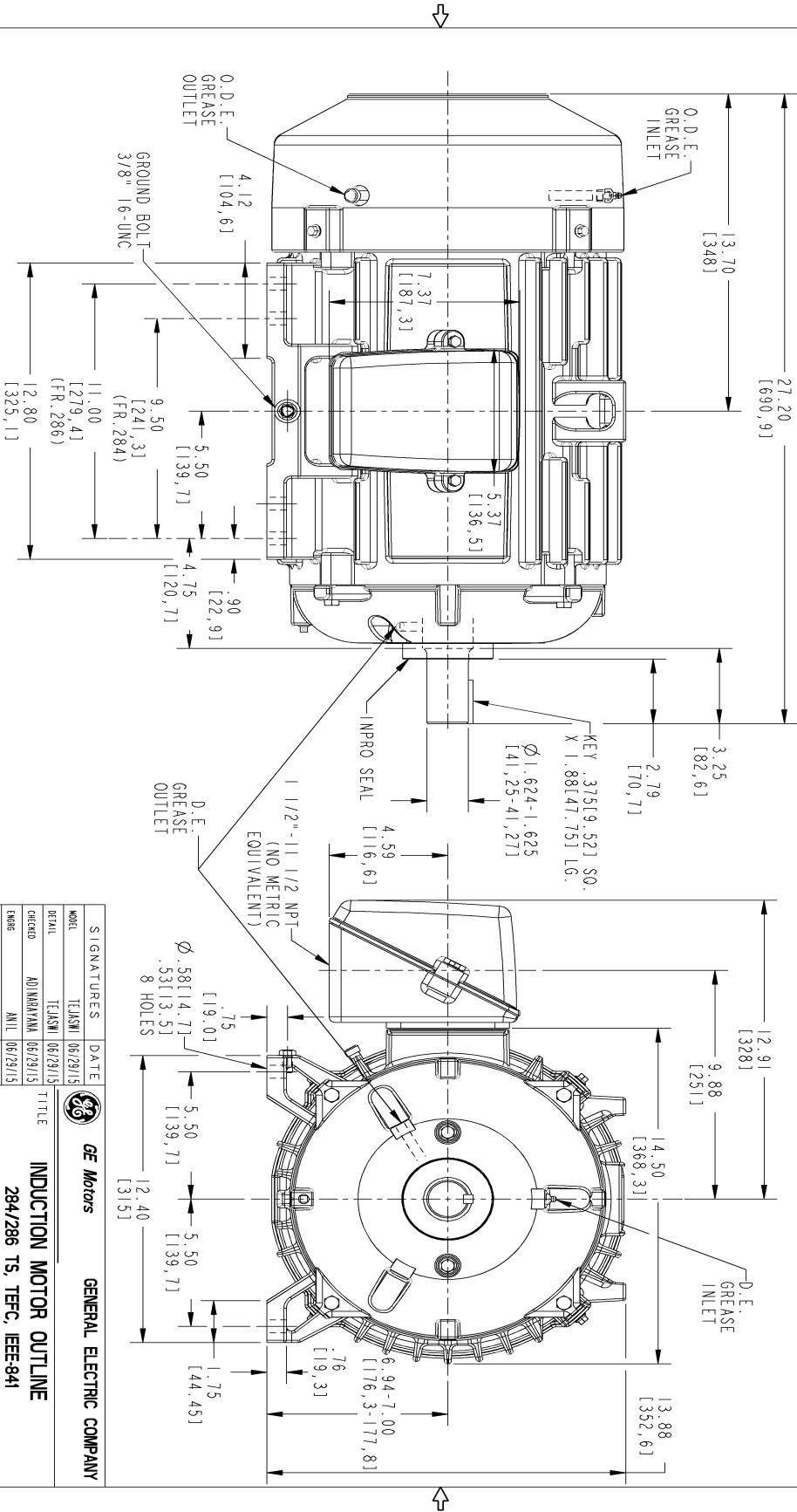

SIZE DRAWING NO.		REV		SHEET	
4002B5828PAP5313		1		1	
REVISIONS					
REV.	DESCRIPTION	DATE	APPROVED		
1	ISAAC # 16-0298	DECPAMANI 04/04/2016	NARAYANA		

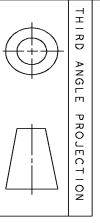

SIGNATURES		DATE		GE Motors		GENERAL ELECTRIC COMPANY	
MODEL	TEJASNI	06/29/15					
DETAIL	TEJASNI	06/29/15					
DESIGNED	ADINIRAYANA	06/29/15					
ENGR	ANIL	06/29/15					
QC							
ISSUED	TEJASNI	06/29/15					
SCALE: 0.250		REF. No.: 4002B5828PAP5302		SHEET 1 of 1			
TITLE		INDUCTION MOTOR OUTLINE					
284/286 TS, TERC, IEEE-841							
CBOX 137 CUIN. - 150 NPT, IMPRO SEAL, GROUND PAD							
SIZE DRAWING		4002B5828PAP5313					
QUALITY		REV 1					

Marks:

Connection Diagram
GEM2034E-FIG7



End shield Assembly		
Part Description	DE Side Part#	ODE Side Part#
End Shield	4004D5284PB1	4004D5284SE1
Bearing	235A2608AA01	235A2608AA01
Slinger/Inproseal	4002B5914AF6	4002B5914AG5

Fan & Fan Cover Assembly	
Part Description	Part#
Fan	159C6704G02
Fan Cover	4003C5789PA1

Conduit & Accessories Box Assembly	
Part Description	Part#
Conduit Box	4002B5728PA-G01

Mechanical Accessories	
Part Description	Part#
Brake	
Tachometer	