

# Product Information Packet

November 8, 2016

Data shown is for the current revision model #. Ensure your nameplate model # matches.

<b>Model Number:</b>	<b>5KS182XAA2004B</b>
<b>Catalog Number:</b>	<b>M9409</b>
<b>Instruction Manual:</b>	GEI-56128
<b>Connection Diagram:</b>	GEM2034E-FIG1
<b>Outline Drawing:</b>	4002B5818PDP5310

Accessory Connection Diagrams			
<b>Bearing Thermocouple:</b>	None	<b>Heater:</b>	None
<b>RTD:</b>	None	<b>Thermistor:</b>	None
<b>Thermostat:</b>	None	<b>Winding Thermocouple:</b>	None
<b>Bearing RTD:</b>	None		

## Table of Contents

Specification	01
Performance Characteristics	02
Outline Drawing	03
Connection Drawing(s)	04
Spare parts	05



**Marks:**

<b>MODEL NUMBER:</b>	<b>5KS182XAA2004B</b>	<b>Estimated Weight:</b>	76 Lbs
<b>Outline Drawing:</b>	4002B5818PDP5310	<b>Time Rating:</b>	CONT
<b>Connection Diagram:</b>	GEM2034E-FIG1	<b>Enclosure:</b>	TEFC
<b>Instruction Book:</b>	GEI-56128	<b>Encl Construction:</b>	841
<b>Design Code:</b>	18BD1124AA	<b>Ambient Max(°C):</b>	40
<b>Type:</b>	KS	<b>Alt Ambient Max(°C):</b>	--
<b>Frame:</b>	182TC	<b>Insulation Class:</b>	H
<b>Phases:</b>	3	<b>NEMA Design:</b>	B
<b>Poles:</b>	4	<b>Nominal Efficiency:</b>	89.5 %
<b>Output Power:</b>	3HP 2.2KW	<b>Guaranteed Efficiency:</b>	88.5
<b>RPM:</b>	1765	<b>3/4 Load Efficiency:</b>	89.7
<b>Voltage:</b>	460	<b>KVA Code:</b>	K
<b>Hertz:</b>	60	<b>Max KVAR:</b>	1.3
<b>Amps - FL:</b>	4.0	<b>Power Factor:</b>	78.5
<b>Service Factor:</b>	1.15	<b>Bearing - DE:</b>	6307ZC3
<b>Alt Service Factor:</b>	--	<b>Bearing - ODE:</b>	6206ZC3

**Enclosure is Totally Enclosed Fan-Cooled**

**Stamped Nameplate Notes:**

IEEE-STD-841-2009  
 DE BRG 35BC03JP30 ODE BRG 30BC02JP30  
 STAMP NP249A5564P051 AS BELOW:  
 MODEL:5KS182XAA2004B S/N: XXX  
 CSA CERTIFIED CSA09.2216219 FOR EX NA IIC 200 C GC  
 CL1 ZONE2 AEXNAIIC 200C FOR CL1DIV2 GRP ABCD 200C  
 IN -25C <= AMB <= 40C, 1.0 SF ON SINE-WAVE PWR  
 SURF TEMP 200 C AT 1.15 SF ON SINE-WAVE PWR  
 OR 200 C VT OR 200 C CT OR 200 C CHP PWM CONTROL  
 ALTERNATE RATING FOR PWM CONTROL 1.0 SF 40 C AMB  
 VT 0-60 HZ, CT 3-60 HZ, CHP 60-90 HZ.

**Additional Information:**

4P - T EXTN  
 C/BOX 55 CU IN-1.00 NPT  
 "C" FACE AT DE ENDSHIELD ROUND FRAME  
 VERTICAL MOUNT SHAFT DOWN WITH DRIPCOVER  
 PAINTED FRAME ID & SHAFT,  
 FAN COVER INSIDE & ODE E/S OUTSIDE  
 ROUTINE AND 5 POINT VIBRATION TESTS INCL IN C/BOX  
 INPRO SEAL BOTH ENDS  
 BURNDY SERVIT POST ON FRAME  
 SHAFT RUNOUT LIMIT .001" TIR  
 COPPER WASHER UNDER HEADS OF BEARING CAP BOLTS  
 APPLY TITE-SEAL (A50CD427A) ON BEARING CAP SCREWS, RABBETS,  
 AND PLUG THREADS  
 OIL RESISTANT SLEEVING ON LEADS



**Performance Characteristics**

1st Winding 1st Connection

**Design: 18BD1124AA**

**Marks:**

LOAD %	125.0	115.0	100.0	75.0	50.0	25.0	0.0
% EFF	88.75	89.14	89.75	89.66	88.36	82.36	0.00
% PF	81.28	80.34	79.73	72.32	60.92	39.89	7.35
AMPS	4.87	4.51	3.92	3.25	2.61	2.14	1.82

<b>TORQ(FL)#FT</b>	8.93	<b>TORQ(LR)%FL</b>	247.75	<b>TORQ(BD)%FL</b>	333.63
<b>AMPS(LR)</b>	26.76	<b>PF AT START</b>	0.52		

This motor is capable of two cold or one hot start with a maximum connected load inertia of 160 Lb-Ft Sq (6.74 Kg-meter Sq) at 100% voltage, where the load torque varies with the square of the speed. Acceleration time with maximum inertia and the above load type is 47 seconds. Safe stall time at 100% voltage is 105 seconds cold, 83 seconds hot. Rotor inertia is 0.28 Lb-Ft Sq (0.01 Kg-meter Sq).

<b>Open Circuit A-C:</b>	0.271	<b>Short Circuit D-C:</b>	0.009
<b>Short Circuit A-C:</b>	0.014	<b>X/R Ratio:</b>	3.257
<b>Stator Slots:</b>	36	<b>Rotor Slots:</b>	28

**Speed Torque Current Curve (First Connection, First Speed)**

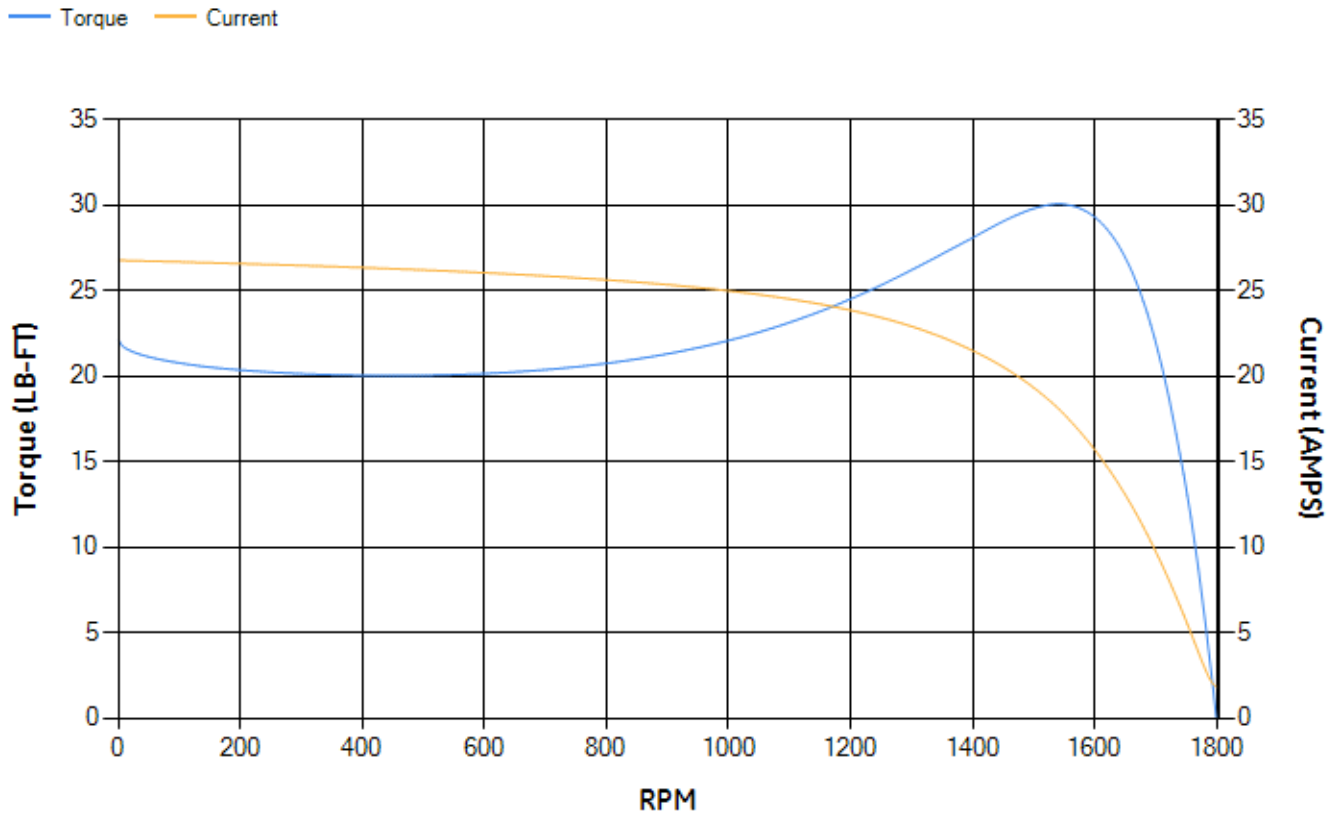

Marks:

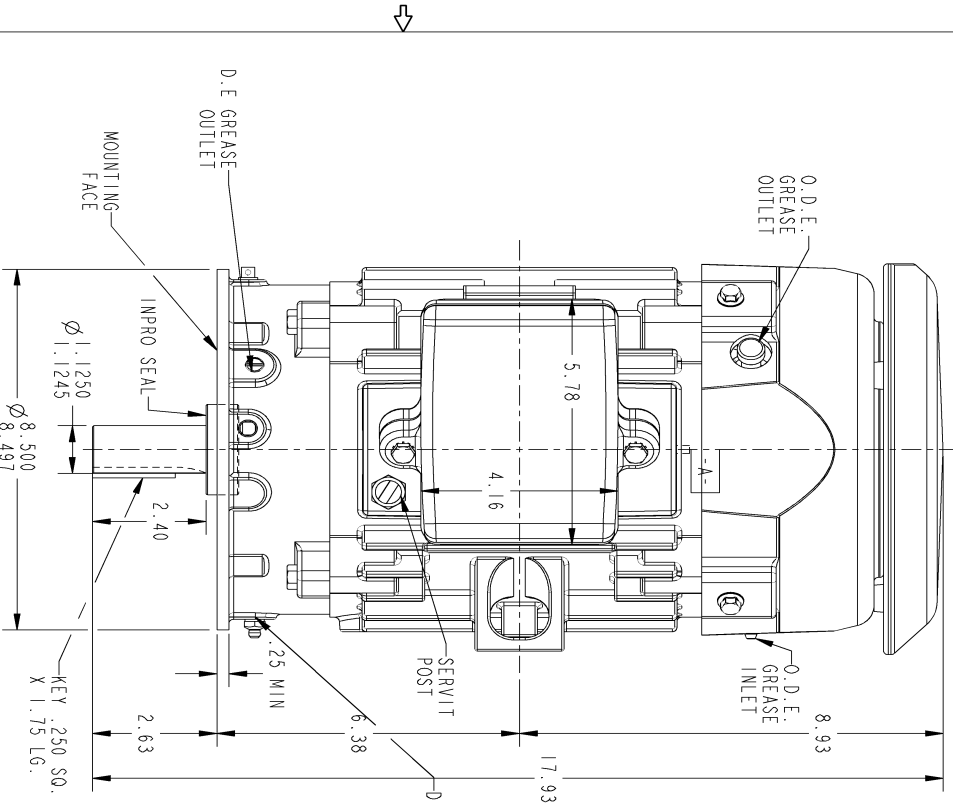

VIEW "A"

- NOTE 1: CONDUIT BOX MAY BE ASSEMBLED WITH ENTRANCE ON EITHER SIDE.
- NOTE 2: F1 ASSEMBLY AS SHOWN. F2 ASSEMBLY CONDUIT BOX ON OPPOSITE SIDE FROM SHOWN LOCATION.
- NOTE 3: MOUNTING SURFACES WILL BE SQUARE AND CONCENTRIC WITH SHAFT WITHIN .004 T.I.R.
- NOTE 4: SHAFT RUNOUT WILL NOT EXCEED .001 T.I.R.

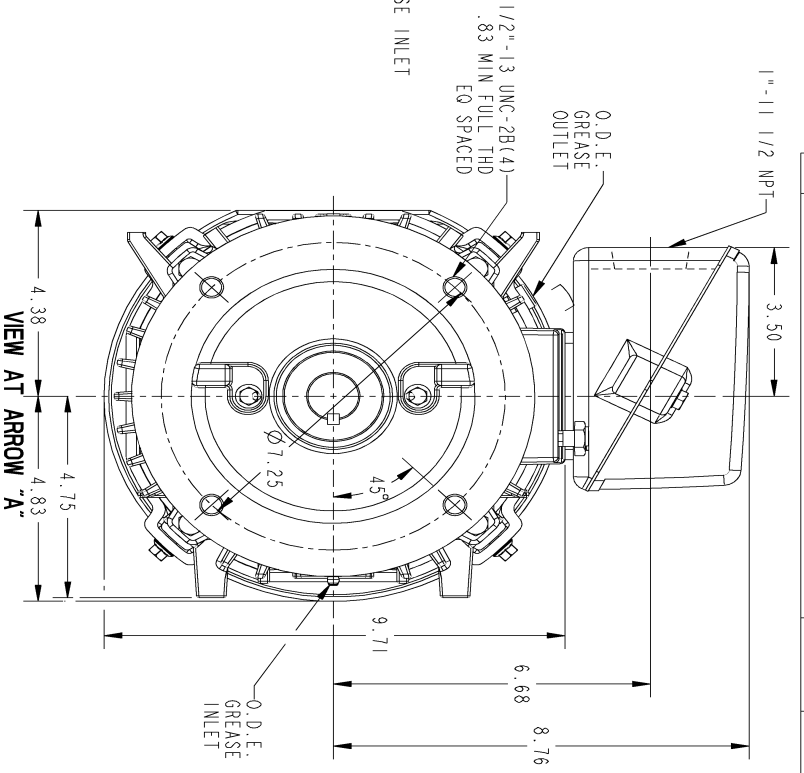
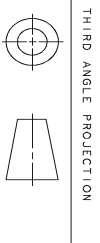

VIEW AT ARROW "A"

SIZE B DRAWING NO. 4002B5818PDP5310 SH 4 REV

REVISIONS		DATE	APPROVED
REV. 1	1" NPT WAS 3/4" NPT N PRASAD	10/9/06	ROOPA
2	REVISED AS PER THE ISAC # 09-0339	04/07/09	DAN
3	ISAC # 10-0924	07/29/11	RAGHU
4	ISAC # 14-0626	08/01/2014	VI JAY

SIGNATURES	DATE	DESCRIPTION
DRMAN AMAND 05/09/10		
DESIGNER DODDHAN 05/09/10		
ENGRG ENGRG		
ISSUED DODDHAN 05/09/10		
APPLIED PRACTICES		

**INDUCTION MOTOR OUTLINE**  
 IEEE-941 SPEC C FACE AT DE FOOTLESS WITH DRIP COVER  
 FME: 5KS182XAB226 (850° RABBIT)  
**4002B5818PDP5310**  
 SCALE: 0.400 REF. NO: -  
 SHEET 0F 1

DISTRIBUTION: PMP-18K15

Marks:

**Connection Diagram**  
**GEM2034E-FIG1**

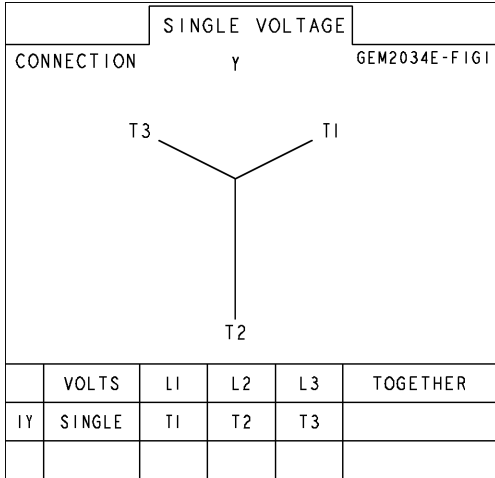

End shield Assembly		
Part Description	DE Side Part#	ODE Side Part#
End Shield	4004D5286PE1	4004D5281SG1
Bearing	235A2601AA01	235A2602AA01
Slinger/Inproseal	316A5384AJ1	4002B5914AG2

Fan & Fan Cover Assembly	
Part Description	Part#
Fan	346L620AN-G01
Fan Cover	4003C5518BN-G01

Conduit & Accessories Box Assembly	
Part Description	Part#
Conduit Box	4002B5721PA-G01

Mechanical Accessories	
Part Description	Part#
Brake	
Tachometer	