

DATE
February 18, 2004

OUTLINE DIMENSIONS

MOTOR TYPE:
ASGAJP

CATALOG NO.
DJPO106

3-PHASE INDUCTION MOTOR

FRAME NO. 256JP

Pole	HP	kW	Hz	VOLT	Syn. Speed r/min(rpm)
6	10	7.5	60	230/460	1200
Ins	Rating	Dimension in	Approx Weight	Bearings	
F	CONT.	inches	243 lbs.	DE: 6309ZZC3 NDE: 6208ZZC3	

Open Protected Drip-Proof Squirrel-Cage Rotor.

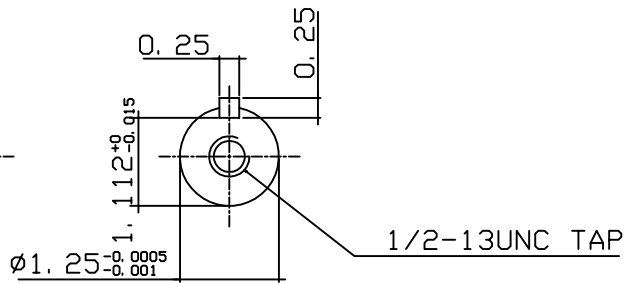
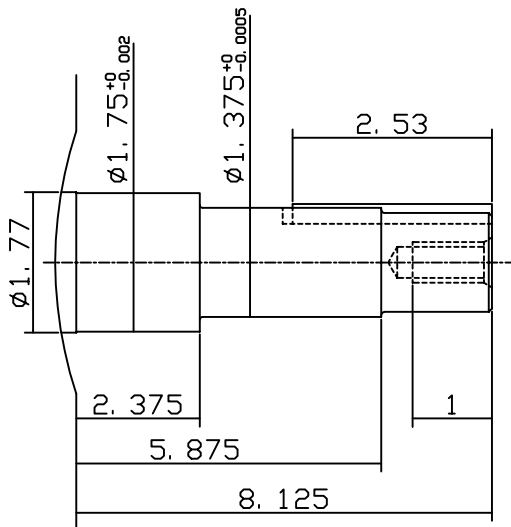
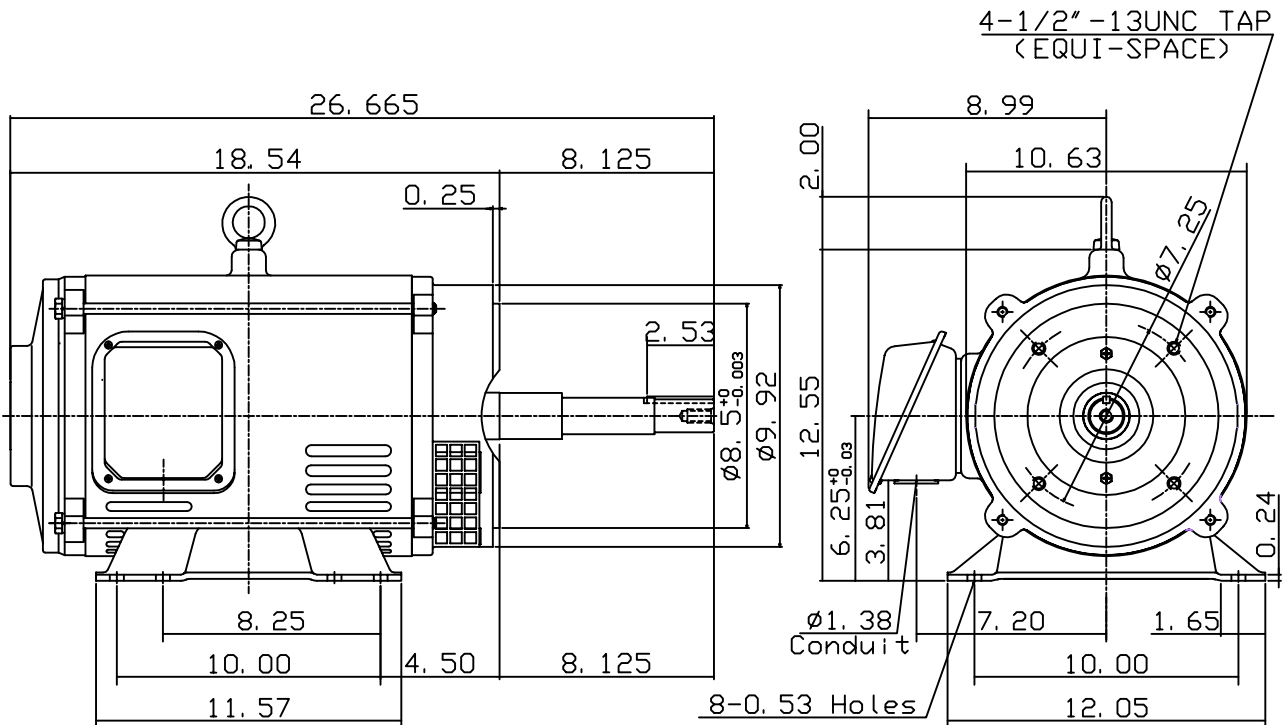

DWN.	J. T. HWANG	04-11-03
CHKD.	J. S. JEAN	04-11-03
APPD.	Y. B. HUANG	04-11-03

TEC Westinghouse

DWG NO.
31049U528525