

ROTATION
BI-DIRECTIONAL
SEE NOTE 6

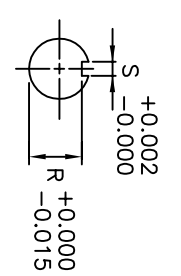
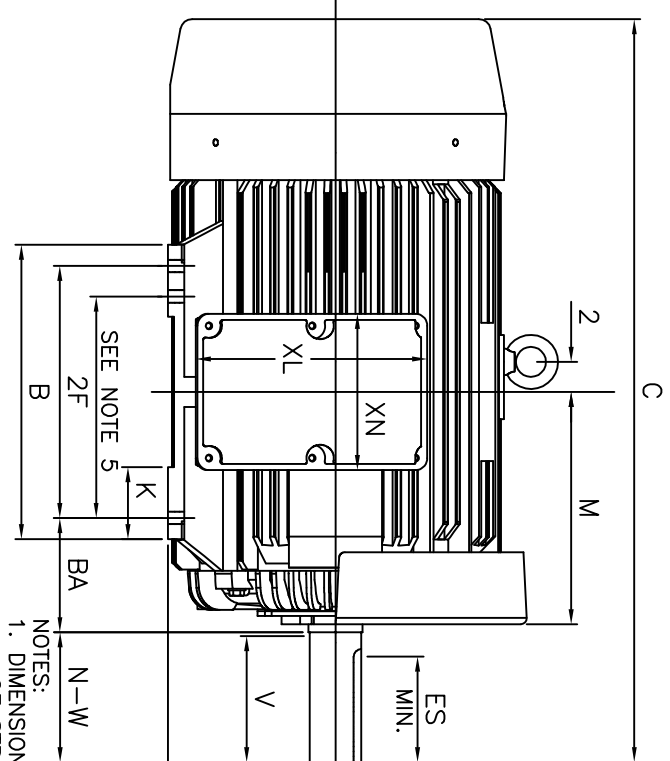
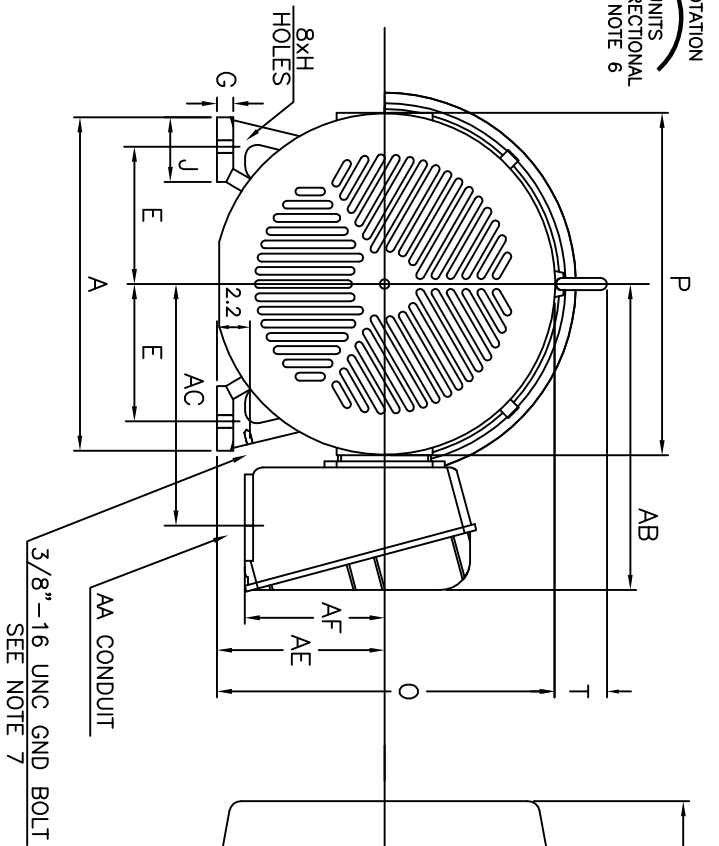

UNITS: INCHES

FRAME SIZE	MOTOR DIMENSIONS										CONDUIT BOX							
	A	B	C	D	G	J	K	M	O	P	T	AA[PT]	AB	AC	AE	AF	XL	XN
444T/445T	21.9	19.3	48.7	11.00	1.1	4.3	4.8	15.8	22.0	22.4	3.6	3.00	20.2	15.9	11.00	9.2	15.2	10.3

FRAME SIZE	MOUNTING				SHAFT EXTENSION				KEY SEAT			BEARINGS			MAXIMUM WEIGHT
	E	2F	H	BA	N-W	V	U	R	S	ES	LS	OS			
444T/445T	9.00	14.50/16.50	0.81	7.50	8.50	8.25	3.375	2.880	0.875	6.88	NU318C3	6318C3	2000 lbs.		

CUSTOMER: _____ MOTOR MODEL NO.: _____ TAG NO's: _____

P.O. NO.: _____ HP: _____ VOLTAGE: _____ RPM(SYN.): _____ HZ: _____
 FRAME SIZE: _____ PRODUCT TYPE: EOP III 840 & 841

COMMENTS: _____

 PER: _____ DATE: _____

TOSHIBA RESERVES THE RIGHT TO MAKE CHANGES OF TECHNICAL IMPROVEMENT AND THE DATA MAY CHANGE WITHOUT NOTICE PRELIMINARY
 DO NOT USE FOR CONSTRUCTION, INSTALLATION, OR APPLICATION PURPOSES UNLESS THE DRAWING IS MARKED AS CERTIFIED CERTIFIED

STANDARD (NO AUX. BOXES)
 RTD AUX. BOX
 SPACE HEATER AUX. BOX
 BEARING RTD's

- NOTES:
 1. DIMENSION V REPRESENTS LENGTH OF STRAIGHT PART OF SHAFT
 2. MAIN CONDUIT BOX MAY BE ROTATED IN 90° INCREMENTS
 3. KEY DIMENSIONS EQUAL S x S x 6.91 (MOTOR SUPPLIED WITH KEY)
 4. MOTOR WEIGHT SHOWN IS MAXIMUM HORSEPOWER IN FRAME
 5. THIS DIMENSION EQUALS 2F FOR 444T MOUNTING
 6. STANDARD PRODUCT USE BI-DIRECTIONAL FAN, OPPOSITE ROTATION AVAILABLE ONLY BY CONNECTION CHANGE
 7. FRAME GROUND BOLT STANDARD ON 841 PRODUCT

TOSHIBA
 TOSHIBA INTERNATIONAL CORPORATION

TOTALLY-ENCLOSED FAN-COOLED
 HORIZONTAL FOOT-MOUNTED
 3 PHASE INDUCTION MOTOR
 F1 ASSEMBLY

XT SERIES
 VISIT OUR WEBSITE AT:
 www.toshiba.com/ind