

# Product Information Packet

November 9, 2016

Data shown is for the current revision model #. Ensure your nameplate model # matches.

<b>Model Number:</b>	<b>5KS184SAA300D</b>
<b>Catalog Number:</b>	<b>M9948</b>
<b>Instruction Manual:</b>	GEI-56128
<b>Connection Diagram:</b>	GEM2034E-FIG1
<b>Outline Drawing:</b>	4002B5818PBP5316

<b>Accessory Connection Diagrams</b>			
<b>Bearing Thermocouple:</b>	None	<b>Heater:</b>	None
<b>RTD:</b>	None	<b>Thermistor:</b>	None
<b>Thermostat:</b>	None	<b>Winding Thermocouple:</b>	None
<b>Bearing RTD:</b>	None		

## Table of Contents

Specification	01
Performance Characteristics	02
Outline Drawing	03
Connection Drawing(s)	04
Spare parts	05



**Marks:**

<b>MODEL NUMBER:</b>	<b>5KS184SAA300D</b>	<b>Estimated Weight:</b>	101 Lbs
<b>Outline Drawing:</b>	4002B5818PBP5316	<b>Time Rating:</b>	CONT
<b>Connection Diagram:</b>	GEM2034E-FIG1	<b>Enclosure:</b>	TEFC
<b>Instruction Book:</b>	GEI-56128	<b>Encl Construction:</b>	X\$D
<b>Design Code:</b>	18BD3002A	<b>Ambient Max(°C):</b>	40
<b>Type:</b>	KS	<b>Alt Ambient Max(°C):</b>	65
<b>Frame:</b>	184TC	<b>Insulation Class:</b>	H
<b>Phases:</b>	3	<b>NEMA Design:</b>	B
<b>Poles:</b>	6	<b>Nominal Efficiency:</b>	88.5 %
<b>Output Power:</b>	2HP 1.5KW	<b>Guaranteed Efficiency:</b>	87.5
<b>RPM:</b>	1170	<b>3/4 Load Efficiency:</b>	88.6
<b>Voltage:</b>	460	<b>KVA Code:</b>	L
<b>Hertz:</b>	60	<b>Max KVAR:</b>	1.2
<b>Amps - FL:</b>	3.0	<b>Power Factor:</b>	69.5
<b>Service Factor:</b>	1.25	<b>Bearing - DE:</b>	6307ZC3
<b>Alt Service Factor:</b>	1.00	<b>Bearing - ODE:</b>	6206ZC3

**Enclosure is Totally Enclosed Fan-Cooled**

**Stamped Nameplate Notes:**

SF AMPS 3.6  
 STAMP NP249A5564P051 AS BELOW:  
 MODEL:5KS184SAA300D S/N: XXX  
 CSA CERTIFIED CSA09.2216219 FOR EX NA IIC 200C GC  
 CL 1 ZONE2 AEX NA IIC 200C;CL 1 DIV2 GRP ABCD 200C  
 IN -25C <= AMB <= 40C, 1.0 SF ON SINE-WAVE PWR  
 SURF TEMP 200C AT 1.25SF ON SINE-WAVE PWR  
 OR 200C VT OR 200C CT OR 200C CHP PWM CONTROL  
 ALTERNATE RATING FOR PWM CONTROL 1.0SF 40C AMB  
 VT 0 - 60 HZ, CT 3-60 HZ, CHP 60-90 HZ.

**Additional Information:**

6P - T EXTN  
 STANDARD FLOOR MOUNT  
 C/BOX 30 CU IN-0.75 NPT  
 F1 CONDUIT BOX MOUNTING  
 "C" FACE AT DE ENDSHIELD  
 INPRO SEAL DE ONLY  
 OIL RESISTANT SLEEVING ON LEADS

**Performance Characteristics**

1st Winding 1st Connection

**Design: 18BD3002A**

**Marks:**

LOAD %	125.0	115.0	100.0	75.0	50.0	25.0	0.0
% EFF	87.5	87.94	88.63	88.62	87.32	81.03	0.00
% PF	74.91	73.13	71.47	61.5	48.65	29.78	5.57
AMPS	3.57	3.35	2.96	2.58	2.2	1.94	1.72

<b>TORQ(FL)#FT</b>	8.97	<b>TORQ(LR)%FL</b>	218.45	<b>TORQ(BD)%FL</b>	385.07
<b>AMPS(LR)</b>	22.55	<b>PF AT START</b>	0.46		

This motor is capable of two cold or one hot start with a maximum connected load inertia of 290 Lb-Ft Sq (12.21 Kg-meter Sq)at 100% voltage, where the load torque varies with the square of the speed. Acceleration time with maximum inertia and the above load type is 53 seconds. Safe stall time at 100% voltage is 117 seconds cold, 94 seconds hot. Rotor inertia is 0.41 Lb-Ft Sq (0.02 Kg-meter Sq).

<b>Open Circuit A-C:</b>	0.158	<b>Short Circuit D-C:</b>	0.008
<b>Short Circuit A-C:</b>	0.01	<b>X/R Ratio:</b>	3.192
<b>Stator Slots:</b>	36	<b>Rotor Slots:</b>	48

**Speed Torque Current Curve (First Connection, First Speed)**

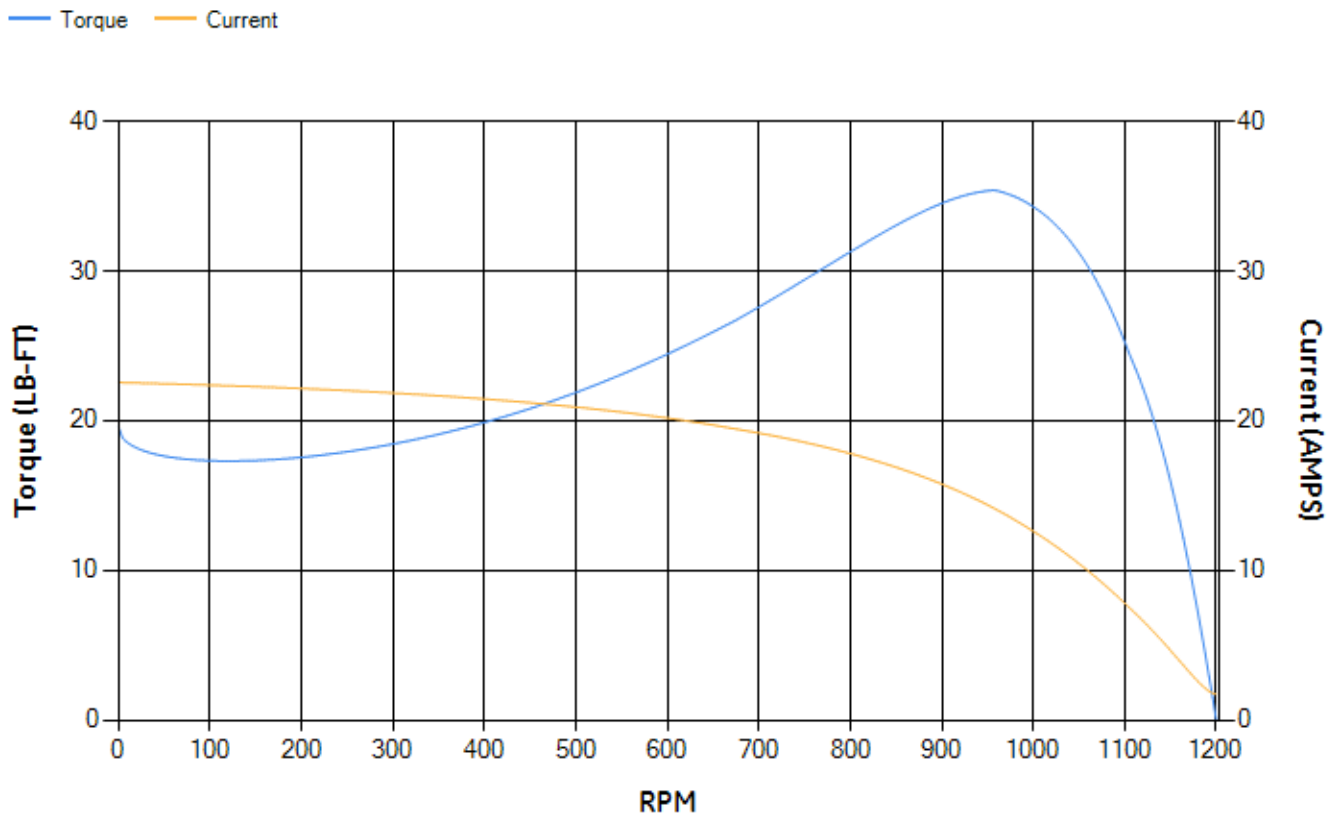

Marks:

NOTE 1: CONDUIT BOX MAY BE ASSEMBLED WITH ENTRANCE UP, DOWN OR TO EITHER SIDE.  
 NOTE 2: F1 ASSEMBLY AS SHOWN. F2 ASSEMBLY CONDUIT BOX ON OPPOSITE SIDE FROM SHOWN LOCATION.  
 NOTE 3: MOUNTING SURFACES WILL BE SQUARE AND CONCENTRIC WITH SHAFT WITHIN .004 T.I.R.  
 NOTE 4: SHAFT RUNOUT WILL NOT EXCEED .002 T.I.R.  
 NOTE 5: ALL DIMENSIONS ARE IN INCHES, BRACKETED DIMENSIONS ARE IN METRIC [MILLIMETERS].

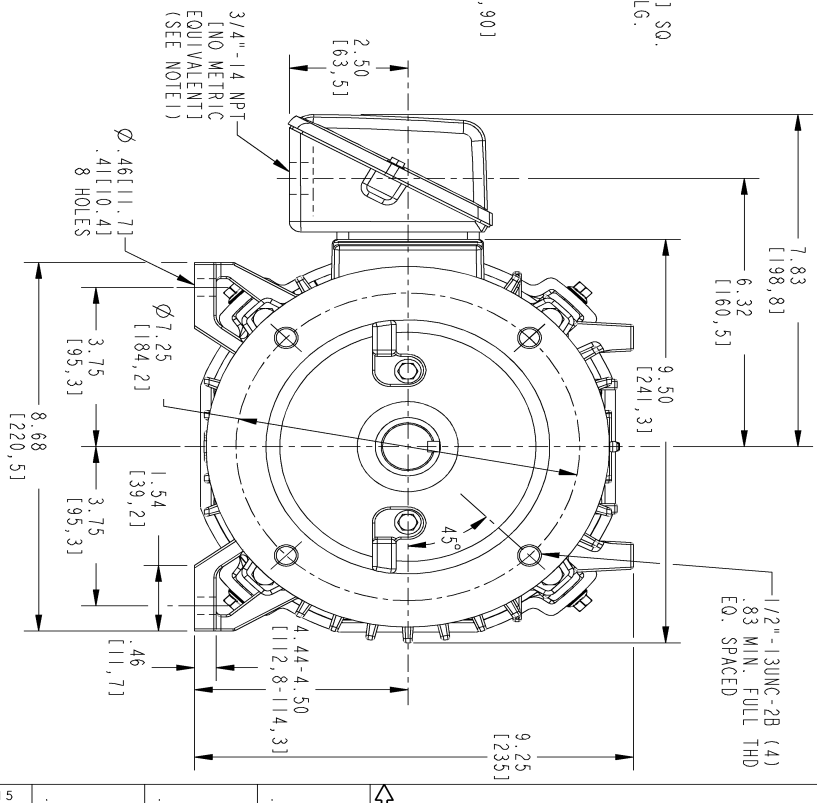
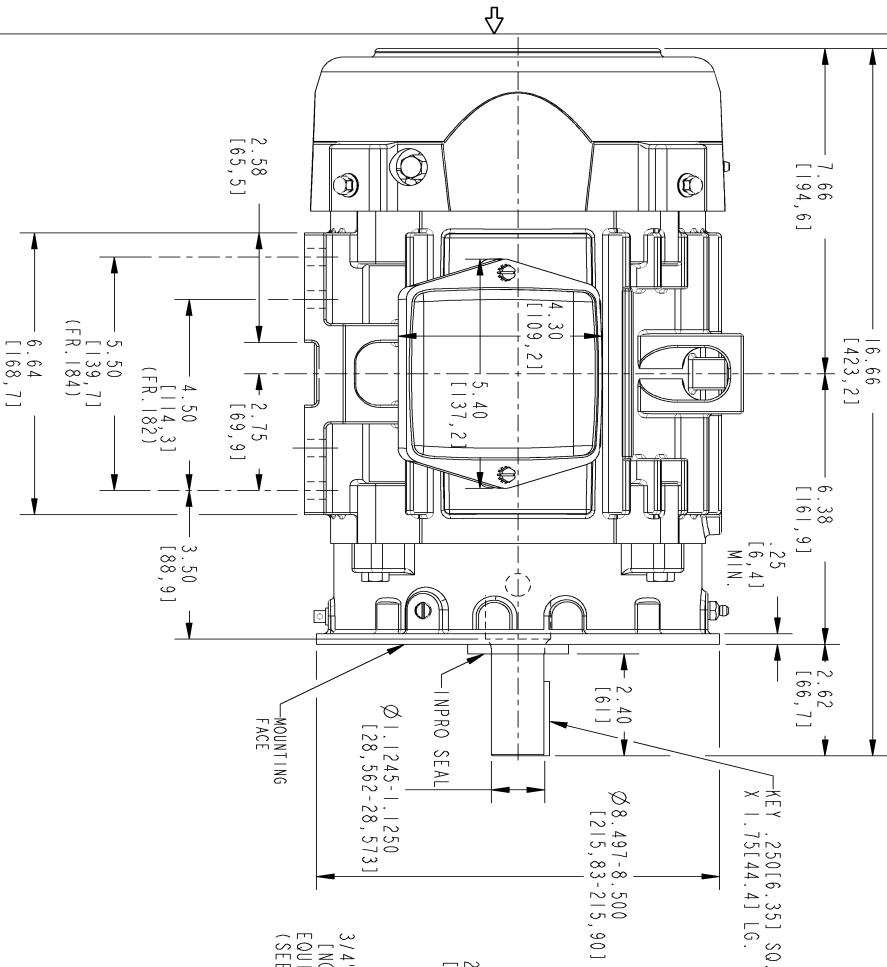

SIZE B DRAWING NO. 4002B5818PBP5316

REV.	DESCRIPTION	DATE	APPROVED
1	ISAAC #16-0864	08/30/16	VENKAT

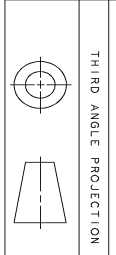

THIRD ANGLE PROJECTION

SIGNATURES	DATE	REVISIONS
DRMAN N PRASAD	04/23/16	
DESIGNED RAVI KUMAR	04/23/16	
ENGRG N PRASAD	04/23/16	
ISSUED N PRASAD	04/23/16	
APPLIED PRACTICES		

**GE Industrial Systems**  
**GENERAL ELECTRIC COMPANY**  
 Fort Wayne, Indiana

**INDUCTION MOTOR OUTLINE**  
 'C' FACE AT DE (850" RABBIT), WITH INPROSEAL  
 FWE: KS184TC TFC 'C' FACE

SIZE DRAWING 4002B5818PBP5316

SCALE: 0.400 REF. NO: 4002B5818PBP5301 SHEET 0F 1

DISTRIBUTION: PMP-18K15

Marks:

**Connection Diagram**  
**GEM2034E-FIG1**



End shield Assembly		
Part Description	DE Side Part#	ODE Side Part#
End Shield	4004D5286PE1	4004D5281SG1
Bearing	235A2601AA01	235A2602AA01
Slinger/Inproseal	316A5384AJ1	149C4399G16

Fan & Fan Cover Assembly	
Part Description	Part#
Fan	4001A5914AM-G01
Fan Cover	4003C5786PA1

Conduit & Accessories Box Assembly	
Part Description	Part#
Conduit Box	4002B5718PA-G01

Mechanical Accessories	
Part Description	Part#
Brake	
Tachometer	