

TYPE	OUTPUT		POLE	TIME RATING	VOLTAGE V	Hz	SYN SPEED R.P.M
	HP.	KW.					
ASHH	350	261	4	CDNT.	460	60	1800

DRIP PROOF TYPE, SQUIRREL-CAGE ROTOR

PRIMARY T-BOX

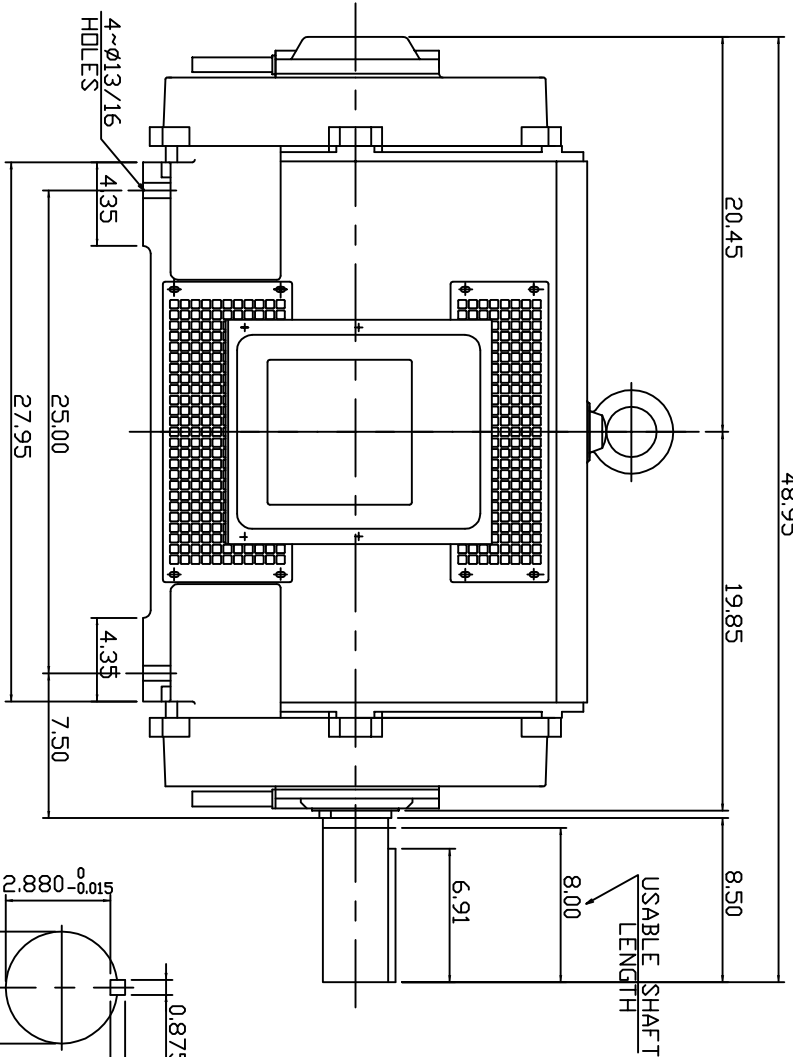
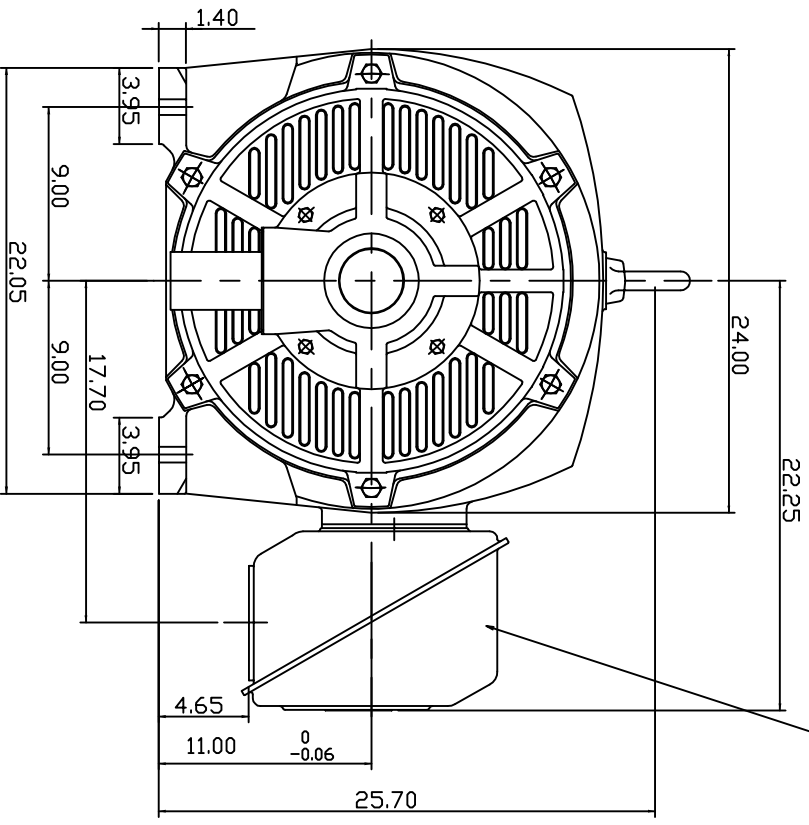

SHAFT END
[ENLARGE VIEW]

- NOTE:
 1. DIMENSIONS IN INCH
 2. FRAME NO. 449T
 3. F CLASS INSULATION
 4. FOR DIRECT FLEXIBLE COUPLING
 5. ENCLOSURE: IP22
 6. BEARING SIZE: DPP, DRIVE END 6320
 7. MOTOR APPROX. WEIGHT: 2310 LBS

TB-56SC

DWN.	HCHEN	JUL - 05 - 2010
CHKD.	W.V/ENG	JUL - 05 - 2010
APPD.	T.H/STAD	JUL - 05 - 2010

DATE	JULY 9, 2010	OUTLINE DIMENSIONS
CATALOG NO.	DHP3504	3-PHASE INDUCTION MOTOR



DWG NO. 3A049DTA0013-8
REV: 00