

TOSHIBA/HOUSTON

TOTALLY-ENCLOSED FAN-COOLED
HORIZONTAL FOOT-MOUNTED

Fr. N447TS-N449TS
DIRECT COUPLE
2 POLE

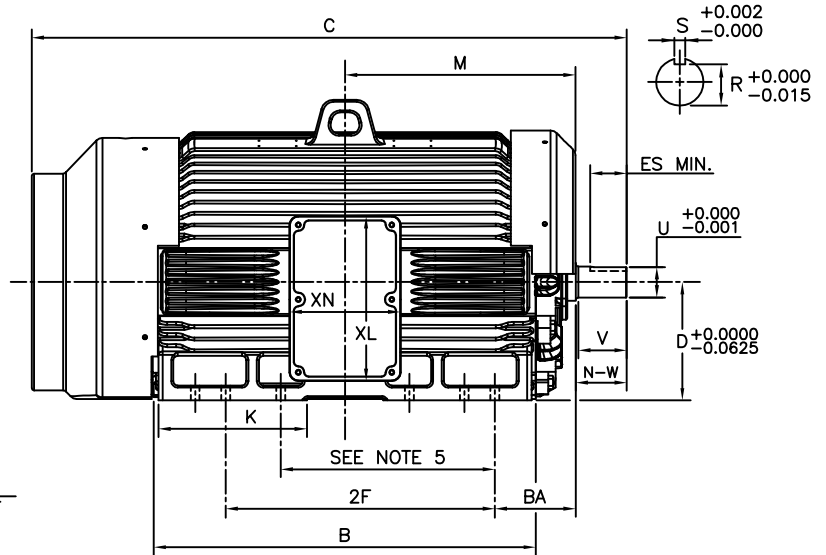
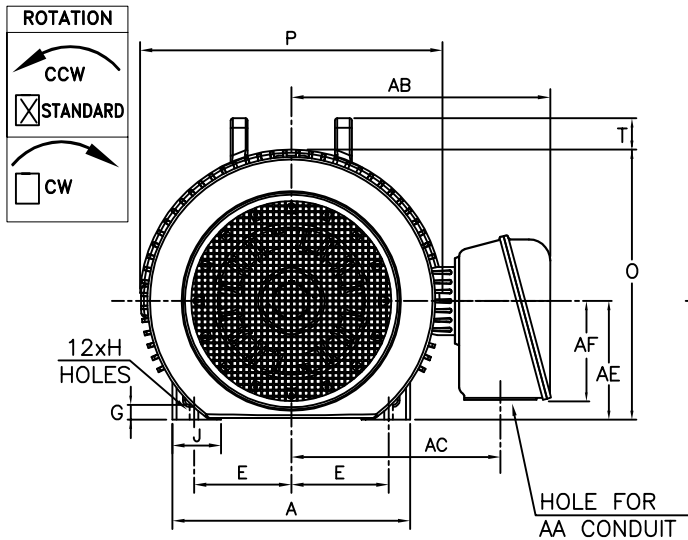

UNITS: INCHES

FRAME SIZE	MOUNTING				CONDUIT BOX						
	E	2F	H	BA	AA[NPT]	AB	AC	AE	AF	XL	XN
N447TS	9.00	20.00	0.81	7.50	4.00	24.0	19.4	11.0	9.2	15.3	10.3
N449TS	9.00	25.00	0.81	7.50	4.00	24.0	19.4	11.0	9.2	15.3	10.3

FRAME SIZE	MOTOR DIMENSIONS										
	A	B	C	D	G	J	K	M	O	P	T
N447TS	22.0	34.7	55.1	11.00	1.1	4.5	13.8	21.3	25.1	28.1	2.9
N449TS	22.0	34.7	55.1	11.00	1.1	4.5	13.8	21.3	25.1	28.1	2.9

FRAME SIZE	SHAFT EXTENSION			KEY SEAT			BEARINGS		MAXIMUM WEIGHT
	N-W	V	U	R	S	ES	LS	OS	
N447TS	4.75	4.50	2.375	2.021	0.625	3.00	6313C3	6313C3	3800 lbs.
N449TS	4.75	4.50	2.375	2.021	0.625	3.00	6313C3	6313C3	3800 lbs.

NOTES:

- DIMENSION V REPRESENTS LENGTH OF STRAIGHT PART OF SHAFT.
- CONDUIT BOX MAY BE ROTATED IN 90° INCREMENTS
- KEY DIMENSIONS EQUAL S x S x 3.00 (MOTOR SUPPLIED WITH KEY)
- MOTOR WEIGHT SHOWN IS MAXIMUM HORSEPOWER IN FRAME.
- DIMENSION FOR 447 MOUNTING EQUAL (2F) LOCATED IN 447 SIDE VIEW.
- STANDARD UNITS USE UNI-DIRECTIONAL FAN. OPPOSITE ROTATION AVAILABLE ONLY BY FAN AND CONNECTION CHANGE.

ALL DATA SUBJECT TO CHANGE WITHOUT NOTICE.
FOR CONSTRUCTION USE ONLY CERTIFIED DATA.

CERTIFIED DATA

CUSTOMER: _____ P.O. NO.: _____ TAG NO.: _____

MOTOR MODEL NO.: _____ TOSHIBA FILE NO.: _____

HP: _____ RPM (SYN.): _____ VOLTAGE: _____ Hz: _____

FRAME SIZE: _____ LOG NO.: _____ LOG REV. LEVEL: _____

REMARKS: _____

PER: _____ ISSUE DATE: _____ SUPERSEDES: _____