

Product Information Packet

November 8, 2016

Data shown is for the current revision model #. Ensure your nameplate model # matches.

Model Number:	5KS324XAA175D6
Catalog Number:	M8971
Instruction Manual:	GEI-56128
Connection Diagram:	GEM2034E-FIG7
Outline Drawing:	239C6001FS

Accessory Connection Diagrams			
Bearing Thermocouple:	None	Heater:	None
RTD:	None	Thermistor:	None
Thermostat:	None	Winding Thermocouple:	None
Bearing RTD:	None		

Table of Contents

Specification	01
Performance Characteristics	02
Outline Drawing	03
Connection Drawing(s)	04
Spare parts	05



Marks:

MODEL NUMBER:	5KS324XAA175D6	Estimated Weight:	620 Lbs
Outline Drawing:	239C6001FS	Time Rating:	CONT
Connection Diagram:	GEM2034E-FIG7	Enclosure:	TEFC
Instruction Book:	GEI-56128	Encl Construction:	841
Design Code:	32BD0110A	Ambient Max(°C):	40
Type:	KS	Alt Ambient Max(°C):	--
Frame:	324TSC	Insulation Class:	H
Phases:	3	NEMA Design:	B
Poles:	2	Nominal Efficiency:	93.0 %
Output Power:	40HP 29.6KW	Guaranteed Efficiency:	92.4
RPM:	3565	3/4 Load Efficiency:	92.8
Voltage:	460	KVA Code:	G
Hertz:	60	Max KVAR:	15.4
Amps - FL:	48.8	Power Factor:	82.5
Service Factor:	1.15	Bearing - DE:	6312ZC3
Alt Service Factor:	--	Bearing - ODE:	6312ZC3

Enclosure is Totally Enclosed Fan-Cooled

Stamped Nameplate Notes:

IEEE-STD-841-2009
 DE BRG 60BC03JP30, ODE BRG 60BC03JP30
 STAMP NP249A5564P051 AS BELOW:
 MODEL:5KS324XAA175D6 S/N: XXX
 CSA CERTIFIED CSA09.2216219 FOR EX NA IIC 200 C GC
 CL 1 ZONE2 AEX NA IIC 200C;CL 1 DIV2 GRP ABCD 200C
 IN -25C <= AMB <= 40C, 1.0 SF ON SINE-WAVE PWR
 SURF TEMP 260C AT 1.15SF ON SINE-WAVE PWR
 OR 200 C VT OR 230 C CT OR 200 C CHP PWM CONTROL
 ALTERNATE RATING FOR PWM CONTROL 1.0SF 40C AMB
 VT 0-60 HZ, CT 8.6-60 HZ, CHP 60-75 HZ.

Additional Information:

2P - TS EXTN
 PAINTED FRAME ID & SHAFT,
 FAN COVER INSIDE & ODE E/S OUTSIDE
 C FACE ON DE
 346 CU IN - 3.00" NPT
 INPRO SEAL BOTH ENDS
 OIL RESISTANT SLEEVING ON LEADS
 .0015" TIR SHAFT RUNOUT
 ROUTINE TEST REPORT AND 5 POINT VIBRATION TEST
 REPORT INCLUDED IN C/B
 COPPER WASHER UNDER HEADS OF BEARING CAP BOLTS,
 APPLY TITE-SEAL (A50CD427A) ON BEARING CAP SCREWS,
 RABBETS AND PLUG THREADS.
 GROUND PAD

F1 MOUNTING

TEFC XSD-841 ULTRA STOCK 06/28/2016

ENGINEERED BY: BALASUBRAMANIANH/DHEERAJB



Performance Characteristics

1st Winding 1st Connection

Design: 32BD0110A

Marks:

LOAD %	125.0	115.0	100.0	75.0	50.0	25.0	0.0
% EFF	92.48	92.68	93.08	92.81	91.71	87	0.00
% PF	84.94	84.16	82.43	77.19	66.33	44.05	5.62
AMPS	59.58	55.2	48.73	39.2	30.77	24.42	21.43

TORQ(FL)#FT	58.88	TORQ(LR)%FL	145.55	TORQ(BD)%FL	296.23
AMPS(LR)	300.37	PF AT START	0.29		

This motor is capable of two cold or one hot start with a maximum connected load inertia of 117 Lb-Ft Sq (4.93 Kg-meter Sq) at 100% voltage, where the load torque varies with the square of the speed. Acceleration time with maximum inertia and the above load type is 23 seconds. Safe stall time at 100% voltage is 52 seconds cold, 27 seconds hot. Rotor inertia is 3.14 Lb-Ft Sq (0.13 Kg-meter Sq).

Open Circuit A-C:	0.603	Short Circuit D-C:	0.017
Short Circuit A-C:	0.041	X/R Ratio:	6.429
Stator Slots:	48	Rotor Slots:	38

Speed Torque Current Curve (First Connection, First Speed)

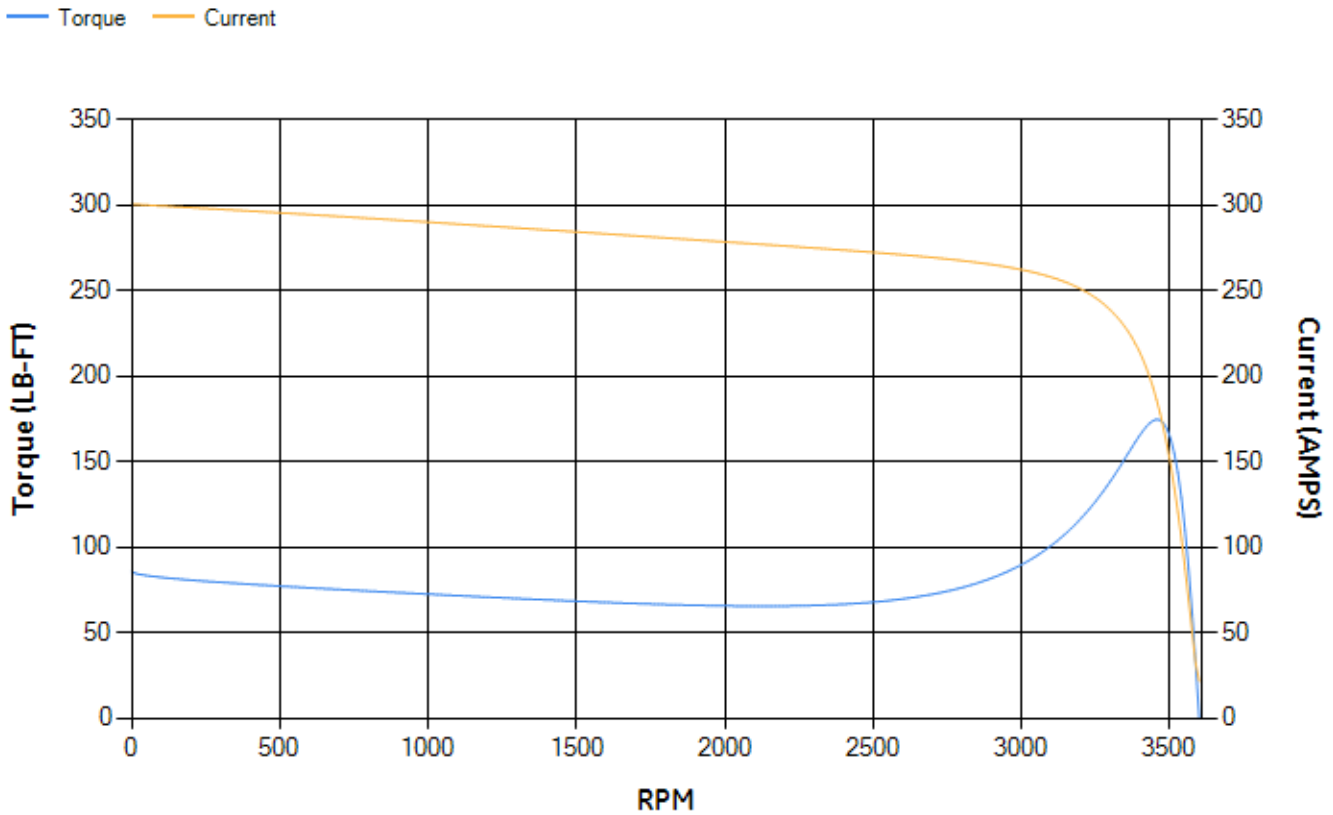

Marks:

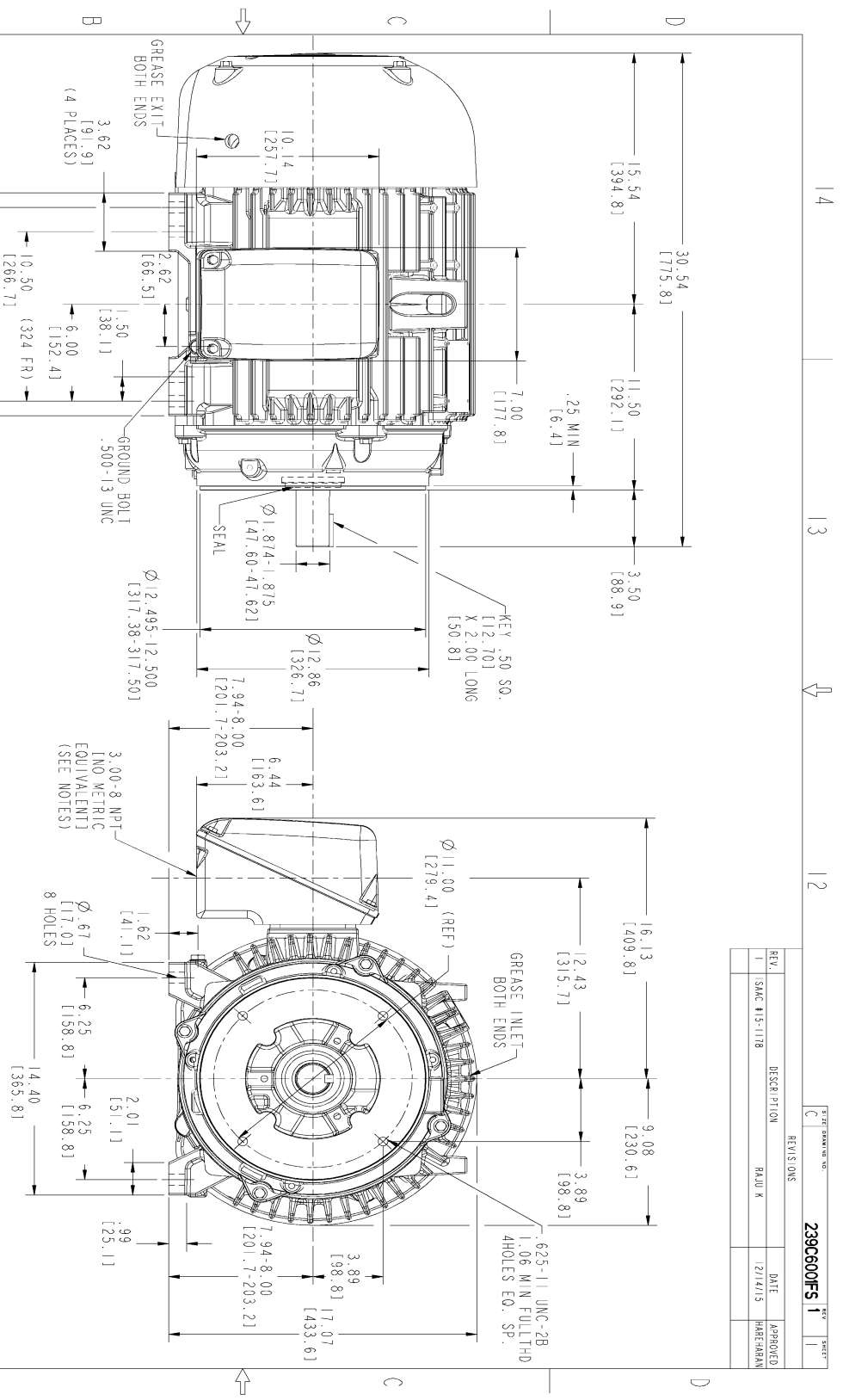

NOTES :

1. CONDUIT BOX MAY BE PLACED WITH THE ENTRANCE DOWN, UP OR ON EITHER SIDE.
2. F-1 ASM AS SHOWN.
3. F-2 ASM HAS CONDUIT BOX ON OPPOSITE SIDE.
4. BRACKETED DIMENSIONS ARE METRIC (MILLIMETERS).
5. TOLERANCE ON PERMISSIBLE SHAFT EXTENSION ROUNDOFF IS .0015 T.I.R.

SIZE DRAWING NO. 239C600FS 1		REV. 1	SHEET 1
REV. DESCRIPTION		DATE	APPROVED
1	SAC #15-1178 RAJUK	12/14/15	HAREHARAN

SIGNATURES		DATE	
MODEL	TEJASNI	06/26/15	
SCALE	TEJASNI	06/26/15	
TITLE			
GENERAL ELECTRIC COMPANY			
OUTLINE			
324/326 TSC TFC XSD-941			
346 CU IN CONDUIT BOX			
239C600FS			
REV. 1			
SCALE: 0.250		REF. NO.: 239C600 CR	
SHEET 1 OF 1			

Marks:

Connection Diagram
GEM2034E-FIG7

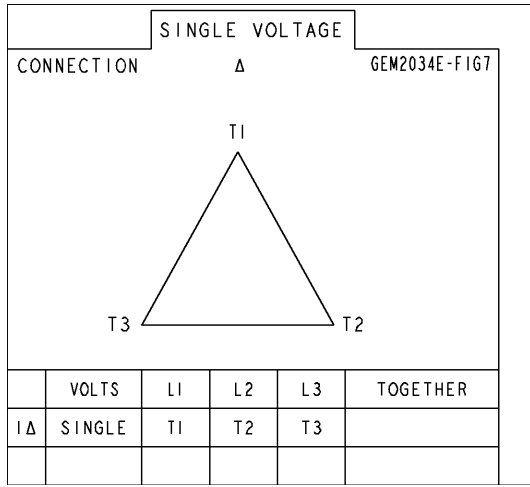

End shield Assembly		
Part Description	DE Side Part#	ODE Side Part#
End Shield	115E4203AA1	115E4200LA1
Bearing	235A2609AA01	235A2609AA01
Slinger/Inproseal	235A4575GS2	235A4575GS2

Fan & Fan Cover Assembly	
Part Description	Part#
Fan	159C6700G02
Fan Cover	128D6800AA1

Conduit & Accessories Box Assembly	
Part Description	Part#
Conduit Box	149C4429AA2

Mechanical Accessories	
Part Description	Part#
Brake	
Tachometer	