

Product Information Packet

April 28, 2017

Data shown is for the current revision model #. Ensure your nameplate model # matches.

Model Number:	5KS444XAJ6408A
Catalog Number:	V4826
Instruction Manual:	GEK-95351
Connection Diagram:	GEM2034E-FIG7
Outline Drawing:	148CB44INHRCCLA0001

Accessory Connection Diagrams

Bearing Thermocouple:	None	Heater:	None
RTD:	None	Thermistor:	None
Thermostat:	None	Winding Thermocouple:	None
Bearing RTD:	None		

Table of Contents

Specification	01
Performance Characteristics	02
Outline Drawing	03
Connection Drawing(s)	04
Spare parts	05



Marks:

MODEL NUMBER:	5KS444XAJ6408A	Estimated Weight:	2115 Lbs
Outline Drawing:	148CB44INHRCCCLA0001	Time Rating:	CONT
Connection Diagram:	GEM2034E-FIG7	Enclosure:	TEFC
Instruction Book:	GEK-95351	Encl Construction:	841
Design Code:	44BD1156AA	Ambient Max(°C):	40
Type:	KS	Alt Ambient Max(°C):	--
Frame:	L444VP16	Insulation Class:	H
Phases:	3	NEMA Design:	B
Poles:	4	Nominal Efficiency:	95.4 %
Output Power:	125HP 92.5KW	Guaranteed Efficiency:	95.0
RPM:	1785	3/4 Load Efficiency:	95.1
Voltage:	460	KVA Code:	G
Hertz:	60	Max KVAR:	39.8
Amps - FL:	146.0	Power Factor:	84.5
Service Factor:	1.15	Bearing - DE:	6217C3
Alt Service Factor:	--	Bearing - ODE:	235A2536AB01

Enclosure is Totally Enclosed Fan-Cooled

Stamped Nameplate Notes:

IEEE-STD-841-2009
 VERTICAL 841
 DE BRG 85BC02J30, ODE BRG 130BT03MD00
 INVERTER DUTY PER NEMA MG1 PART 31
 ALTERNATE RATING FOR PWM CONTROL:1.0SF 40C AMBIENT
 VAR TORQUE RANGE 0-60 HZ
 GE SELF DECLARED CLASS I DIV 2 MOTOR
 MAX EXPOSED INTERNAL AND EXTERNAL SURFACE
 TEMPERATURES UNDER USUAL SERVICE CONDITIONS
 AT 1.00 S.F. DO NOT EXCEED 200 DEG C
 API 610 12TH EDITION SHAFT DIMENSIONS

Additional Information:

4 POLE,VERT SOLID SHAFT HIGH THRUST (1D)
 PAINTED FRAME ID & SHAFT,
 FAN COVER INSIDE & ODE E/S OUTSIDE
 700 CU IN - 3.00" NPT
 BEARING LIFE 8760 HRS AT 13095 LB THRUST
 BEARING LIFE 26280 HRS AT 9706 LB THRUST
 INPRO SEAL LOWER END
 OIL RESISTANT SLEEVING ON LEADS
 ROUTINE TEST REPORT AND 5 POINT VIBRATION TEST
 REPORT INCLUDED IN C/B
 COPPER WASHER UNDER HEADS OF BEARING CAP BOLTS,
 APPLY TITE-SEAL (A50CD427A) ON BEARING CAP SCREWS,
 RABBETS AND PLUG THREADS.
 STAINLESS STEEL T-DRAIN.



FRAME GROUND PAD
ACTUAL EFFICIENCY =
RCF: XXXX CPM AT C/BOX SIDE, XXXX CPM AT
90 DEG FROM C/ BOX SIDE

Performance Characteristics

1st Winding 1st Connection

Design: 44BD1156AA

Marks:

LOAD %	125.0	115.0	100.0	75.0	50.0	25.0	0.0
% EFF	94.53	94.69	95.04	94.82	94.07	90.65	0.00
% PF	86.4	85.9	84.68	80.57	71.17	49.06	4.81
AMPS	179.06	165.41	145.37	114.84	87.38	65.77	55.48

TORQ(FL)#FT	368.16	TORQ(LR)%FL	180.98	TORQ(BD)%FL	277.24
AMPS(LR)	903.77	PF AT START	0.32		

This motor is capable of two cold or one hot start with a maximum connected load inertia of 1875 Lb-Ft Sq (78.94 Kg-meter Sq)at 100% voltage, where the load torque varies with the square of the speed. Acceleration time with maximum inertia and the above load type is 23 seconds. Safe stall time at 100% voltage is 55 seconds cold, 27 seconds hot. Rotor inertia is 47.92 Lb-Ft Sq (2.02 Kg-meter Sq).

Open Circuit A-C:	0.684	Short Circuit D-C:	0.028
Short Circuit A-C:	0.038	X/R Ratio:	10.605
Stator Slots:	72	Rotor Slots:	58

Speed Torque Current Curve (First Connection, First Speed)

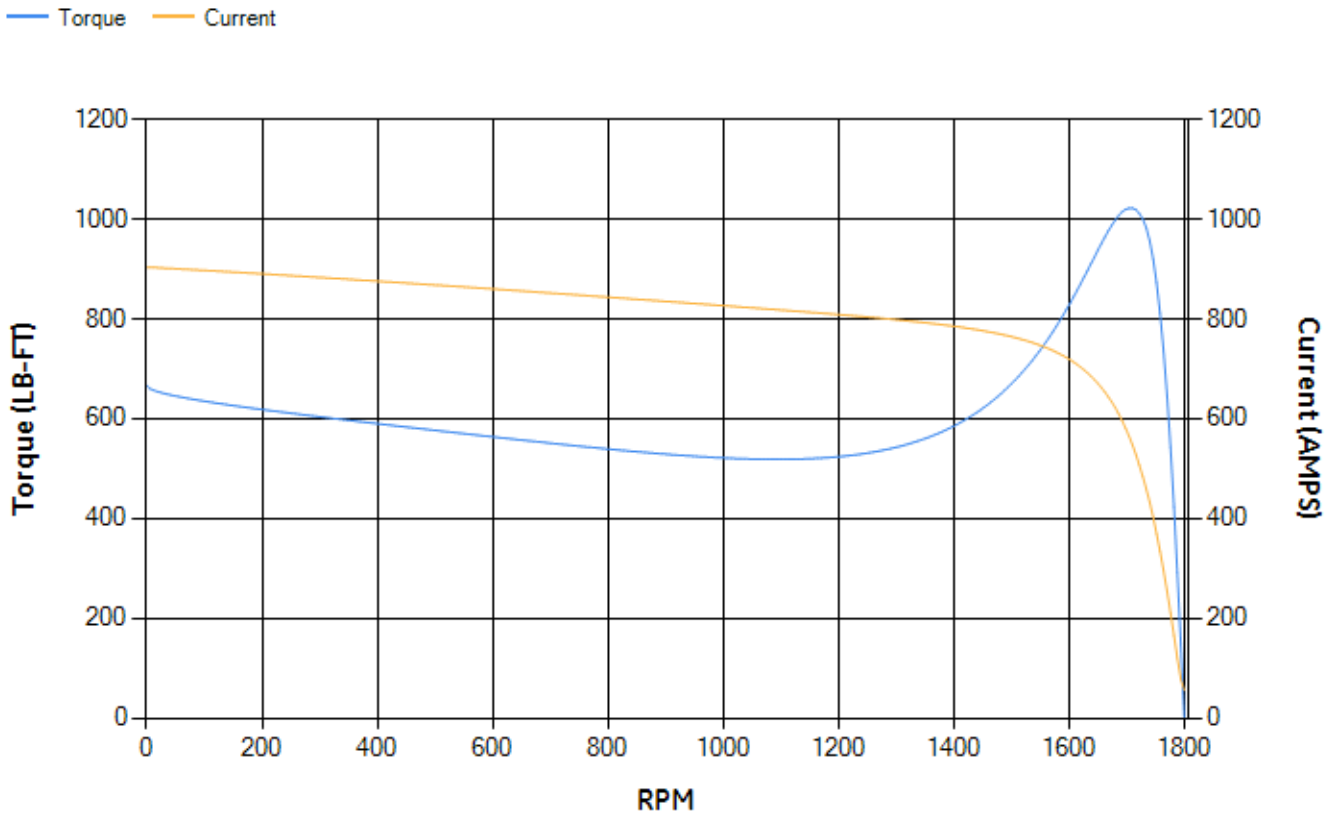

Marks:

SOLID MODEL: 148CB441NHRCLA0001

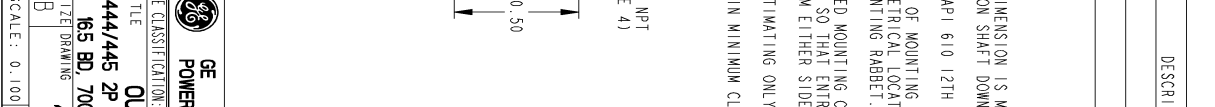
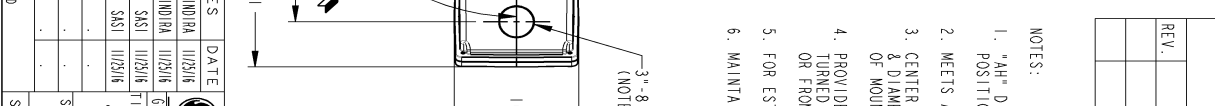
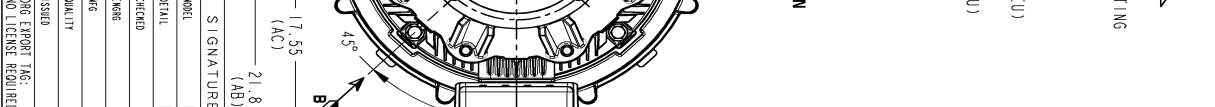
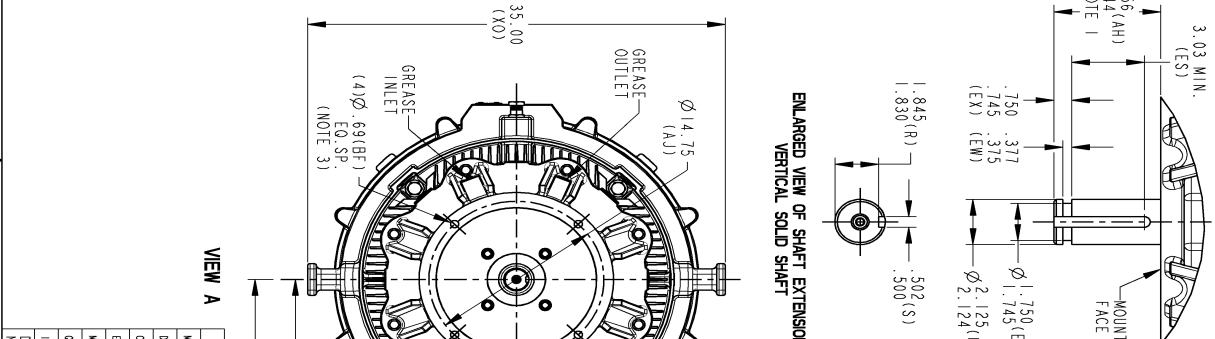
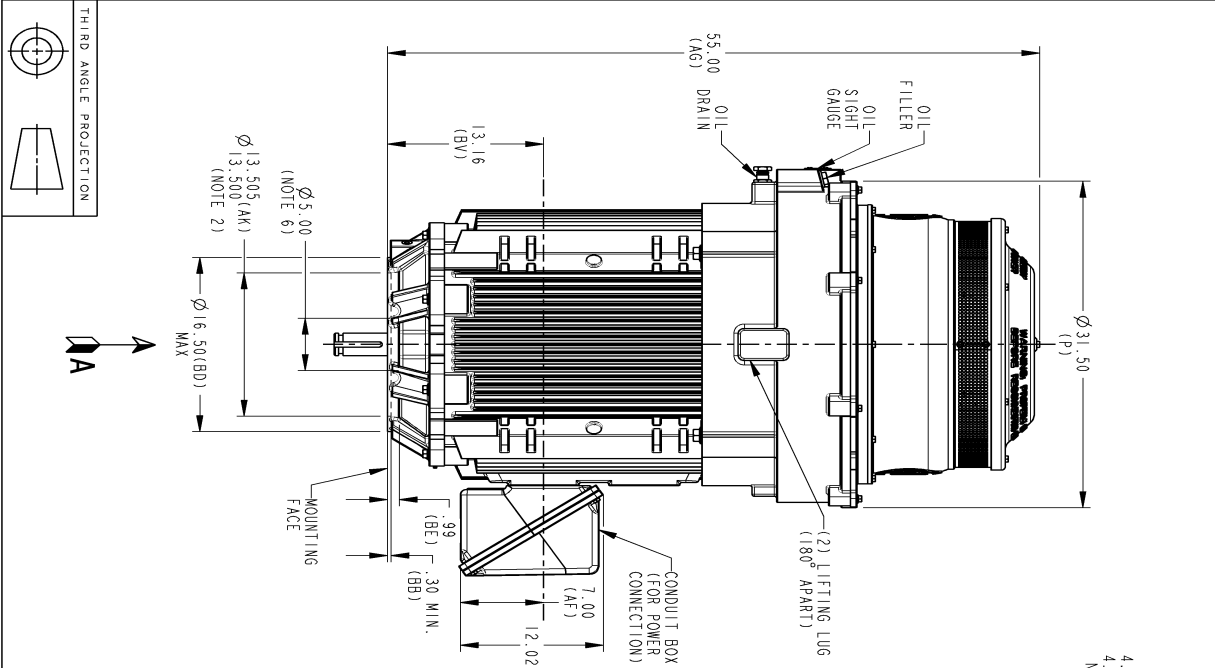

NOTES:

- *AH* DIMENSION IS MEASURED WITH MOTOR IN VERTICAL POSITION SHAFT DOWN.
- MEETS API 610 12TH EDITION SHAFT DIMENSIONS.
- CENTER OF MOUNTING BOLTS HOLES WITHIN .025 OF ANGULAR & DIAMETRICAL LOCATION WITHIN REFERENCE TO THE CENTERLINE OF MOUNTING RABBET.
- PROVIDED MOUNTING CONDITIONS PERMIT, CONDUIT BOX MAY BE TURNED SO THAT ENTRANCE CAN BE MADE UPWARD, DOWNWARD OR FROM EITHER SIDE.
- FOR ESTIMATING ONLY UNLESS ENDORSED FOR CONSTRUCTION.
- MAINTAIN MINIMUM CLEARANCE FOR SHAFT SLINGER.

REV.	DESCRIPTION	DATE	APPROVED

148CB441NHRCLA0001	000	REV	1	SHEET	1
--------------------	-----	-----	---	-------	---

SIGNATURES	DATE	REV	DESCRIPTION
DESIGNED: SAS1 11/29/16	11/29/16		
CHECKED: SAS1 11/29/16	11/29/16		
ENG'G: SAS1 11/29/16	11/29/16		
ISSUED:			
DWG EXPORT TAG:			
NO LICENSE REQUIRED			

148CB441NHRCLA0001	000	REV	1	SHEET	1
--------------------	-----	-----	---	-------	---

Marks:

Connection Diagram
GEM2034E-FIG7



End shield Assembly		
Part Description	DE Side Part#	ODE Side Part#
End Shield	115E8660AA1	115E8670LA1
Bearing	235A2522AJ01	235A2536AB01
Slinger/Inproseal	235A4575GS4	

Fan & Fan Cover Assembly	
Part Description	Part#
Fan	159C7100AA2
Fan Cover	128D6847AA1

Conduit & Accessories Box Assembly	
Part Description	Part#
Conduit Box	118D4408AD2

Mechanical Accessories	
Part Description	Part#
Brake	
Tachometer	