

Product Information Packet

January 12, 2017

Data shown is for the current revision model #. Ensure your nameplate model # matches.

Model Number:	5KS286CAA204D
Catalog Number:	E9632
Instruction Manual:	GEI-56128
Connection Diagram:	GEM2034E-FIG7
Outline Drawing:	4002B5828RAP5201

Accessory Connection Diagrams			
Bearing Thermocouple:	None	Heater:	None
RTD:	None	Thermistor:	None
Thermostat:	3027JE-2A	Winding Thermocouple:	None
Bearing RTD:	None		

Table of Contents

Specification	01
Performance Characteristics	02
Outline Drawing	03
Connection Drawing(s)	04
Spare parts	05



Marks:

MODEL NUMBER:	5KS286CAA204D	Estimated Weight:	510 Lbs
Outline Drawing:	4002B5828RAP5201	Time Rating:	CONT
Connection Diagram:	GEM2034E-FIG7	Enclosure:	TEFC
Instruction Book:	GEI-56128	Encl Construction:	XP
Design Code:	28BD1157B	Ambient Max(°C):	40
Type:	KS	Alt Ambient Max(°C):	--
Frame:	286T	Insulation Class:	F
Phases:	3	NEMA Design:	B
Poles:	4	Nominal Efficiency:	93.6 %
Output Power:	30HP 22.2KW	Guaranteed Efficiency:	92.4
RPM:	1775	3/4 Load Efficiency:	94.1
Voltage:	575	KVA Code:	G
Hertz:	60	Max KVAR:	8.2
Amps - FL:	27.9	Power Factor:	86.0
Service Factor:	1.00	Bearing - DE:	6310ZC3
Alt Service Factor:	--	Bearing - ODE:	6310ZC3

Enclosure is Totally Enclosed Fan-Cooled

Stamped Nameplate Notes:

EXPLOSION PROOF MOTOR
TEMP CODE T3C
THERMOSTAT LEADS TB1-TB2
STAMP NP249A5571AD "CL I (C & D) CL II (F & G)"

Additional Information:

4P - T EXTN
STANDARD FLOOR MOUNT
C/BOX 250 CU IN-2.00 NPT
F1 CONDUIT BOX MOUNTING
AUX LEADS EXIT WITH MOTOR LEADS
CL I C & D CL II F & G EXPLOSION PROOF MOTOR

Performance Characteristics

1st Winding 1st Connection

Design: 28BD1157B

Marks:

LOAD %	125.0	115.0	100.0	75.0	50.0	25.0	0.0
% EFF	92.44	92.88	93.64	94.08	94.05	91.76	0.00
% PF	86.96	86.8	86.12	83.12	75.24	54.04	4.52
AMPS	34.93	32.04	27.84	21.54	15.87	11.32	9.11

TORQ(FL)#FT	88.63	TORQ(LR)%FL	183.04	TORQ(BD)%FL	279.67
AMPS(LR)	171.25	PF AT START	0.38		

This motor is capable of two cold or one hot start with a maximum connected load inertia of 962 Lb-Ft Sq (40.5 Kg-meter Sq) at 100% voltage, where the load torque varies with the square of the speed. Acceleration time with maximum inertia and the above load type is 51 seconds. Safe stall time at 100% voltage is 91 seconds cold, 62 seconds hot. Rotor inertia is 5.44 Lb-Ft Sq (0.23 Kg-meter Sq).

Open Circuit A-C:	0.635	Short Circuit D-C:	0.016
Short Circuit A-C:	0.027	X/R Ratio:	5.902
Stator Slots:	48	Rotor Slots:	40

Speed Torque Current Curve (First Connection, First Speed)

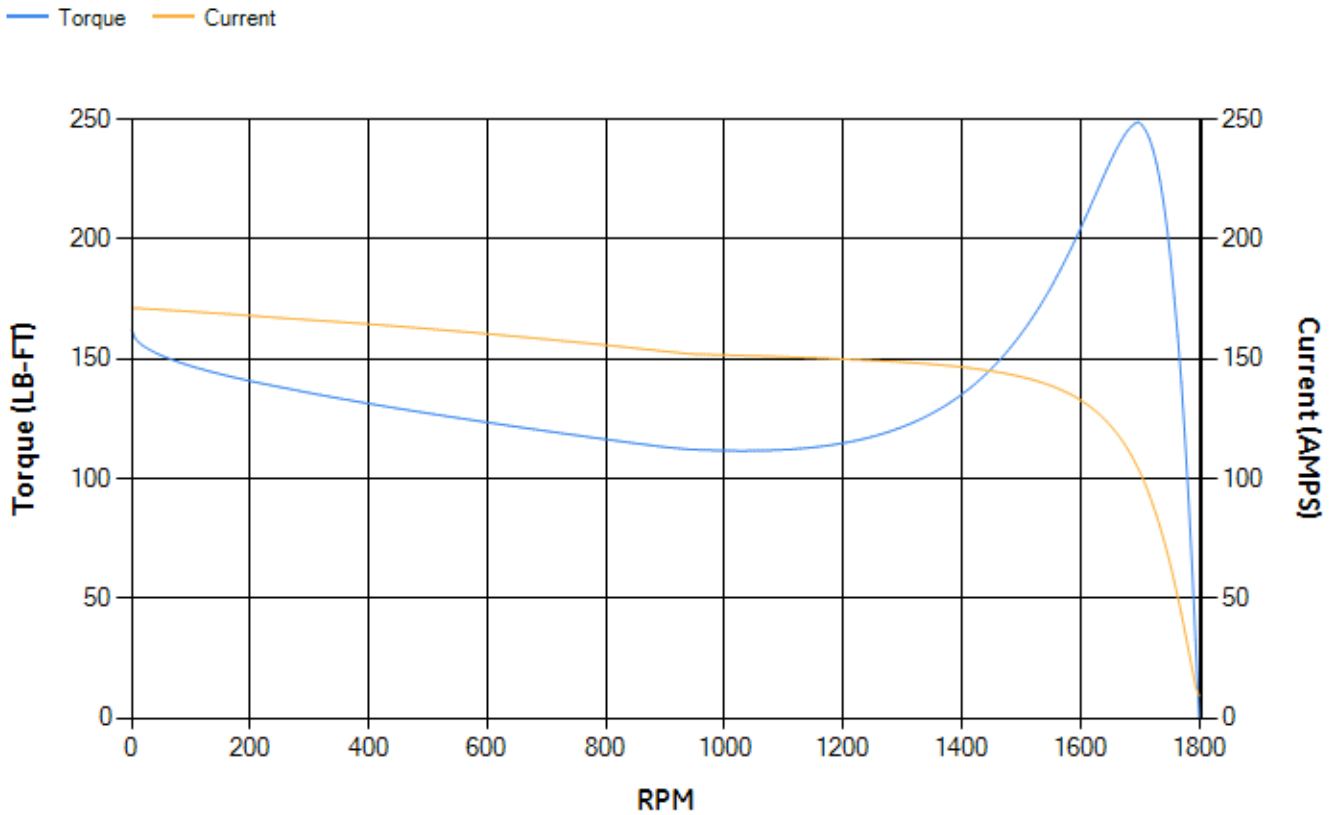

NAME:320002276 OBJECT:4002B5828RAP5201 DATE:19-Feb-09 13:17:55

Marks:

NOTE 1 : CONDUIT BOX MAY BE ASSEMBLED WITH ENTRANCE UP, DOWN OR TO EITHER SIDE.
 NOTE 2 : F1 ASSEMBLY AS SHOWN. F2 ASSEMBLY CONDUIT BOX ON OPPOSITE SIDE FROM SHOWN LOCATION.

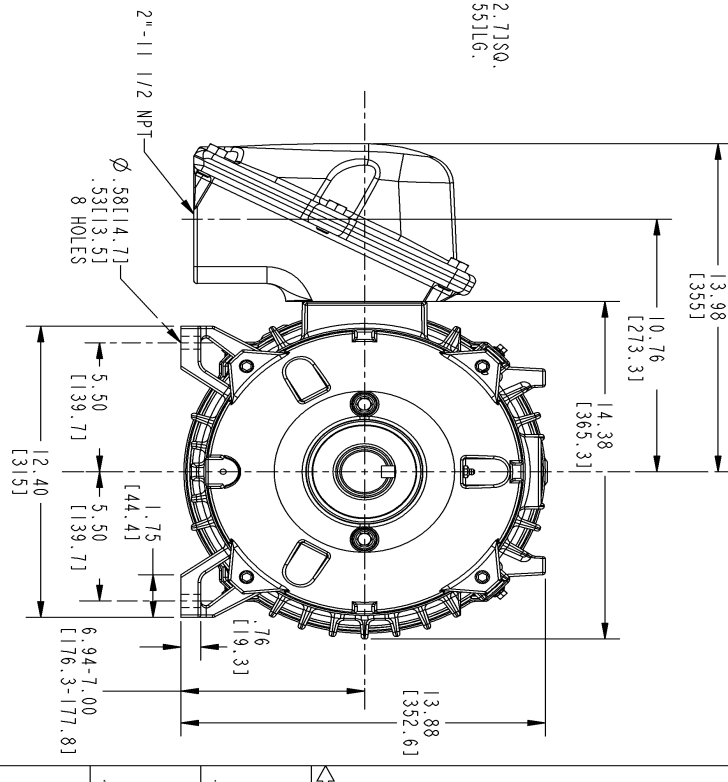
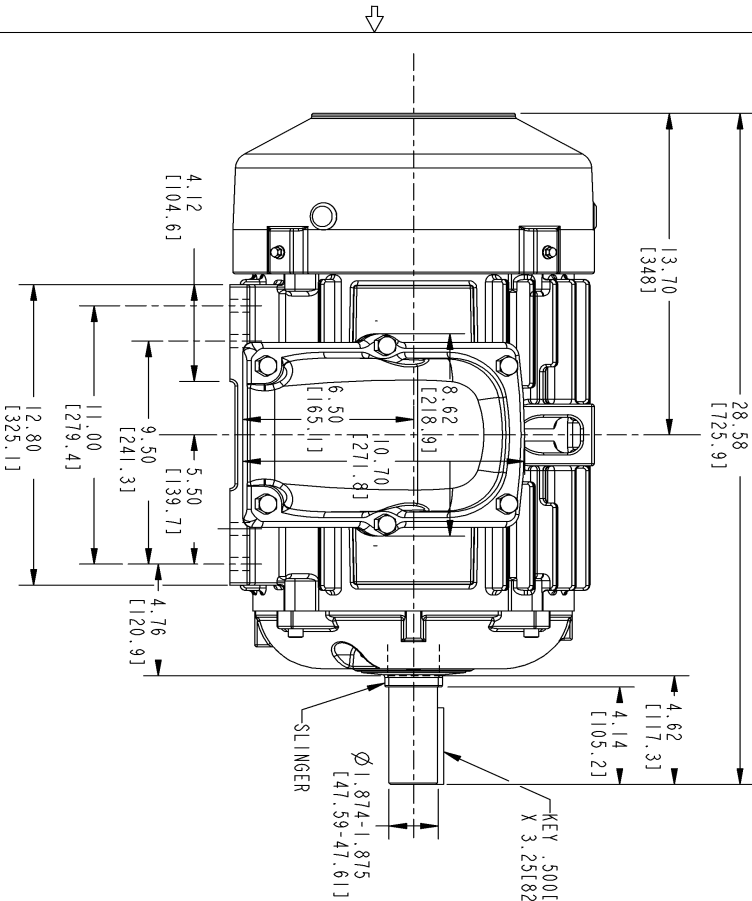

SIZE DRAWING NO. 4002B5828RAP5201

SH 2 REV

REVISIONS

REV.	DESCRIPTION	DATE	APPROVED
1	AS PER ISAC-07-1243	09/07/07	ROOPA
2	ISAC NO: #09-0164 ATUL	02/19/09	RAGHUNATH

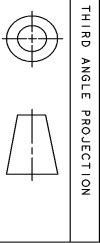

SIGNATURES	DATE	GE Industrial Systems	GENERAL ELECTRIC COMPANY
DRAWN GARY WARRNER	FEB 19/02		Fort Wayne, Indiana
CHECKED GARY WARRNER	FEB 21/02		
ENGRS			
ISSUED GARY WARRNER	APR 03/02		
APPLIED PRACTICES			
SIZE DRAWING		INDUCTION MOTOR OUTLINE	
B		STANDARD CONSTRUCTION	
SCALE: 0.225 REF. NO: 4002B5828RAP5201		FME: FR280T FCXR XSD ULTRA	
SHEET 1 OF 1		4002B5828RAP5201 REV. 2	

DISTRIBUTION: PMP-18K15

Marks:

Connection Diagram
GEM2034E-FIG7

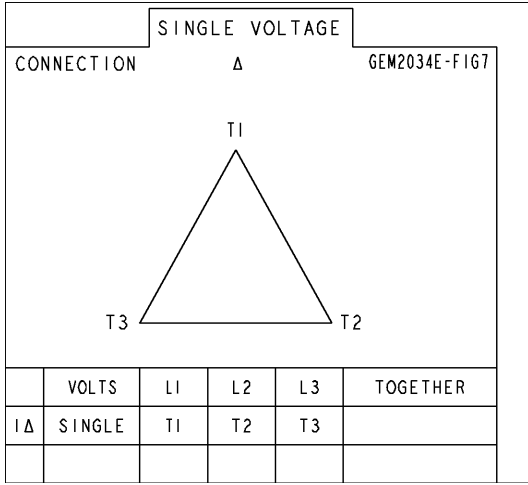

Thermostat Connection
3027JE-2A

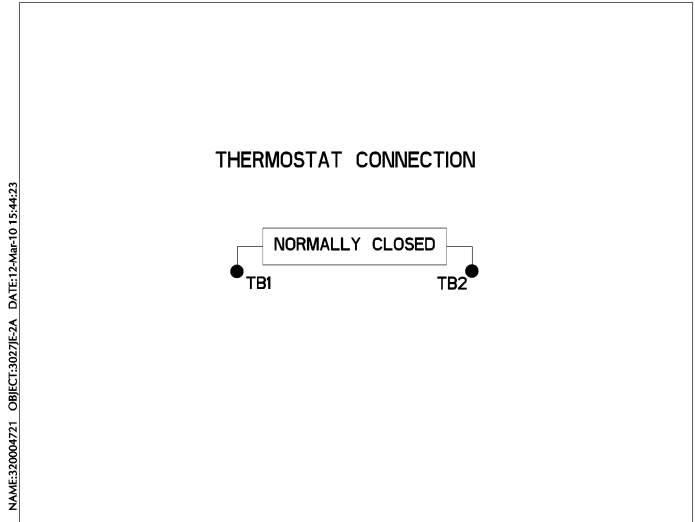

End shield Assembly		
Part Description	DE Side Part#	ODE Side Part#
End Shield	4004D5274PA1	4004D5274SA1
Bearing		
Slinger/Inproseal		

Fan & Fan Cover Assembly	
Part Description	Part#
Fan	159C6900G01
Fan Cover	

Conduit & Accessories Box Assembly	
Part Description	Part#
Conduit Box	4002B5732RA-G01

Mechanical Accessories	
Part Description	Part#
Brake	
Tachometer	

