

**Dimensional Drawing**

Catalogue	Model	HP	Pole	kW	Rating	Voltage	Hz	RPM
SDP06065	ASHH	60	6	44.76	Continuous	575 V	60	1200

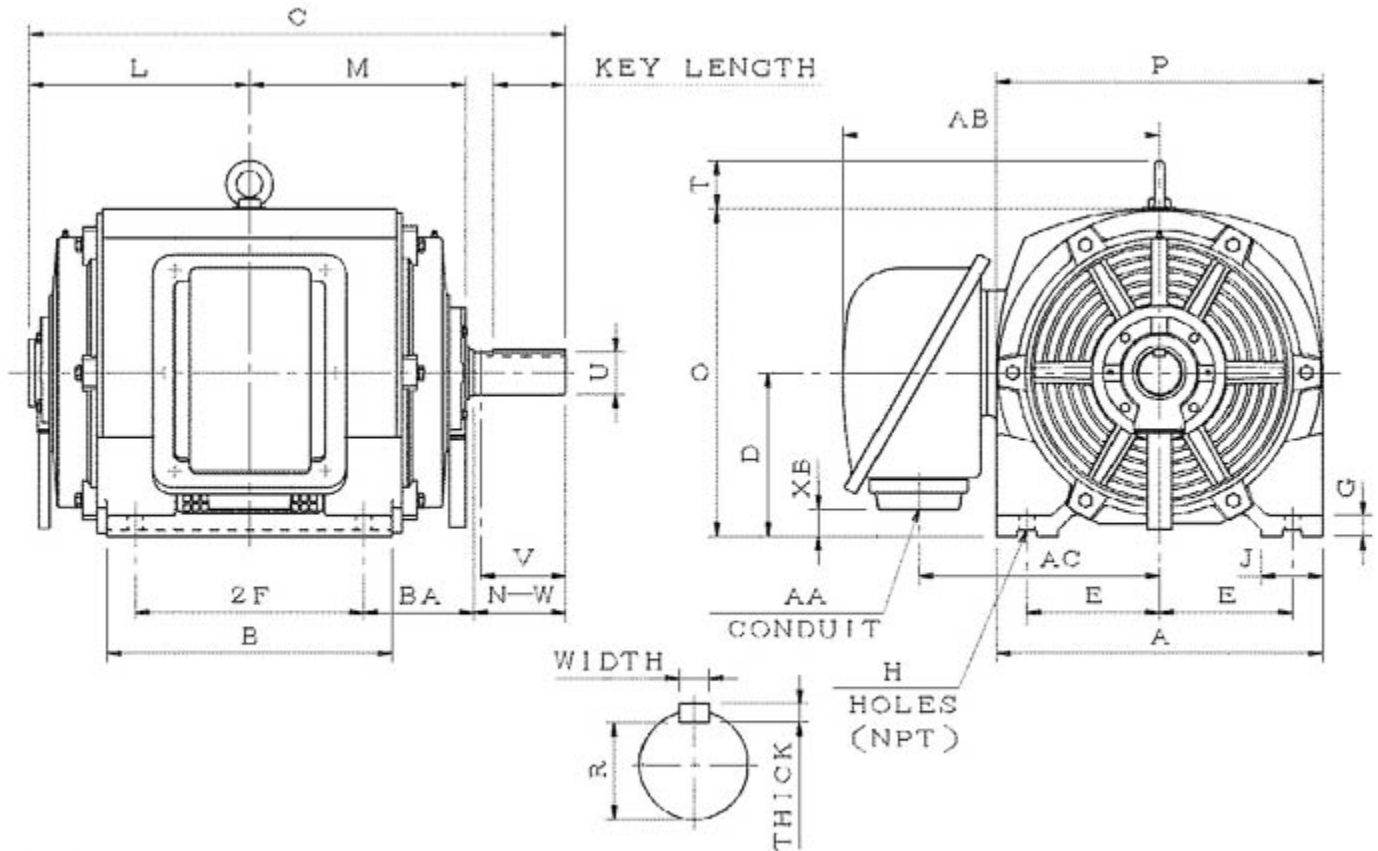

ASHH-SMP-5

Frame Size	Mounting					A	B	C	CD	D	
	E	2F	2F2	H	BA						
404T	8	12.25		0.81	6.62	19.68	15.66	32.83		10	
G	J	K	L	M	O	P	T	Key			Keyseat
1.41	3.74		12.83	12.24	19.96	19.68	3.54	Width	Thick	Length	R
								0.75	0.75	5.65	2.45
Terminal Housing				Aux Box		C/D Flange					
AA	AB	AC	XB	AE	AX	BB	AH	AK	BD	AJ	BF
3	19.4	14.76	1.81								
Shaft Extension			Bearings		Approx. Weight Lbs	SPL dBA/3ft	Ins. Class	S.F.	Drive Method	Dimensions	
N-W	U	V	DE	NDE							
7.25	2.875	7.15	6317	6317	948	68	F	1.15	Direct Coupling / Belt Drive	Inches	

### Technical Data Sheet

Motor Type: ASHH

Catalogue No: SDP06065

#### Nameplate Information

HP	Pole	RPM	Frame	Voltage	Hz	Phase
60	6	1180	404T	575	60	3
Enclosure	Ins. Class	Service Factor	Time Rating	NEMA Design	Rated Amb.	Rated Altitude
ODP	F	1.15	Continuous	C	-40 to 40 °C	<3300 ft

#### Typical Performance

Efficiency (%)				Power Factor (%)		
Full Load		3/4 Load	1/2 Load	Full Load	3/4 Load	1/2 Load
Nom.	Min.					
94.5	93.6	95.0	95.4	85.5	83.5	76.5
Torque				Current (A)		
Full Load (lb-ft)	Locked Rotor (% FLT)	Pull Up (% FLT)	Break Down (% FLT)	No Load	Full Load	Locked Rotor
266.97	200	180	225	16.2	55.6	348
NEMA KVA Code	Inertia (WR <sup>2</sup> )			Safe Stall Time (s)		Noise Level Sound Press. dB(A)
	Rotor (lb-ft <sup>2</sup> )	NEMA Load (lb-ft <sup>2</sup> )	Max. Allowable (lb-ft <sup>2</sup> )	Cold	Hot	
G	24.881	735	1248	17	12	68

#### VFD Duty Information

Speed Range			VFD		S.F.
Constant Torque	Variable Torque	Constant Power	Carrier	Type	
6-60Hz	3-60Hz	60-120Hz	≤ 5 kHz	VPWM or CPWM	1.0 Only

#### Additional Information

Bearings		Approx. Weight
DE	NDE	lbs
6317	6317	948

#### Hazardous Locations Information

N/A	
0	
0	
Temp Code (Sinewave / VFD)	0 / 0