

# Product Information Packet

November 9, 2016

Data shown is for the current revision model #. Ensure your nameplate model # matches.

<b>Model Number:</b>	<b>5KS145XAA222D2</b>
<b>Catalog Number:</b>	<b>M526</b>
<b>Instruction Manual:</b>	GEI-56128
<b>Connection Diagram:</b>	GEM2034E-FIG1
<b>Outline Drawing:</b>	4002B5814PBP5311

Accessory Connection Diagrams			
<b>Bearing Thermocouple:</b>	None	<b>Heater:</b>	None
<b>RTD:</b>	None	<b>Thermistor:</b>	None
<b>Thermostat:</b>	None	<b>Winding Thermocouple:</b>	None
<b>Bearing RTD:</b>	None		

## Table of Contents

Specification	01
Performance Characteristics	02
Outline Drawing	03
Connection Drawing(s)	04
Spare parts	05



**Marks:**

<b>MODEL NUMBER:</b>	<b>5KS145XAA222D2</b>	<b>Estimated Weight:</b>	50 Lbs
<b>Outline Drawing:</b>	4002B5814PBP5311	<b>Time Rating:</b>	CONT
<b>Connection Diagram:</b>	GEM2034E-FIG1	<b>Enclosure:</b>	TEFC
<b>Instruction Book:</b>	GEI-56128	<b>Encl Construction:</b>	841
<b>Design Code:</b>	14BD1093A	<b>Ambient Max(°C):</b>	40
<b>Type:</b>	KS	<b>Alt Ambient Max(°C):</b>	--
<b>Frame:</b>	145TC	<b>Insulation Class:</b>	H
<b>Phases:</b>	3	<b>NEMA Design:</b>	B
<b>Poles:</b>	4	<b>Nominal Efficiency:</b>	86.5 %
<b>Output Power:</b>	2HP 1.5KW	<b>Guaranteed Efficiency:</b>	85.5
<b>RPM:</b>	1735	<b>3/4 Load Efficiency:</b>	87.0
<b>Voltage:</b>	460	<b>KVA Code:</b>	L
<b>Hertz:</b>	60	<b>Max KVAR:</b>	1.0
<b>Amps - FL:</b>	2.7	<b>Power Factor:</b>	79.0
<b>Service Factor:</b>	1.15	<b>Bearing - DE:</b>	6206ZC3
<b>Alt Service Factor:</b>	--	<b>Bearing - ODE:</b>	6205ZC3

**Enclosure is Totally Enclosed Fan-Cooled**

**Stamped Nameplate Notes:**

IEEE-STD-841-2009  
 DE BRG 30BC02JP30 ODE BRG 25BC02JP30  
 MAX EXPOSED INTERNAL AND EXTERNAL SURFACE  
 TEMPERATURES UNDER USUAL SERVICE CONDITIONS  
 AT 1.00 S.F. DO NOT EXCEED 200 DEG C  
 STAMP NP249A5564P051 AS BELOW:  
 MODEL:5KS145XAA222D2 S/N: XXX  
 CSA CERTIFIED CSA09.2216219 FOR EX NA IIC 200 C GC  
 CL1 ZONE2 AEXNAIIC 200C FOR CL1DIV2 GRP ABCD 200C  
 IN -25C <= AMB <= 40C, 1.0 SF ON SINE-WAVE PWR  
 SURF TEMP 200 C AT 1.15 SF ON SINE-WAVE PWR  
 OR 200 C VT OR 200 C CT OR 200 C CHP PWM CONTROL  
 ALTERNATE RATING FOR PWM CONTROL 1.0 SF 40 C AMB  
 VT 0-60 HZ, CT 3-60 HZ, CHP 60-90 HZ

**Additional Information:**

4P - T EXTN  
 STANDARD FLOOR MOUNT  
 C/BOX 30 CU IN-0.75 NPT  
 F1 CONDUIT BOX MOUNTING  
 "C" FACE AT DE ENDSHIELD  
 PAINTED FRAME ID & SHAFT,  
 FAN COVER INSIDE & ODE E/S OUTSIDE  
 ROUTINE AND 5 POINT VIBRATION TESTS INCL IN C/BOX  
 INPRO SEAL BOTH ENDS  
 GROUND SCREW ON FRAME  
 SHAFT RUNOUT LIMIT .001" TIR

COPPER WASHER UNDER HEADS OF BEARING CAP BOLTS  
APPLY TITE-SEAL (A50CD427A) ON BEARING CAP SCREWS, RABBETS,  
AND PLUG THREADS  
OIL RESISTANT SLEEVING ON LEADS

**Performance Characteristics**

1st Winding 1st Connection

**Design: 14BD1093A**

Marks:

LOAD %	125.0	115.0	100.0	75.0	50.0	25.0	0.0
% EFF	85.07	85.68	86.62	87	85.96	79.68	0.00
% PF	83.32	81.79	80.24	71.2	58.24	37.01	7.23
AMPS	3.3	3.07	2.68	2.27	1.87	1.59	1.37

TORQ(FL)#FT	6.05	TORQ(LR)%FL	394.29	TORQ(BD)%FL	436.54
AMPS(LR)	20.52	PF AT START	0.68		

This motor is capable of two cold or one hot start with a maximum connected load inertia of 105 Lb-Ft Sq (4.42 Kg-meter Sq)at 100% voltage, where the load torque varies with the square of the speed. Acceleration time with maximum inertia and the above load type is 28 seconds. Safe stall time at 100% voltage is 59 seconds cold, 44 seconds hot. Rotor inertia is 0.12 Lb-Ft Sq (0.01 Kg-meter Sq).

Open Circuit A-C:	0.129	Short Circuit D-C:	0.005
Short Circuit A-C:	0.005	X/R Ratio:	1.753
Stator Slots:	36	Rotor Slots:	48

**Speed Torque Current Curve (First Connection, First Speed)**

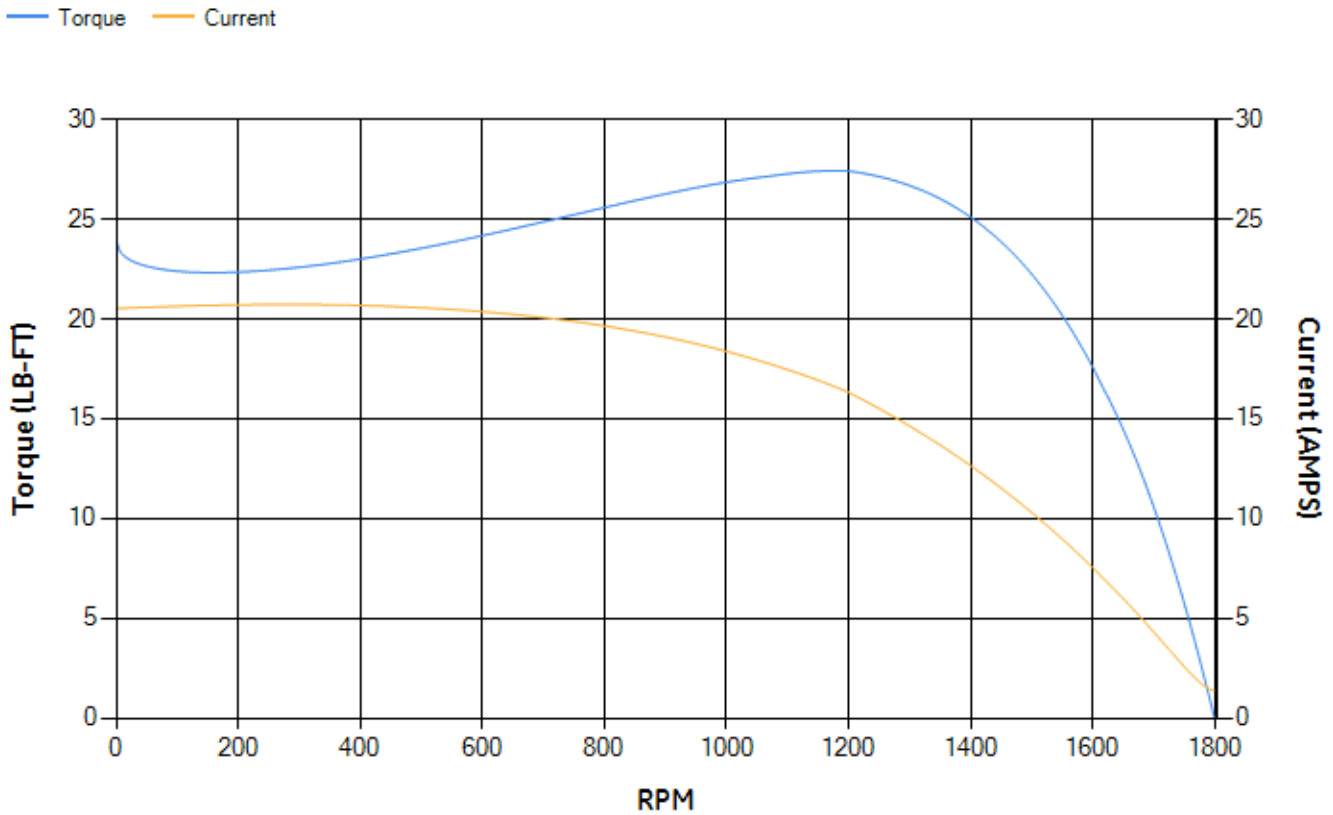

Marks:

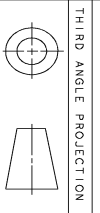
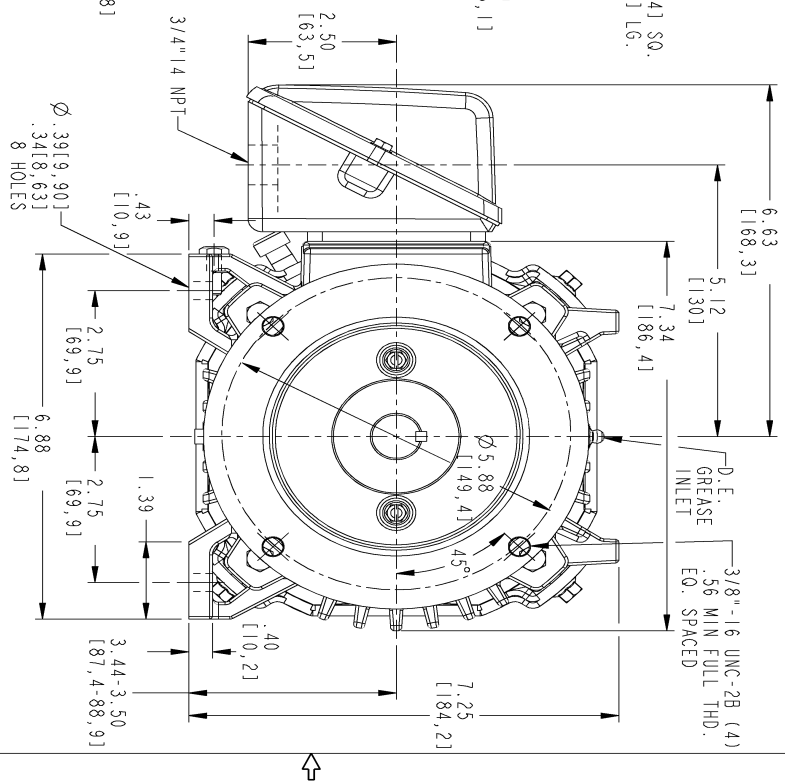
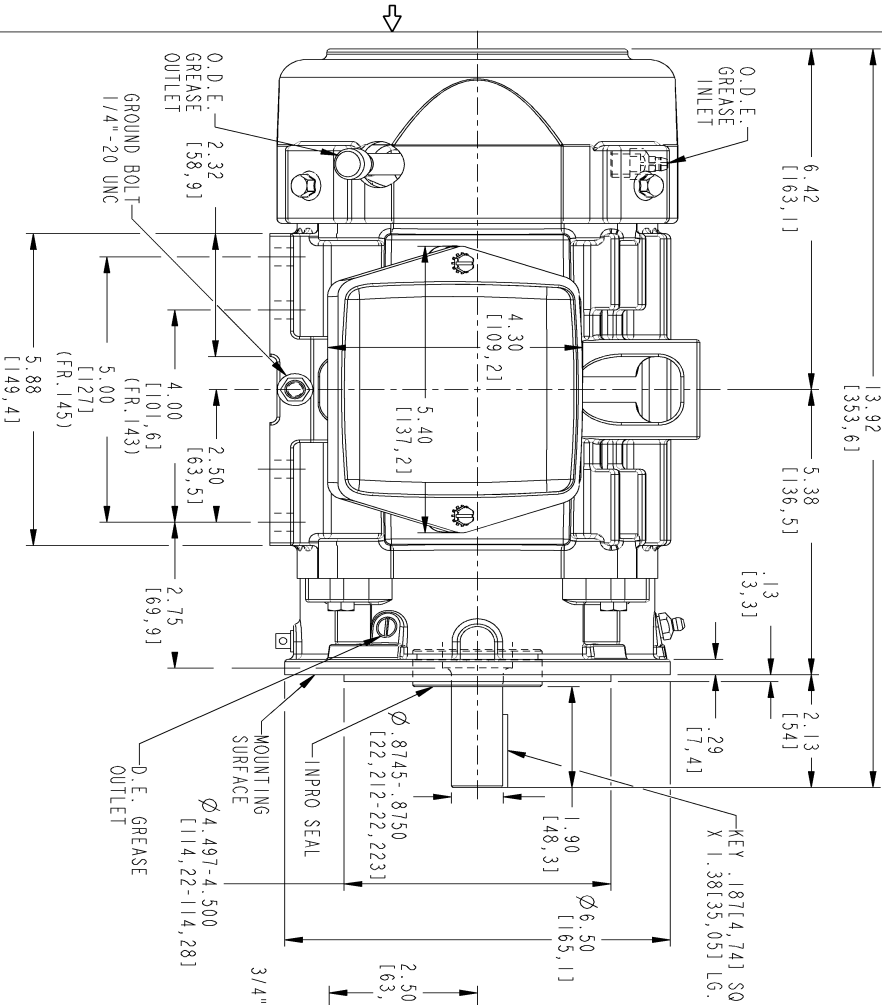

THIRD ANGLE PROJECTION

NOTE 1: CONDUIT BOX MAY BE ASSEMBLED WITH ENTRANCE UP, DOWN OR TO EITHER SIDE.  
 NOTE 2: F1 ASSEMBLY AS SHOWN. F2 ASSEMBLY CONDUIT BOX ON OPPOSITE SIDE FROM SHOWN LOCATION.  
 NOTE 3: MOUNTING SURFACES WILL BE SQUARE AND CONCENTRIC WITH SHAFT WITHIN .004 T.I.R.  
 NOTE 4: SHAFT RUNOUT WILL NOT EXCEED .001 T.I.R.  
 NOTE 5: ALL DIMENSIONS ARE IN INCHES, BRACKETED DIMENSIONS ARE IN METRIC (MILLIMETERS).

SIZE DRAWING NO. B

4002B5814PBP5311 0

REV SHEET 1

REV.	DESCRIPTION	DATE	APPROVED

REVISIONS

SIGNATURES	DATE
MODEL: TEJASNI	06/08/15
DETAIL: TEJASNI	06/08/15
DESIGN: ADI	06/08/15
ENGR: VENKAT	06/08/15
QC: TEJASNI	06/08/15
ISSUED: TEJASNI	06/08/15
SOLD TO MODEL: 4002B5814PBP5311	

**GE Motors** GENERAL ELECTRIC COMPANY

**INDUCTION MOTOR OUTLINE**  
 IEEE-841 SPEC, "C" FACE AT DE (450° RABBIT)  
 FR: 143/45TC TFC

SIZE DRAWING: 4002B5814PBP5311  
 SCALE: 0.500 REF. No.: 4002B5814PBP5301  
 SHEET 1 of 1

Marks:

**Connection Diagram**  
**GEM2034E-FIG1**

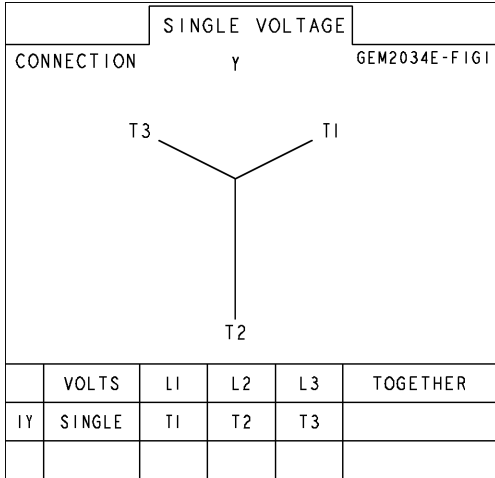

End shield Assembly		
Part Description	DE Side Part#	ODE Side Part#
End Shield	4004D5289PB1	4004D5280SG1
Bearing	235A2602AA01	235A2600AA01
Slinger/Inproseal	4002B5914AM1	4002B5914AG1

Fan & Fan Cover Assembly	
Part Description	Part#
Fan	4001A5914AM-G01
Fan Cover	4003C5785PA1

Conduit & Accessories Box Assembly	
Part Description	Part#
Conduit Box	4002B5718PA-G01

Mechanical Accessories	
Part Description	Part#
Brake	
Tachometer	

