

# Product Information Packet

January 12, 2017

Data shown is for the current revision model #. Ensure your nameplate model # matches.

<b>Model Number:</b>	<b>5KS513SAA180A</b>
<b>Catalog Number:</b>	<b>Q570</b>
<b>Instruction Manual:</b>	GEI-56128
<b>Connection Diagram:</b>	GEM2034E-FIG2
<b>Outline Drawing:</b>	239C6C00GV

Accessory Connection Diagrams			
<b>Bearing Thermocouple:</b>	None	<b>Heater:</b>	3027JE-1C
<b>RTD:</b>	235A3027XY	<b>Thermistor:</b>	None
<b>Thermostat:</b>	None	<b>Winding Thermocouple:</b>	None
<b>Bearing RTD:</b>	235A3027NA		

Table of Contents	
Specification	01
Performance Characteristics	02
Outline Drawing	03
Connection Drawing(s)	04



**Marks:**

<b>MODEL NUMBER:</b>	<b>5KS513SAA180A</b>	<b>Estimated Weight:</b>	6917 Lbs
<b>Outline Drawing:</b>	239C6C00GV	<b>Time Rating:</b>	CONT
<b>Connection Diagram:</b>	GEM2034E-FIG2	<b>Enclosure:</b>	TEFC
<b>Instruction Book:</b>	GEI-56128	<b>Encl Construction:</b>	SD
<b>Design Code:</b>	50BD0148E	<b>Ambient Max(°C):</b>	40
<b>Type:</b>	KS	<b>Alt Ambient Max(°C):</b>	--
<b>Frame:</b>	5013ST	<b>Insulation Class:</b>	F
<b>Phases:</b>	3	<b>NEMA Design:</b>	--
<b>Poles:</b>	2	<b>Nominal Efficiency:</b>	95.8 %
<b>Output Power:</b>	800HP 592KW	<b>Guaranteed Efficiency:</b>	95.0
<b>RPM:</b>	3570	<b>3/4 Load Efficiency:</b>	96.6
<b>Voltage:</b>	2300/4000	<b>KVA Code:</b>	H
<b>Hertz:</b>	60	<b>Max KVAR:</b>	102.4
<b>Amps - FL:</b>	165.4/95.1	<b>Power Factor:</b>	94.5
<b>Service Factor:</b>	1.00	<b>Bearing - DE:</b>	6315ZC3
<b>Alt Service Factor:</b>	--	<b>Bearing - ODE:</b>	6315ZC3

**Enclosure is Totally Enclosed Fan-Cooled**

**Stamped Nameplate Notes:**

HTR LDS HE1-HE2 115V 350W  
 ROT CCW FACING ODE LEAD/PH SEQUENCE 3-2-1/1-2-3  
 FOR DIRECT COUPLED LOAD ONLY

**Additional Information:**

2P - ST EXTN  
 2500 CU IN - 2(4.00" NPT)  
 100 OHM WINDING RTD LEADS TO AUX C/BOX OPP MAIN C/BOX  
 SUGGESTED WINDING RTD SETTINGS  
 ALARM 155C TRIP 165C  
 115V HTR LDS TO AUX BOX OPP MAIN CONDUIT BOX  
 SPACE HEATER CAUTION NAMEPLATE  
 BEARING RTD 100 OHM ON BOTH ENDS  
 SUGGESTED BEARING RTD SETTINGS  
 ALARM 115C TRIP 125C  
 NEMA TYPE GRD PAD  
 F1 MOUNTING

**Performance Characteristics**

1st Winding 1st Connection

**Design: 50BD0148E**

**Marks:**

LOAD %	125.0	115.0	100.0	75.0	50.0	25.0	0.0
% EFF	95.9	96.09	96.54	96.6	96.5	95.01	0.00
% PF	94.53	94.61	94.57	93.82	90.99	78.87	5.52
AMPS	118.72	108.92	94.18	71.25	49.04	28.73	16.43

<b>TORQ(FL)#FT</b>	1176.39	<b>TORQ(LR)%FL</b>	130.49	<b>TORQ(BD)%FL</b>	351.67
<b>AMPS(LR)</b>	791.43	<b>PF AT START</b>	0.18		

This motor is capable of two cold or one hot start with a maximum connected load inertia of 1116 Lb-Ft Sq (46.98 Kg-meter Sq)at 100% voltage, where the load torque varies with the square of the speed. Acceleration time with maximum inertia and the above load type is 12 seconds. Safe stall time at 100% voltage is 33 seconds cold, 14 seconds hot. Rotor inertia is 158.26 Lb-Ft Sq (6.66 Kg-meter Sq).

<b>Open Circuit A-C:</b>	1.857	<b>Short Circuit D-C:</b>	0.034
<b>Short Circuit A-C:</b>	0.041	<b>X/R Ratio:</b>	12.892
<b>Stator Slots:</b>	48	<b>Rotor Slots:</b>	40

**Speed Torque Current Curve (First Connection, First Speed)**

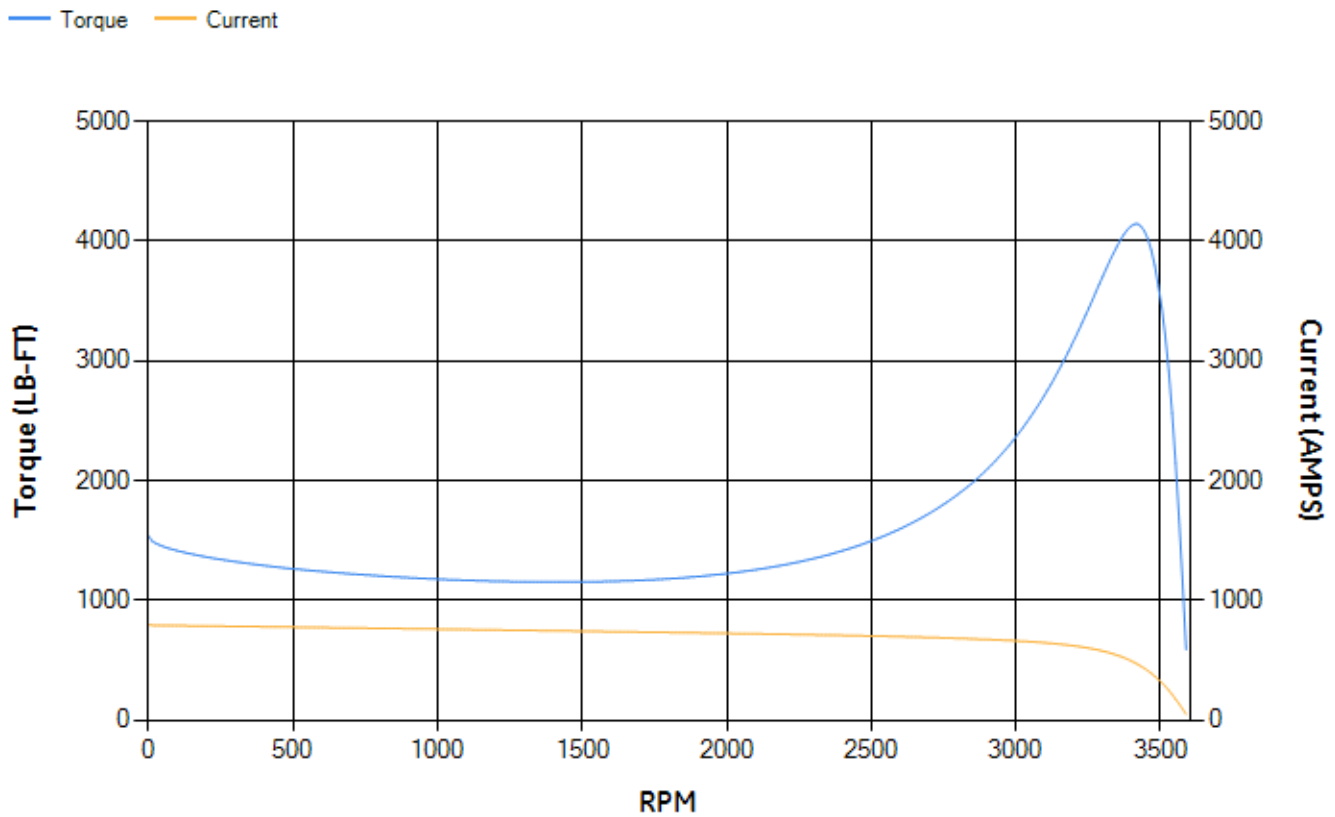



Marks:

**Connection Diagram**  
**GEM2034E-FIG2**

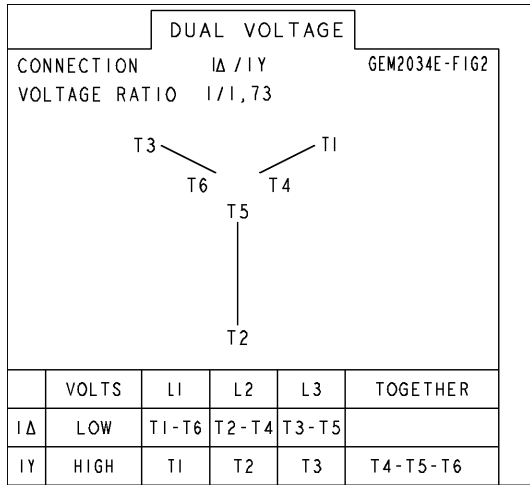

**Heater Connection**  
**3027JE-1C**



GE PROPRIETARY INFORMATION

This document is the property of General Electric Company ("GE") and contains proprietary information of GE. This document is loaned on the express condition that neither it nor the information contained herein shall be disclosed to others without the express written consent of GE Industrial Systems, and that the information shall be used by the recipient only as approved expressly by GE Industrial Systems. This document shall be returned to GE upon its request. This document may be subject to certain restrictions under U.S. export control laws and regulations.

THIRD ANGLE PROJECTION

REVISIONS				
REV.	DESCRIPTION	DATE	APPROVED	
1	ISAAC# 15-0790 HARIKIRAN	07/28/15	DHEERAJ	
2	ISAAC# 16-0422 SAGAR K	05/04/2016	ADINARAYANA	

REV SHEET 2

SIZE DRAWING NO. A

235A3027XY

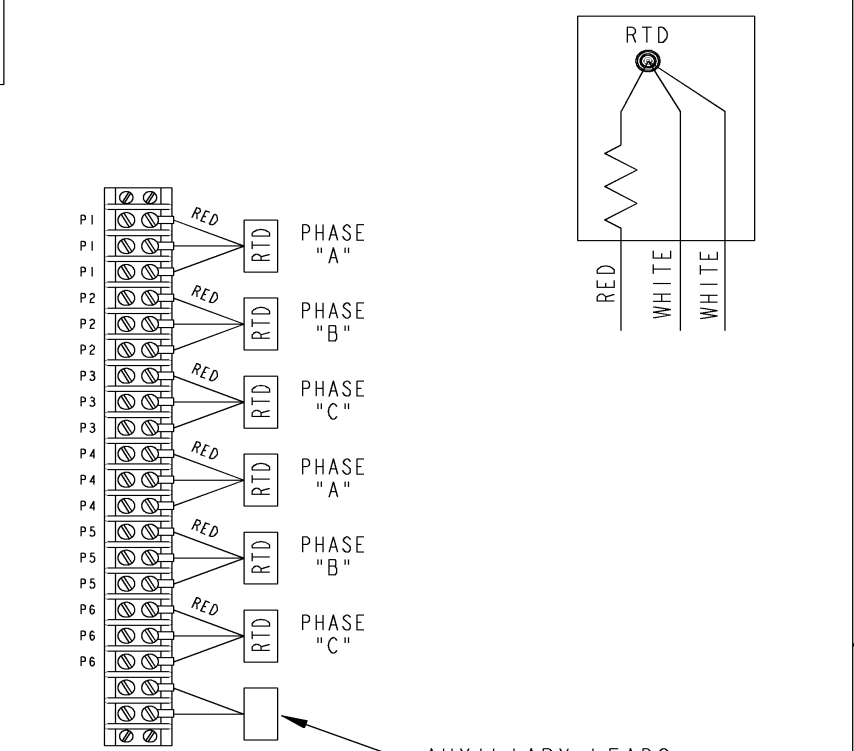

NOTE 1: AUXILIARY LEADS SHOWN MAY OR MAY NOT BE PROVIDED IN MOTOR.  
 NOTE 2: SPARE RTDS (P7 & P8) FURNISHED IN CASE OF FAILURE IN OTHER RTDS (P1-P6). PHASE LOCATION WILL DEPEND UPON NUMBER OF POLES WINDING CONFIGURATION.

Part must conform to SI 900000 Sect. 4, Toxicity Procedure

FOR ADDITIONAL INFO REFER TO:	SIGNATURES	DATE
APPLIED PRACTICES	MODEL	
DIMENSIONS ARE IN INCHES	DETAIL VIVEK	06/26/15
TOLERANCE ON:	CHECKED KARTHIK	06/26/15
1 PL DECIMALS ± 0.1	ENGRG	
2 PL DECIMALS ± 0.02	MFG	
3 PL DECIMALS ± 0.005	QUALITY	
ANGLES ± 0.5	ISSUED VIVEK	06/26/15
FRACTIONS ±		
FINISH ✓	SOLID MODEL: MODEL NAME	

**GE Motors** GENERAL ELECTRIC COMPANY

TITLE **CONNECTION DIAGRAM**  
**WINDING RTD & AUXILIARY LEADS**

SIZE DRAWING **A** **235A3027XY** REV **2**

SCALE: N.T.S. REF: - 235A4594X SHEET 1 of 1



REV SH	THIRD ANGLE PROJECTION	REVISIONS			
		REV	DESCRIPTION	DATE	APPROVED
		1	ISAAC #12-1124	HARI	11/19/12

SIZE A  
 DWG NO 235A3027NA

**CONFIDENTIAL AND PROPRIETARY**

This document is the property of General Electric Company and contains proprietary and confidential information of the Motor Business Group (MBG). The document is loaned on the express conditions that neither it nor the information contained therein shall be disclosed to others without the express consent of MBG and that the information shall be used by the recipient only as approved expressly by MBG. Also, the document shall be returned to MBG upon its request.

# BEARING RTDS

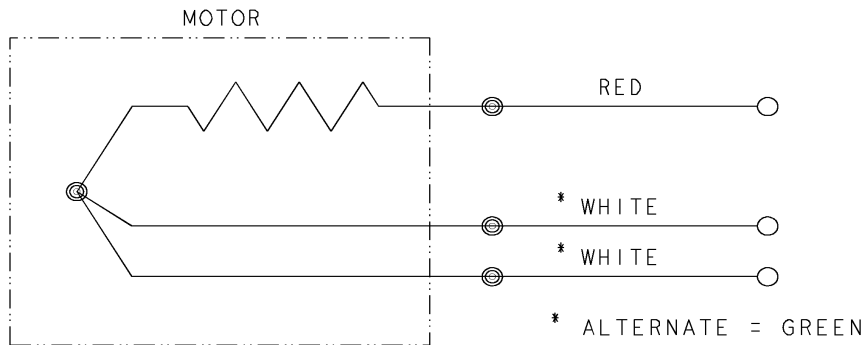

UNLESS OTHERWISE SPECIFIED DIMENSIONS ARE IN INCHES TOLERANCES ON: 2 PL DECIMALS ± 3 PL DECIMALS ± ANGLES ± FRACTIONS ± MATERIAL: APPLIED PRACTICES:	SIGNATURES	DATE	Fort Wayne, Indiana <h2>CONNECTION DIAGRAM</h2> BEARING RTDS
	DRAWN D.E. BAIR	12/16/92	
	CHECKED D.E. BAIR	12/16/92	
	ENGRG K. DESAI	12/16/92	
	ISSUED D.E. BAIR	12/16/92	
	CAD NO. F500:235A3027NA	SIZE A	FSCM NO
		SCALE 1/1	DWG NO 235A3027NA
			SHEET 1 OF 1

DISTR TO

