

Product Information Packet

November 9, 2016

Data shown is for the current revision model #. Ensure your nameplate model # matches.

Model Number:	5KS143SAA202D1
Catalog Number:	M497
Instruction Manual:	GEI-56128
Connection Diagram:	GEM2034E-FIG3
Outline Drawing:	4002B5814PBP5316

Accessory Connection Diagrams			
Bearing Thermocouple:	None	Heater:	None
RTD:	None	Thermistor:	None
Thermostat:	None	Winding Thermocouple:	None
Bearing RTD:	None		

Table of Contents

Specification	01
Performance Characteristics	02
Outline Drawing	03
Connection Drawing(s)	04
Spare parts	05



Marks:

MODEL NUMBER:	5KS143SAA202D1	Estimated Weight:	43 Lbs
Outline Drawing:	4002B5814PBP5316	Time Rating:	CONT
Connection Diagram:	GEM2034E-FIG3	Enclosure:	TEFC
Instruction Book:	GEI-56128	Encl Construction:	X\$D
Design Code:	14BD1092A	Ambient Max(°C):	40
Type:	KS	Alt Ambient Max(°C):	65
Frame:	143TC	Insulation Class:	H
Phases:	3	NEMA Design:	B
Poles:	4	Nominal Efficiency:	85.5 %
Output Power:	1HP 0.7KW	Guaranteed Efficiency:	84.0
RPM:	1755	3/4 Load Efficiency:	85.0
Voltage:	230/460	KVA Code:	N
Hertz:	60	Max KVAR:	0.7
Amps - FL:	3.2/1.6	Power Factor:	70.5
Service Factor:	1.25	Bearing - DE:	6206ZC3
Alt Service Factor:	1.00	Bearing - ODE:	6205ZC3

Enclosure is Totally Enclosed Fan-Cooled

Stamped Nameplate Notes:

SF AMPS 3.6/1.8
 STAMP NP249A5564P051 AS BELOW:
 MODEL:5KS143SAA202D1 S/N: XXX
 CSA CERTIFIED CSA09.2216219 FOR EX NA IIC 200C GC
 CL 1 ZONE2 AEX NA IIC 200C;CL 1 DIV2 GRP ABCD 200C
 IN -25C <= AMB <= 40C, 1.0 SF ON SINE-WAVE PWR
 SURF TEMP 200C AT 1.25SF ON SINE-WAVE PWR
 OR 200 C VT OR 200 C CT OR 200 C CHP PWM CONTROL
 ALTERNATE RATING FOR PWM CONTROL 1.0SF 40C AMB
 VT 0-60 HZ, CT 3-60 HZ , CHP 60-90 HZ.

Additional Information:

4P - T EXTN
 STANDARD FLOOR MOUNT
 C/BOX 30 CU IN-0.75 NPT
 F1 CONDUIT BOX MOUNTING
 "C" FACE AT DE ENDSHIELD
 INPRO SEAL DE ONLY
 OIL RESISTANT SLEEVING ON LEADS

Performance Characteristics

1st Winding 1st Connection

Design: 14BD1092A

Marks:

LOAD %	125.0	115.0	100.0	75.0	50.0	25.0	0.0
% EFF	85.49	85.66	85.91	84.95	82.07	72.52	0.00
% PF	76.84	74.68	72.44	61.7	48.54	30.42	8.27
AMPS	1.78	1.68	1.5	1.34	1.17	1.06	0.94

TORQ(FL)#FT	3	TORQ(LR)%FL	471.84	TORQ(BD)%FL	541.14
AMPS(LR)	12.69	PF AT START	0.68		

This motor is capable of two cold or one hot start with a maximum connected load inertia of 84 Lb-Ft Sq (3.54 Kg-meter Sq)at 100% voltage, where the load torque varies with the square of the speed. Acceleration time with maximum inertia and the above load type is 37 seconds. Safe stall time at 100% voltage is 82 seconds cold, 66 seconds hot. Rotor inertia is 0.08 Lb-Ft Sq (0 Kg-meter Sq).

Open Circuit A-C:	0.13	Short Circuit D-C:	0.005
Short Circuit A-C:	0.006	X/R Ratio:	1.758
Stator Slots:	36	Rotor Slots:	48

Speed Torque Current Curve (First Connection, First Speed)

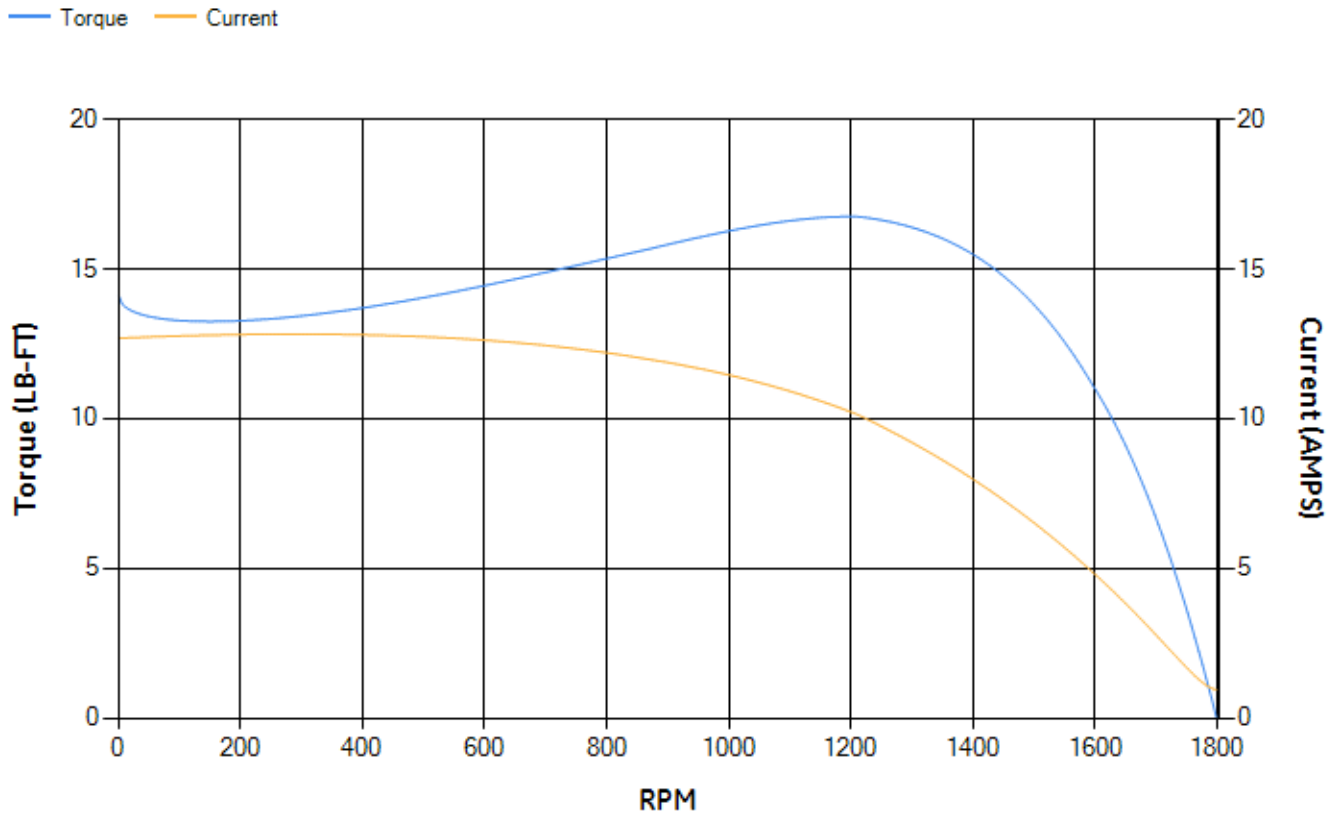

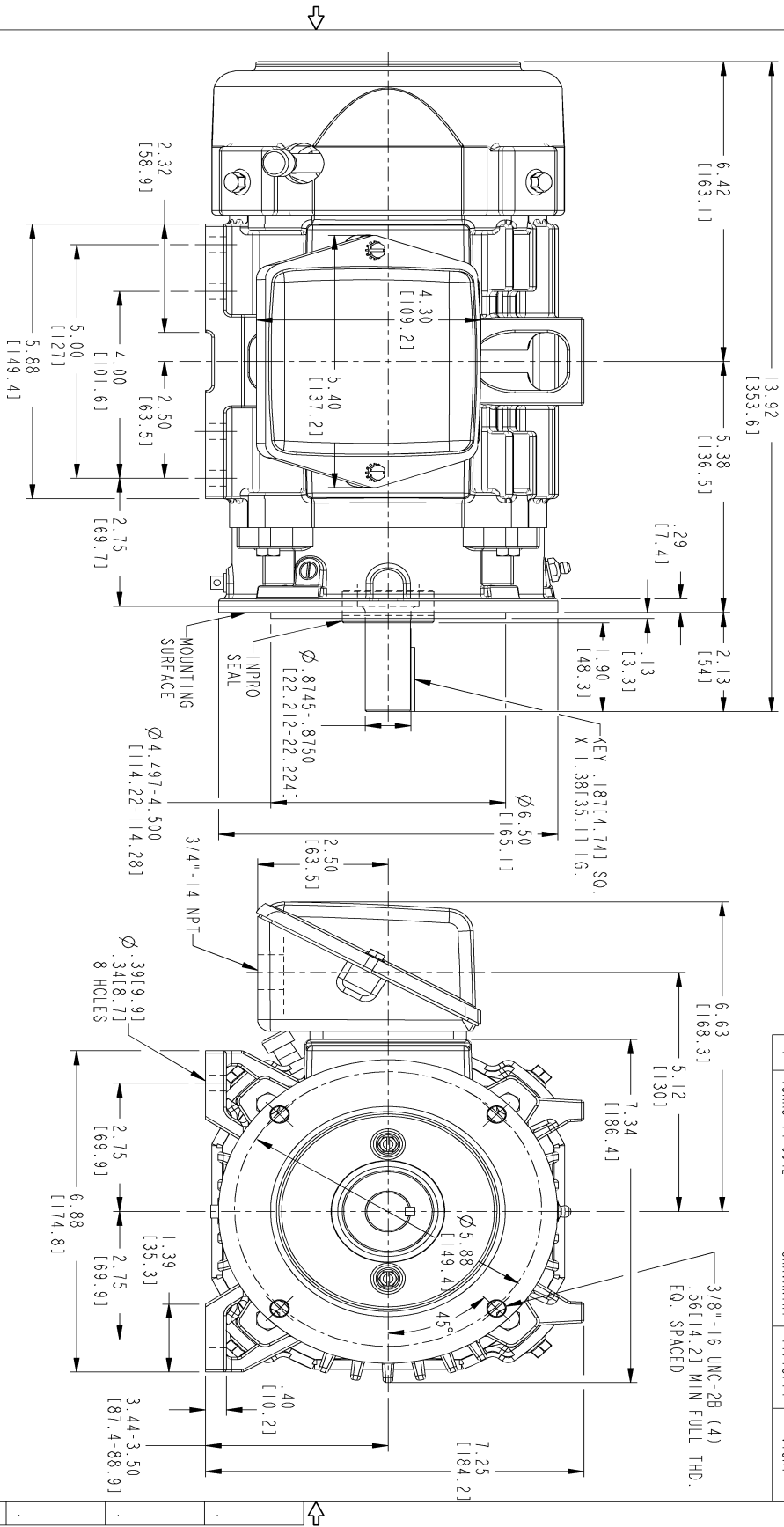

SIZE B DRAWING NO. **4002B5814PBP5316** SH 1 REV 1

REVISIONS			
REV.	DESCRIPTION	DATE	APPROVED
1	ISAAC 14-0942	SRAVANTHI 11/18/14	VJ JAY

THIRD ANGLE PROJECTION

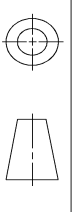

- NOTE 1: CONDUIT BOX MAY BE ASSEMBLED WITH ENTRANCE UP, DOWN OR TO EITHER SIDE.
- NOTE 2: F1 ASSEMBLY AS SHOWN. F2 ASSEMBLY CONDUIT BOX ON OPPOSITE SIDE FROM SHOWN LOCATION.
- NOTE 3: MOUNTING SURFACES WILL BE SQUARE AND CONCENTRIC WITH SHAFT WITHIN .004 T.I.R.
- NOTE 4: SHAFT RUNOUT WILL NOT EXCEED .002 T.I.R.

SIGNATURES	DATE
DESIGNED BY: SMITHIN 08/13/07	
DRAWN BY: DIXMARK 08/13/07	
ENGR BY:	
ISSUED BY: SMITHIN 08/13/07	
APPLIED PRACTICES	

GE Industrial Systems **GENERAL ELECTRIC COMPANY**
Fort Wayne, Indiana

INDUCTION MOTOR OUTLINE
C-FACE AT DRIVE END (45° RABBIT WITH INPROSEAL)
FWE: FR140TC TFC XSD ULTRA

SIZE DRAWING: **4002B5814PBP5316** REV. 1
SCALE: 0.500 REF. NO.: 4002B5814PBP5201 SHEET 1 OF 1

DISTRIBUTION: PMP-18K15

Marks:

Connection Diagram
GEM2034E-FIG3

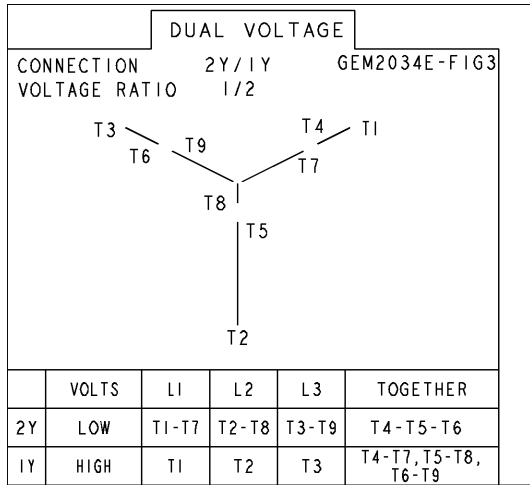

End shield Assembly		
Part Description	DE Side Part#	ODE Side Part#
End Shield	4004D5289PB1	4004D5280SG1
Bearing	235A2602AA01	235A2600AA01
Slinger/Inproseal	4002B5914AM1	149C4399G15

Fan & Fan Cover Assembly	
Part Description	Part#
Fan	4001A5914AM-G01
Fan Cover	4003C5785PA1

Conduit & Accessories Box Assembly	
Part Description	Part#
Conduit Box	4002B5718PA-G01

Mechanical Accessories	
Part Description	Part#
Brake	
Tachometer	