

Product Information Packet

November 8, 2016

Data shown is for the current revision model #. Ensure your nameplate model # matches.

Model Number:	5KS326XAA155D5
Catalog Number:	M8973
Instruction Manual:	GEI-56128
Connection Diagram:	GEM2034E-FIG7
Outline Drawing:	239C6001FS

Accessory Connection Diagrams			
Bearing Thermocouple:	None	Heater:	None
RTD:	None	Thermistor:	None
Thermostat:	None	Winding Thermocouple:	None
Bearing RTD:	None		

Table of Contents

Specification	01
Performance Characteristics	02
Outline Drawing	03
Connection Drawing(s)	04
Spare parts	05



Marks:

MODEL NUMBER:	5KS326XAA155D5	Estimated Weight:	690 Lbs
Outline Drawing:	239C6001FS	Time Rating:	CONT
Connection Diagram:	GEM2034E-FIG7	Enclosure:	TEFC
Instruction Book:	GEI-56128	Encl Construction:	841
Design Code:	32BD0154A	Ambient Max(°C):	40
Type:	KS	Alt Ambient Max(°C):	--
Frame:	326TSC	Insulation Class:	H
Phases:	3	NEMA Design:	B
Poles:	2	Nominal Efficiency:	93.0 %
Output Power:	50HP 37KW	Guaranteed Efficiency:	92.4
RPM:	3565	3/4 Load Efficiency:	94.1
Voltage:	460	KVA Code:	G
Hertz:	60	Max KVAR:	14.3
Amps - FL:	57.8	Power Factor:	87.0
Service Factor:	1.15	Bearing - DE:	6312ZC3
Alt Service Factor:	--	Bearing - ODE:	6312ZC3

Enclosure is Totally Enclosed Fan-Cooled

Stamped Nameplate Notes:

IEEE-STD-841-2009
 DE BRG 60BC03JP30, ODE BRG 60BC03JP30
 STAMP NP249A5564P051 AS BELOW:
 MODEL:5KS326XAA155D5 S/N: XXX
 CSA CERTIFIED CSA09.2216219 FOR EX NA IIC 200 C GC
 CL 1 ZONE2 AEX NA IIC 200C;CL 1 DIV2 GRP ABCD 200C
 IN -25C <= AMB <= 40C, 1.0 SF ON SINE-WAVE PWR
 SURF TEMP 230C AT 1.15SF ON SINE-WAVE PWR
 OR 200 C VT OR 230 C CT OR 200 C CHP PWM CONTROL
 ALTERNATE RATING FOR PWM CONTROL 1.0SF 40C AMB
 VT 0-60 HZ, CT 10-60 HZ, CHP 60-75 HZ.

Additional Information:

2P - TS EXTN
 PAINTED FRAME ID & SHAFT,
 FAN COVER INSIDE & ODE E/S OUTSIDE
 C FACE ON DE
 346 CU IN - 3.00" NPT
 INPRO SEAL BOTH ENDS
 OIL RESISTANT SLEEVING ON LEADS
 .0015" TIR SHAFT RUNOUT
 ROUTINE TEST REPORT AND 5 POINT VIBRATION TEST
 REPORT INCLUDED IN C/B
 COPPER WASHER UNDER HEADS OF BEARING CAP BOLTS,
 APPLY TITE-SEAL (A50CD427A) ON BEARING CAP SCREWS,
 RABBETS AND PLUG THREADS.
 GROUND PAD

F1 MOUNTING

TEFC XSD-841 ULTRA STOCK 06/28/2016

ENGINEERED BY: BALASUBRAMANIANH/DHEERAJB



Performance Characteristics

1st Winding 1st Connection

Design: 32BD0154A

Marks:

LOAD %	125.0	115.0	100.0	75.0	50.0	25.0	0.0
% EFF	93.51	93.73	94.17	94.07	93.36	89.8	0.00
% PF	88.45	88.05	87.03	83.47	74.97	53.41	5.72
AMPS	70.73	65.21	57.04	44.7	33.43	24.39	19.92

TORQ(FL)#FT	73.6	TORQ(LR)%FL	174.97	TORQ(BD)%FL	296.72
AMPS(LR)	375.21	PF AT START	0.31		

This motor is capable of two cold or one hot start with a maximum connected load inertia of 156 Lb-Ft Sq (6.57 Kg-meter Sq) at 100% voltage, where the load torque varies with the square of the speed. Acceleration time with maximum inertia and the above load type is 21 seconds. Safe stall time at 100% voltage is 45 seconds cold, 25 seconds hot. Rotor inertia is 4.62 Lb-Ft Sq (0.19 Kg-meter Sq).

Open Circuit A-C:	0.795	Short Circuit D-C:	0.019
Short Circuit A-C:	0.04	X/R Ratio:	7.021
Stator Slots:	48	Rotor Slots:	38

Speed Torque Current Curve (First Connection, First Speed)

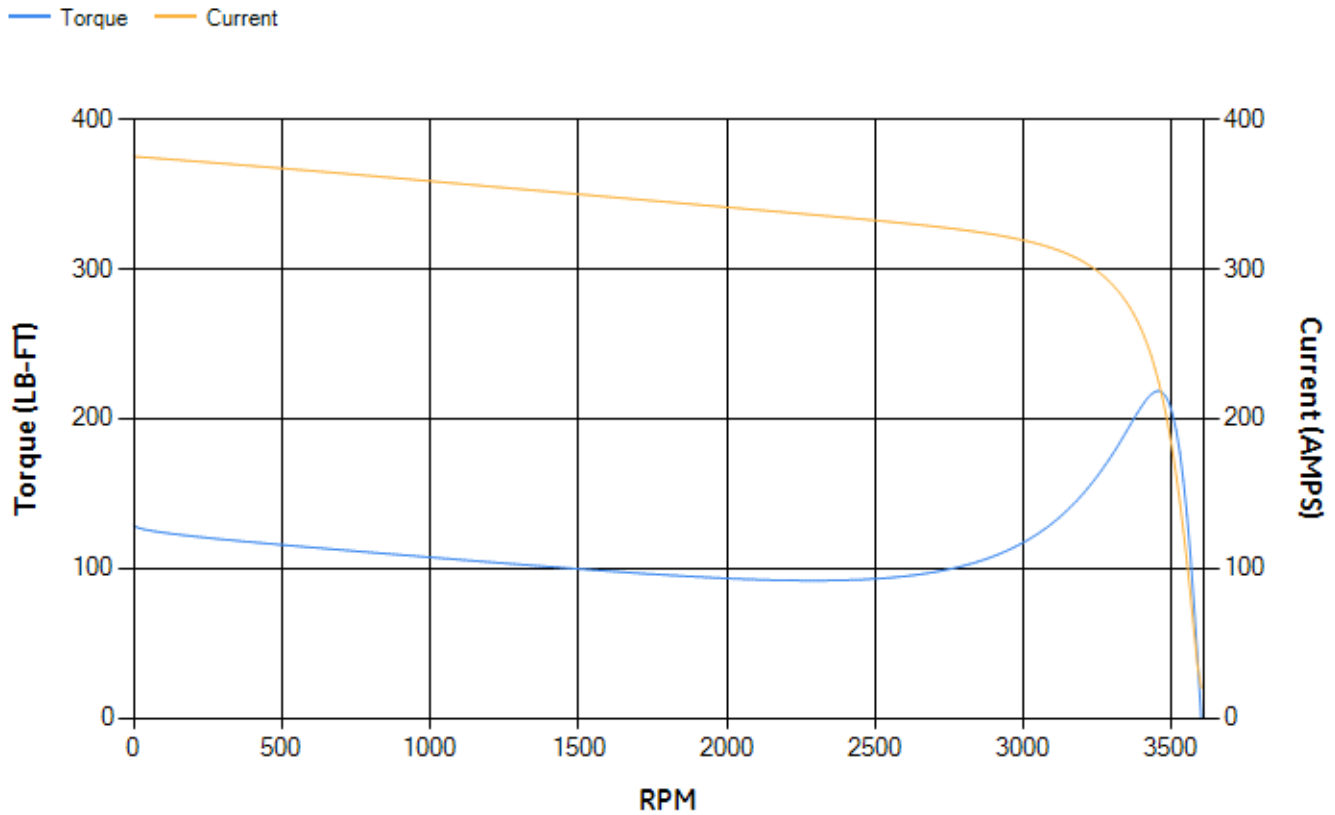

Marks:

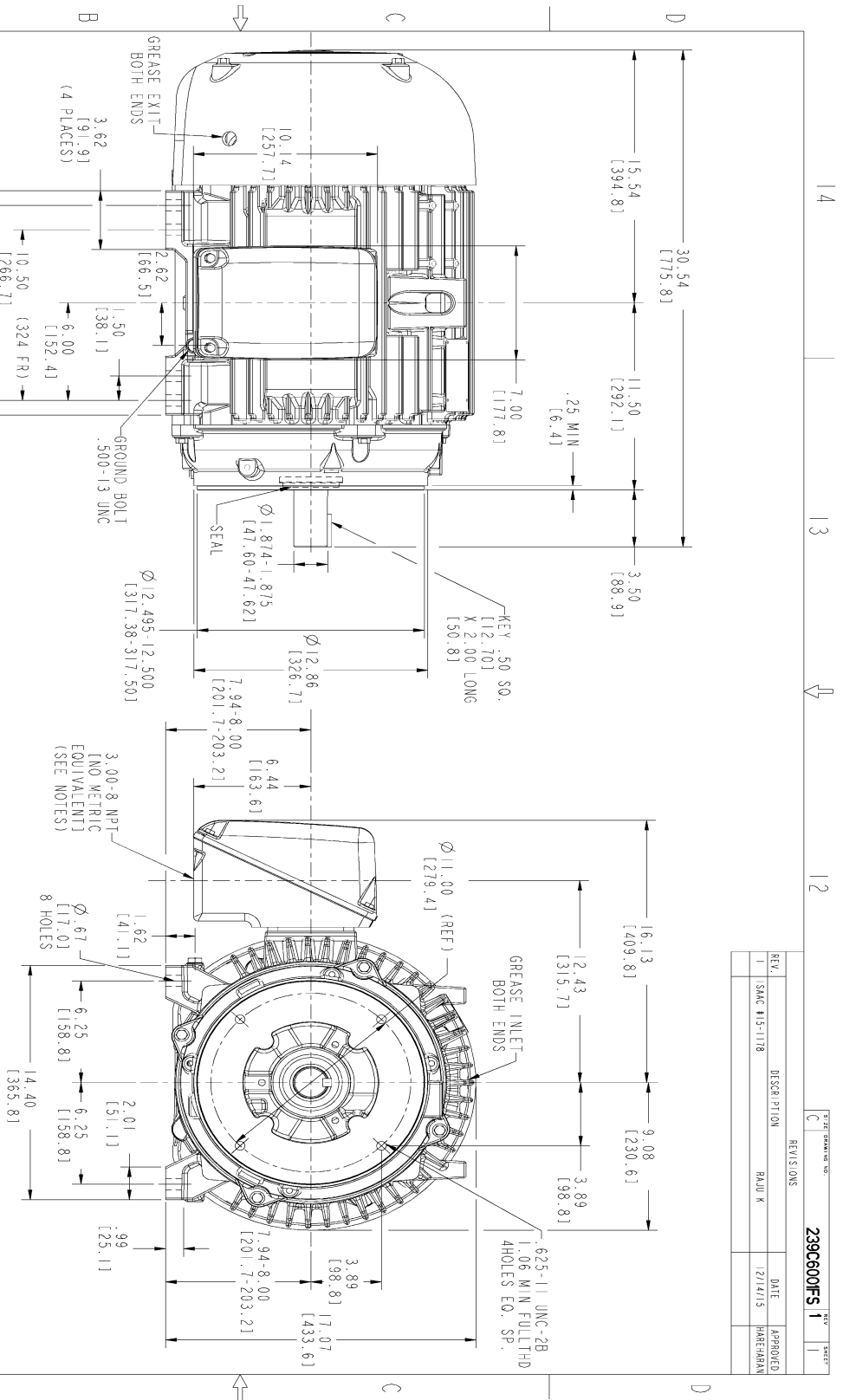

NOTES :

1. CONDUIT BOX MAY BE PLACED WITH THE ENTRANCE DOWN, UP OR ON EITHER SIDE.
2. F-1 ASM AS SHOWN.
3. F-2 ASM HAS CONDUIT BOX ON OPPOSITE SIDE.
4. BRACKETED DIMENSIONS ARE METRIC (MILLIMETERS).
5. TOLERANCE ON PERMISSIBLE SHAFT EXTENSION ROUNDOFF IS .0015 T.I.R.

REV. 1		DATE 12/14/15	
DESCRIPTION RAJUK K		APPROVED HARESHRAN	
REVISED			
239C6001FS 1			

SIGNATURES		DATE	
DESIGNER	TEJASNI	06/26/15	
CHECKED	VJANI	06/26/15	
DATE	VENKAT	06/26/15	
<p style="text-align: center;">GE Motors</p> <p style="text-align: center;">GENERAL ELECTRIC COMPANY</p> <p style="text-align: center;">OUTLINE</p> <p style="text-align: center;">324/326 TSC TFC XSD-941</p> <p style="text-align: center;">346 CU IN CONDUIT BOX</p> <p style="text-align: center;">239C6001FS</p>			
SCALE: 0.250		SHEET 1 OF 1	

Marks:

Connection Diagram
GEM2034E-FIG7



End shield Assembly		
Part Description	DE Side Part#	ODE Side Part#
End Shield	115E4203AA1	115E4200LA1
Bearing	235A2609AA01	235A2609AA01
Slinger/Inproseal	235A4575GS2	235A4575GS2

Fan & Fan Cover Assembly	
Part Description	Part#
Fan	159C6700G02
Fan Cover	128D6800AA1

Conduit & Accessories Box Assembly	
Part Description	Part#
Conduit Box	149C4429AA2

Mechanical Accessories	
Part Description	Part#
Brake	
Tachometer	