

TAP 3/8" - 16 UNC
1.12" DEEP
CLASS 3 R.H.

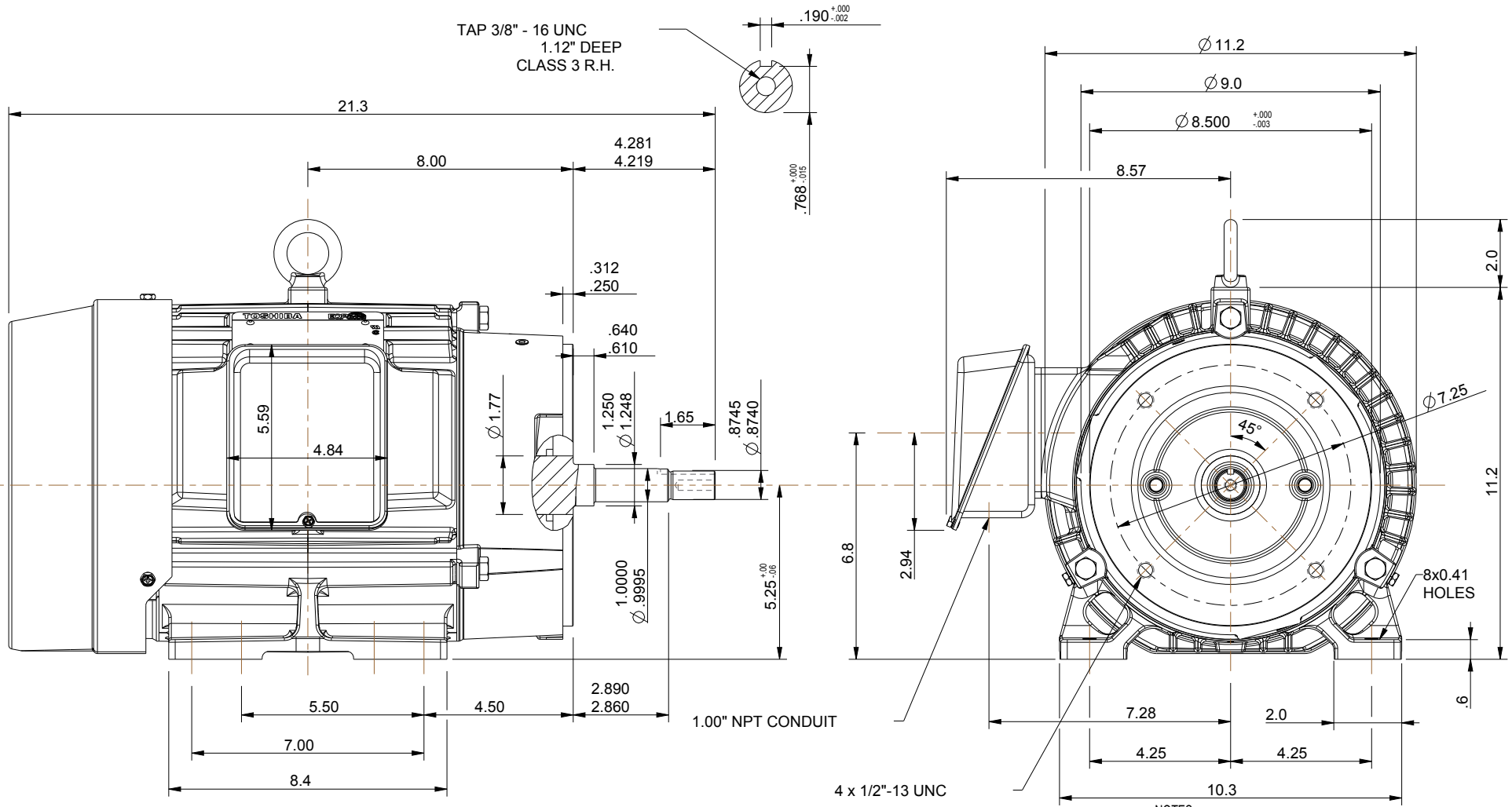

- NOTES:
 1. MAIN CONDUIT BOX MAY BE ROTATED IN 90° INCREMENTS
 2. STANDARD PRODUCT USE BI-DIRECTIONAL FAN. OPPOSITE ROTATION AVAILABLE ONLY BY CONNECTION CHANGE.
 3. KEY DIMENSIONS EQUAL (MOTOR SUPPLIED WITH KEY)
- 0.188" x 0.188" x 1.65"

UNITS: INCHES

TOSHIBA RESERVES THE RIGHT TO MAKE CHANGES OF TECHNICAL IMPROVEMENT WITHOUT NOTICE. DO NOT USE FOR CONSTRUCTION, INSTALLATION, OR APPLICATION PURPOSES UNLESS THE DRAWING IS CERTIFIED.

**210JM TEFC FRAME
F1 ASSEMBLY**

MDSL108-03

TOSHIBA

TOSHIBA INTERNATIONAL CORPORATION

TOLERANCES

.X	.1
.XX	.03
.XXX	.005
.XXXX	.0005

MAXIMUM
MOTOR WEIGHT

186 lbs.
84 kgs.

NO	REVISION	DATE	CHECK
2	CHANGED SFT. DIA. AT C-FLANGE (OVERRIDE 'R' DIM.)	MO 04/25/14	JR
1	CHANGE T-BOX ASSEMBLY	MO 12/18/13	JR
0	FIRST ISSUE	M.EASTERBROOK 5/30/13	JR
		DRAWN BY	DATE
		CHECK	



DRAWN BY: M. EASTERBROOK
 CHECK BY: J. RUSSELL
 APPROVED BY:

www.toshiba.com/ind